

## End Trucks 450 Series

These instructions are for 450 Series End Trucks, as used on TC/American Crane 450 Series Patented Track rail.

Also, see *450 Series Trolleys Installation Instructions* for the plain (idler) trolleys and *Motorized Trolleys Installation Instructions* for the motorized trolleys used on these end trucks. Also see the TC/American Crane Systems Catalog (available on the TC/American Crane website, [tcamerican.com](http://tcamerican.com)).

### DANGER

#### Lifting Operations

Installation of equipment such as TC/American Crane's End Trucks requires performance of overhead lifting operations. Proper lifting procedures involve training, skills and experience beyond the scope of this document. Workplace supervisors are responsible to assure that all persons under their supervision are properly trained, properly equipped, and are following safety practices appropriate for the lifting operation being employed.

### DANGER

#### Overhead Mechanical Assembly

Persons performing installation and assembly of overhead equipment must use caution while lifting, assembling and adjusting components. These operations are frequently conducted from manlifts or platforms that require specific knowledge, training and operation skills beyond the scope of this document.

Access to the floor below the work area must be restricted to reduce the potential of personnel injury due to falling objects.

Workplace supervisors are responsible to assure that all persons under their supervision are properly trained, properly equipped, and are following appropriate safety practices.

### DANGER

#### Electrical Equipment Installation, Service and Maintenance

Persons performing installation, service or maintenance activities on, near, or with equipment that is electrically powered are exposed to electrical hazards that could result in serious injury or death if proper precautions are not followed. Before performing such work, disconnect the electrical power source for the system at the disconnect device and lock it out, following appropriate Lockout/Tagout (LOTO) procedures, to prevent electric power from being applied while work is being performed.

All persons must use safe work practices appropriate to the electrical system, and follow all workplace procedures and policies. This requires specific knowledge, equipment and training beyond the scope of this document. Workplace supervisors are responsible to assure that all persons under their supervision are properly trained, properly equipped, and are following appropriate safety practices.

Index

<u>Item</u>	<u>Page</u>
A. General Safety Alerts .....	1
B. End Truck Model Numbers and Descriptions.....	3
C. General Installation Instructions	
D. Before Beginning Installation .....	4
E. Assembling Trolleys on End Trucks .....	4
F. Installing End Trucks on Rail .....	4
G. Initial Start-Up .....	4
H. 450 Series End Trucks	
I. 4-Wheel End Trucks	
J. 45ET-30000-4SR, 45ET-30000-4SRC .....	5
K. End Truck Frame Configuration, for use with Plain Trolleys .....	6
L. End Truck Frame Configuration, for use with Motorized Trolley .....	6
M. Restraining Lugs on 45ET-30000 .....	7
N. Procedure to Install on Rail.....	7
O. 8-Wheel End Trucks	
P. 45ET-60000-8SR, 45ET-60000-8SRC .....	8
Q. End Truck Frame Configuration, for use with Plain Trolleys .....	9
R. End Truck Frame Configuration, for use with Motorized Trolley .....	9
S. Restraining Lugs on 45ET-60000 .....	10
T. Procedure to Install on Rail.....	10
U. Drive Tire Adjustment.....	11
V. Lubrication.....	11

## End Trucks

TC/American Crane offers several models of end trucks for use on cranes or carriers. Selection of the appropriate model depends upon the size of the rail on which the end truck will operate, the load to be carried, powered travel or hand pushed, service duty class, and other factors.

### End Truck Model Numbers:

(general information for all end trucks)

- The first character(s) of the Model Number identifies the rail size on which the End Truck operates:
  - 2 = 200 Series Rail
  - 3 = 325 Series Rail
  - 4 = 400 Series Rail
  - 45 = 450 Series Rail
- The second characters, "ET," identify the product as an "End Truck."
- The intermediate numbers are the end truck capacity; i.e.:
  - 2600 = 2600 pound capacity
  - 5400 = 5400 pound capacity
  - 12400 = 12400 pound capacity
  - 16000 = 16000 pound capacity
  - etc.
- The next number, or number and letters, identify the end truck by number of wheels, trolley type and, in some cases, wheelbase:
  - 4 = 4-wheel end truck with flanged wheels (end truck has two 2-wheel trolleys)
  - 4L = 4-wheel end truck with flanged wheels and longer than standard wheelbase
  - 4SR = 4-wheel end truck with flangeless wheels and side rollers ("SR")
  - 4SRL = 4-wheel end truck with flangeless wheels, side rollers and longer wheelbase
  - 4X = 4-wheel end truck with flanged wheels and shorter than standard wheelbase
  - 8 = 8-wheel end truck with flanged wheels (end truck has two 4-wheel trolleys)
  - 8L = 8-wheel end truck with flanged wheels and longer than standard wheelbase
  - 8SR = 8-wheel end truck with flangeless wheels and side rollers ("SR")
  - 8SRL = 8-wheel end truck with flangeless wheels, side rollers and longer wheelbase
- The last character of the model number (if present) identifies the type of motorized trolley drive used on the end truck:
  - None = No motorized trolley drive used, or none available
  - A = "A" Drive
  - AT = "AT" Drive
  - B = "B" Drive
  - C = "C" Drive

Note: Many end trucks may be used with a drive tire system (either rubber or polyurethane tire pressing against the underside of the riding tread). These end trucks do not have a unique model identification. See the TC/American Crane Systems Catalog for end trucks that may be used in this application (requires adequate wheelbase length).

**NOTE: See the appropriate section(s) of these instructions for assembly, installation and maintenance details specific to your End Truck model.**

**NOTE: For a specific parts breakdown of the End Truck provided with an order, see the drawings provided with that shipment and the End Truck Section of TC/American Crane Systems Catalog.**

---

## General Installation Instructions

### Before beginning the installation:

- When shipment is received, remove all shipping materials and check all parts for damage. Repair and/or replace if necessary.
- Check packing lists against materials received and identify all parts.
- Gather all TC/American Crane drawings, other vendor equipment drawings, and associated manuals (motor, reducer, brake, electrical components, etc.) as applicable and keep in a secure location for reference during installation and start-up, and to give to end user for future reference.
- Turn trolley wheels and guide rollers by hand to check for possible damage in shipment. Check for rough bearings, loose bearings and axles.
- Check electrical collectors (if provided) for condition and proper operation. Check collector wiring for routing and security.
- Store all equipment in a clean, secure area prior to final assembly.

### Assembling Trolleys on End Trucks:

- Check crane or layout drawings for any notes about crane orientation or trolley positions.
- End trucks are normally assembled to a bridge beam rail or a hoist carrier frame, and will be handled as part of a crane or carrier assembly.
- 450 Series Trolleys are shipped loose (not mounted on the crane or carrier) because of their size and weight.
- 4-wheel crane trolley loadbars may or may not have been removed for shipping. See instructions for mounting

#### Idler (Plain) Trolleys:

- See the Index for the appropriate pages of this document for assembly instructions and illustrations for the end truck being used.
- Also see *450 Series Trolleys Installation Instructions*.

#### Motorized Trolleys:

- See the Index for the appropriate pages of this document for assembly instructions and illustrations for the end truck being used.
- Also see *Motorized Trolley Installation Instructions*. NOTE: the motor must be removed from the motorized trolley gearbox in order to provide access to install the loadbar pin.
- If the end trucks are used with a Center Motor Drive (with drive tires under the tee section), they must be 9' wheelbase, minimum, to allow space for the drive wheel assembly.

### Installing End Trucks on Rail:

- See the Installation Procedure (and Options) described on the pages for each model of end truck. See the Index for appropriate pages.
- Lift components into position on runway or monorail and re-assemble. Use extreme caution when lifting equipment into place.

### Initial Start-Up:

- Operate crane or carrier through entire length of system.
- Check clearances of trolleys to rail at rail joint bolts and suspension hardware.
- Check clearances of all portions of crane to the surrounding structures.
- Check operation through all speeds and verify conformance to specifications.

## 450 Series End Trucks

### 4-Wheel End Trucks

<b>45ET-30000-4SR</b>	6'-0" wheelbase	Figure 1
<b>45ET-30000-4SRC</b>	6'-0" wheelbase	Figure 2
<b>45ET-30000-4SR</b>	9'-0" wheelbase	Not Shown
<b>45ET-30000-4SRC</b>	9'-0" wheelbase	Not Shown

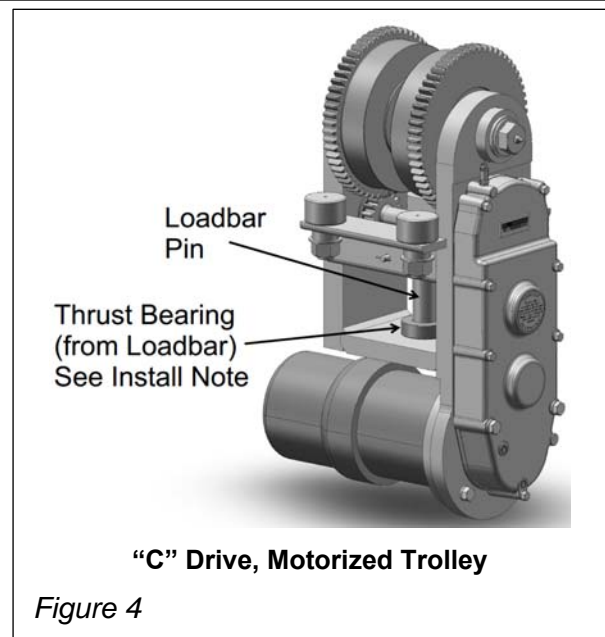
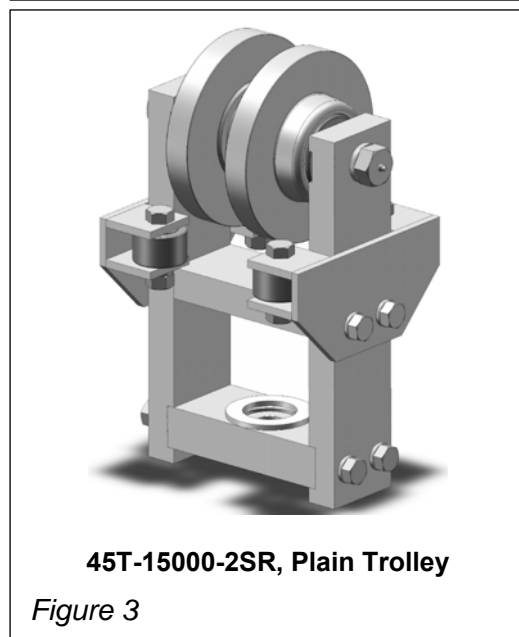
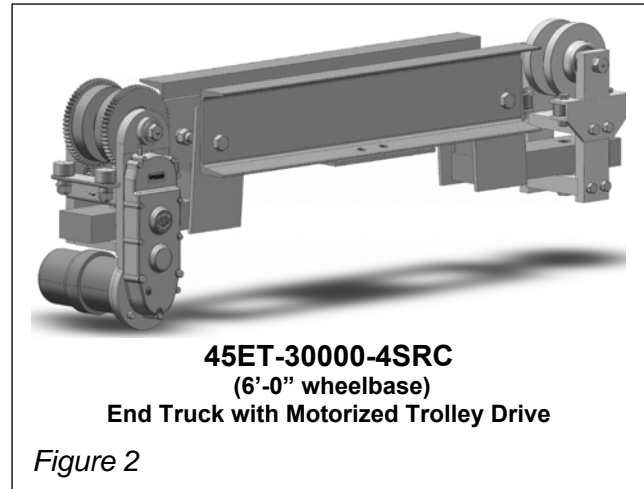
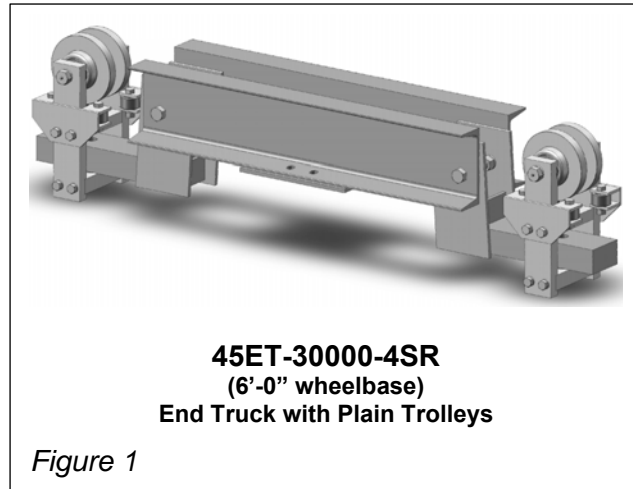

For general end truck assembly and components of 4-wheel units, see Figures 3 through 10.

- Figure 3: standard 2-wheel trolley assembly. See *450 Trolleys Installation Instructions*
- Figure 4: typical 2-wheel motorized trolley assembly. See *Motorized Trolley Installation Instructions*
- Figure 5: configuration of end truck frame for use with two plain (idler) trolleys
- Figure 6: detail of Saddle Lug under load bar
- Figure 7: detail of assembly of felt washer, thrust bearing, spherical washer and retaining screw (components provided with plain trolley assembly)
- Figure 8: configuration of end truck frame for use with one plain (idler) trolley and motorized trolley
- Figure 9: detail of loadbar machining for use with motorized trolley
- Figure 10: detail of assembly of loadbar pin and thrust bearing into loadbar

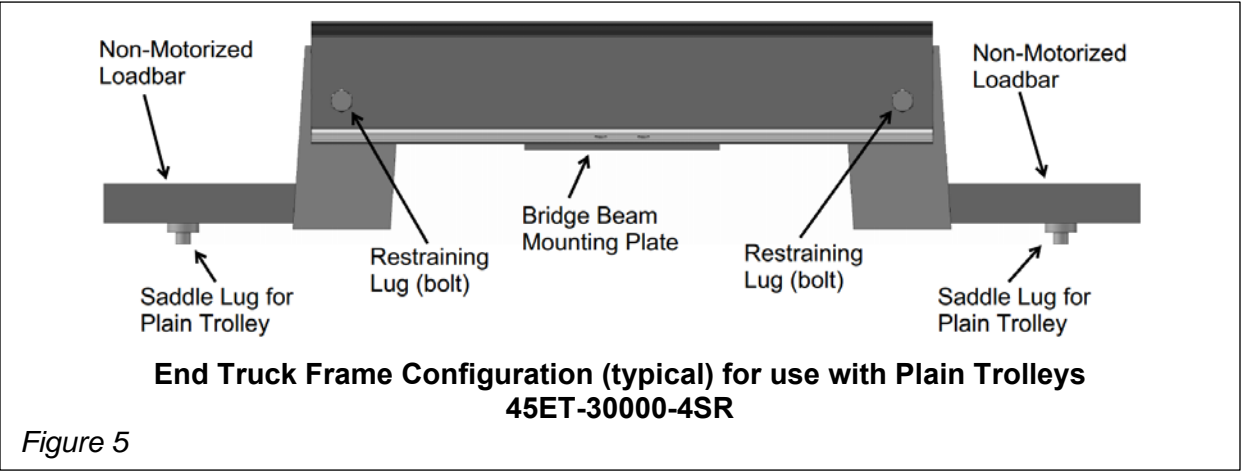

Figure 5

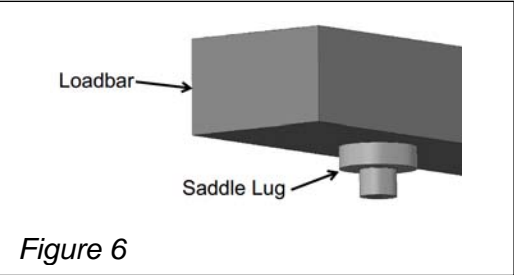

Figure 6

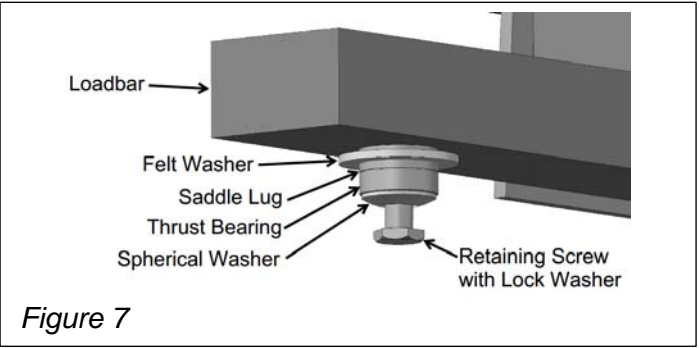

Figure 7

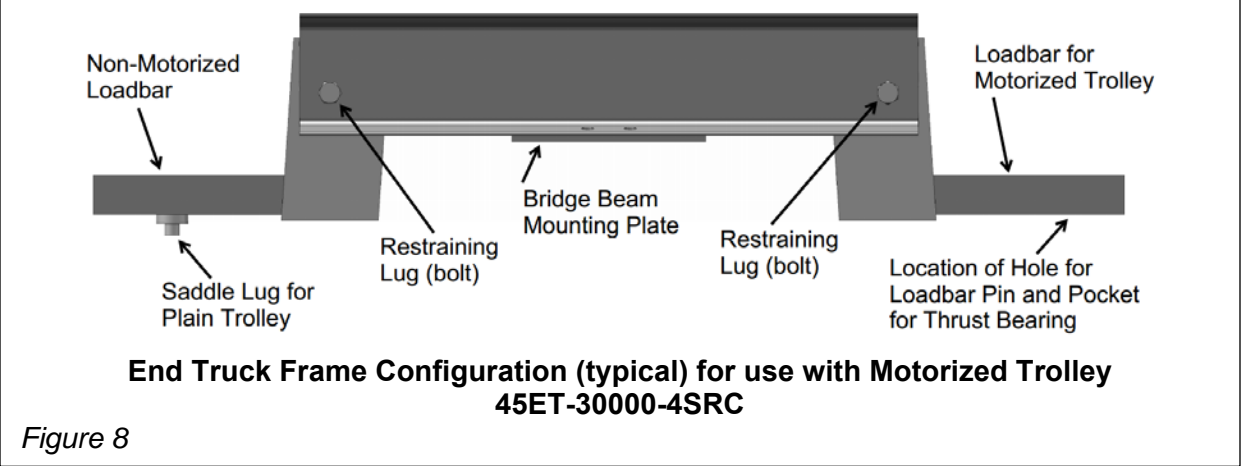

Figure 8

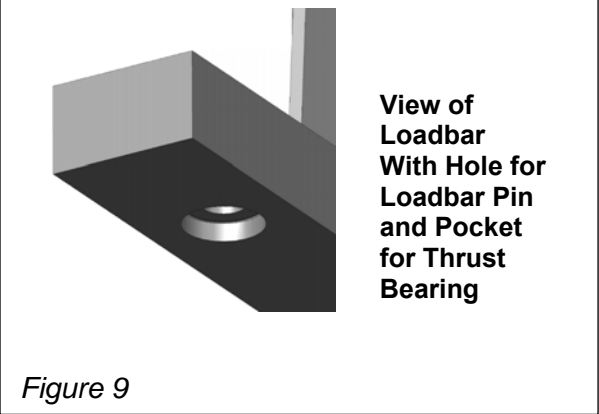

Figure 9

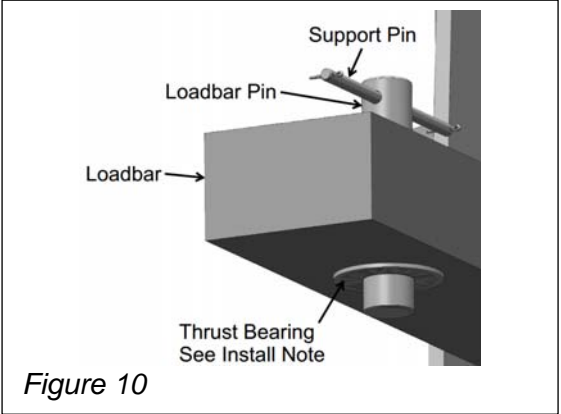
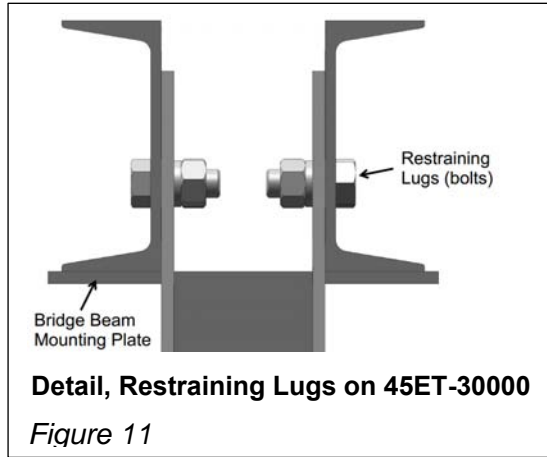

Figure 10



Restraining lugs provided on 45ET-30000-4SR or 45ET-30000-4SRC end trucks are 1 1/8" bolts installed as shown in Figures 1, 2, 5, 8 and 11.

**Procedure and Options to install 45ET-30000-4SR or 45ET-30000-4SRC end trucks on rail:**

a) Plain Trolleys

1. Place trolleys on rail
2. Remove restraining lugs from end truck
3. Lift crane into position under rail
4. Roll plain trolleys onto each end of end truck, verify spherical washer, thrust bearing and felt washer (dust shield) are in place in (see Fig. 7)
5. Set saddle lug into each trolley

Motorized Trolleys

6. For motorized trolleys, the motor must be removed from the gearbox to allow clearance to insert the loadbar pin from the bottom of the loadbar and into the hole in the loadbar. (see Figs. 4, 9, 10 and 12). For complete instructions, see *Motorized Trolley Installation Instructions*.

**INSTALL NOTE: Remove/discard thrust washer.** The "C" drive motorized trolley assembly may be shipped with a thrust washer installed on the loadbar pin. This thrust washer is to be removed and discarded. Loadbars on 450 Series end trucks and carriers are provided with a thrust bearing, which takes the place of the thrust washer.

7. Reassemble restraining lugs

b)

1. Install trolleys on end truck.
2. Remove trolley wheels from each trolley yoke, leaving yokes attached to end truck frame.
3. Remove restraining lugs from end truck
4. Lift crane into position under rail, with yokes straddling rail
5. Reassemble trolley wheels to yokes.
6. Reassemble restraining lugs

c)

1. Thread assembled end trucks and trolleys of crane or carrier onto rails at open ends (end stop removed)

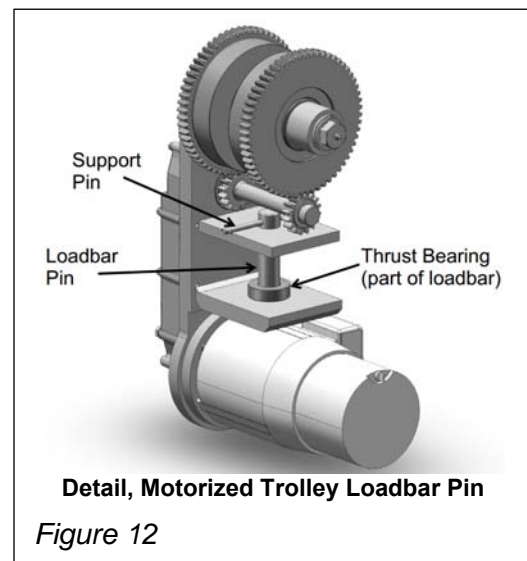

**8-Wheel End Trucks**

<b>45ET-60000-8SR</b>	6'-0" wheelbase	Figure 13
<b>45ET-60000-8SRC</b>	6'-0" wheelbase	Figure 14
<b>45ET-60000-8SR</b>	9'-0" wheelbase	Not Shown
<b>45ET-60000-8SRC</b>	9'-0" wheelbase	Figure 15

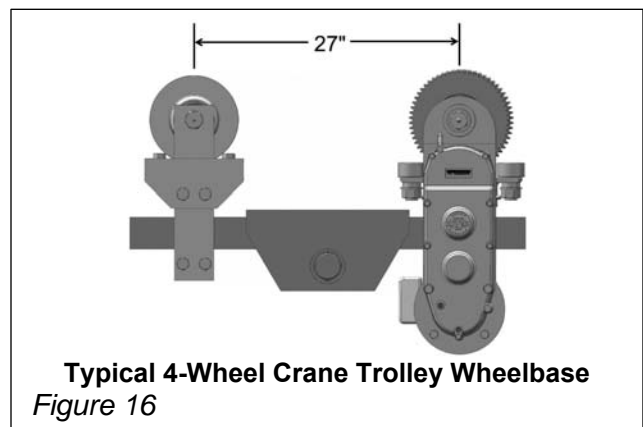
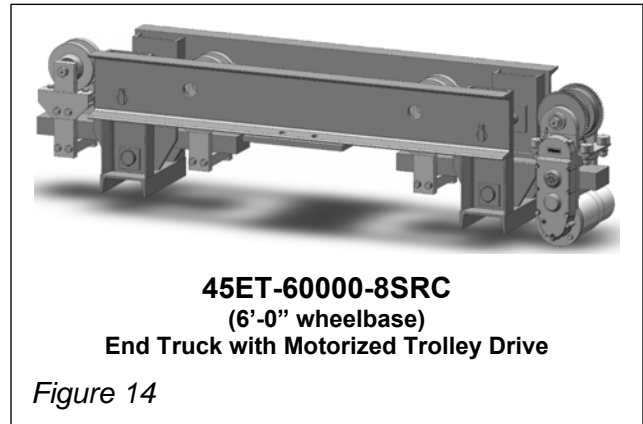
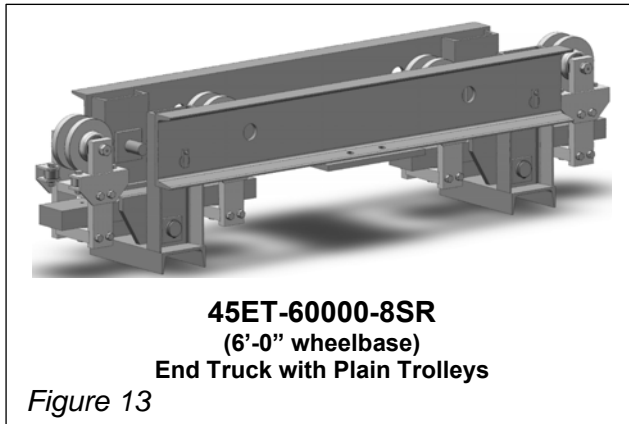

For general end truck assembly and components of 8-wheel units, see Figures 16 through 23.

- Figure 16: typical 4-wheel crane trolley wheelbase (motorized and plain)
- Figure 17: detail of end truck frame construction for attachment of 4-wheel trolley loadbar
- Figure 18: 4-wheel trolley assembly, with motorized trolley
- Figure 19: detail of trolley loadbar pin
- Figure 20: configuration of end truck frame for use with four plain (idler) trolleys
- Figure 21: configuration of end truck frame for use with three plain (idler) trolleys and a motorized trolley

NOTE: see Figures 6 and 7 for detail of connection of two-wheel plain trolleys to the loadbar, and Figures 9, 10, 12 and 24 for detail of connection of motorized trolley.





Figure 17

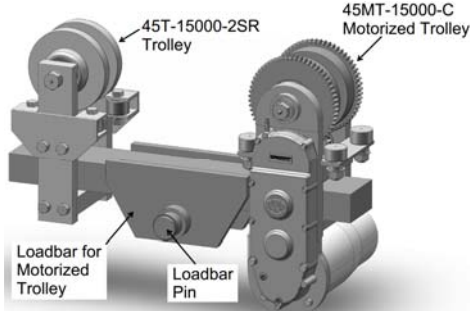
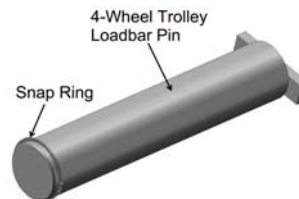

Figure 18



**4-Wheel Trolley Loadbar Pin**

Figure 19

**End Truck frame Configuration – for 45T-15000 Idler Trolleys and 45MT-15000-C Motorized Trolley on loadbars**

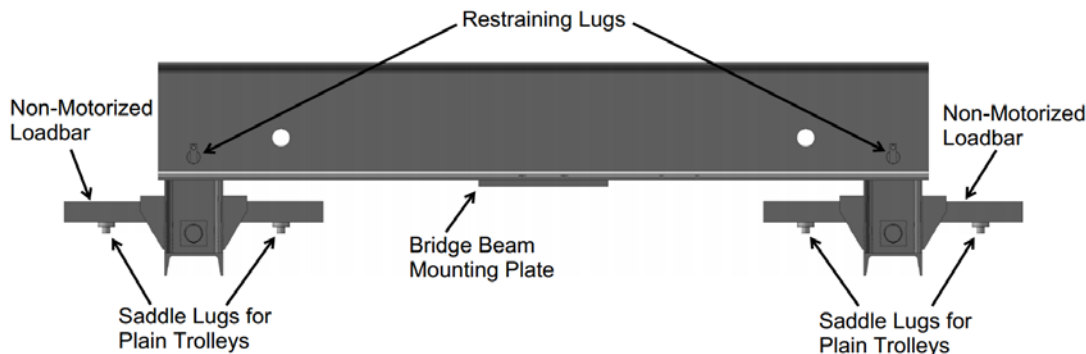

**End Truck Frame Configuration (typical) for use with Plain Trolleys  
45ET-60000-8SR**

Figure 20

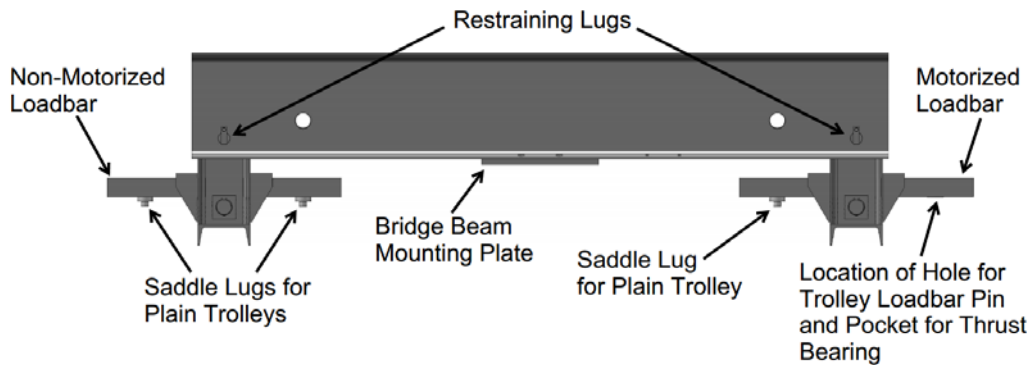

**End Truck Frame Configuration (typical) for use with Motorized Trolley  
45ET-60000-8SRC**

Figure 21

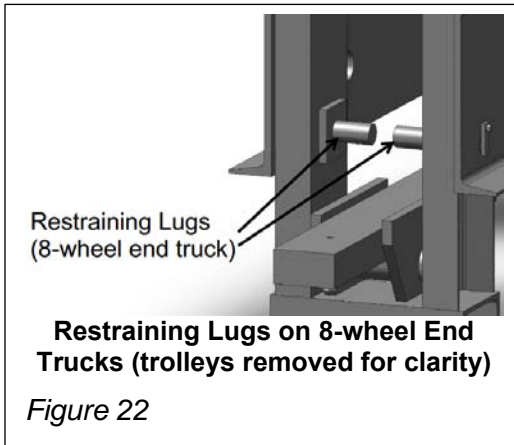

Restraining lugs provided on 45ET-60000-8SR or 45ET-60000-8SRC end trucks are fabricated items, installed as shown in Figures 22 and 23.

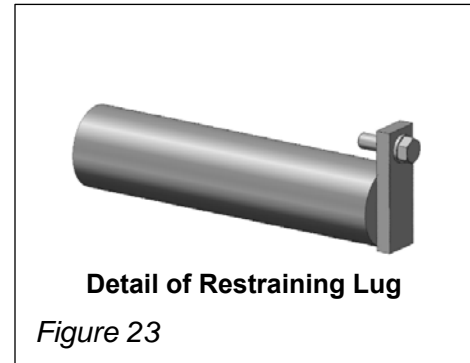

**Procedure and Option to install 45ET-60000-8SR and 45ET-60000-8SRC end trucks on rail:**

a) Plain Trolleys

1. Place trolleys on rail, in location relative to their final position on the end truck
2. Remove restraining lugs from end truck (see Figs. 22 and 23)
3. If 4-wheel trolley loadbars were removed for shipping, install as shown in Figures 17 to 21
4. Lift crane into position under rail
5. Roll plain trolleys onto each end of end truck loadbar, verify spherical washer, thrust bearing and felt washer (dust shield) are in place in (see Fig. 7)
6. Set saddle lug into each trolley

Motorized Trolleys

6. For motorized trolleys, the motor must be removed from the gearbox to allow clearance to insert the loadbar pin from the bottom of the loadbar and into the hole in the loadbar. (see Figs. 4, 9, 10 and 24). For complete instructions, see *Motorized Trolley Installation Instructions*.

**INSTALL NOTE: Remove/discard thrust washer. The “C” drive motorized trolley assembly may be shipped with a thrust washer installed on the loadbar pin. This thrust washer is to be removed and discarded. Loadbars on 450 Series end trucks and carriers are provided with a thrust bearing, which takes the place of the thrust washer.**

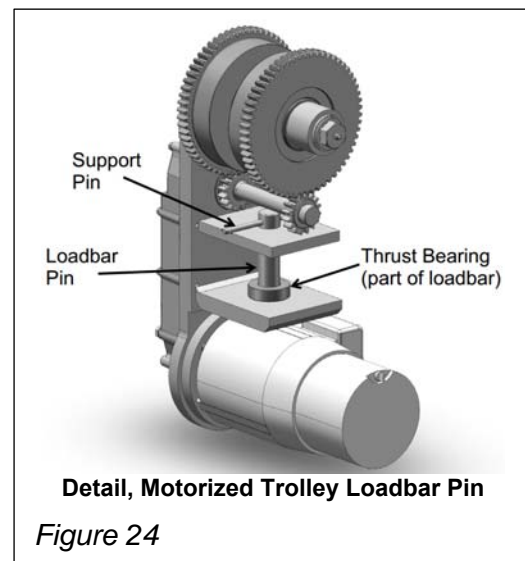

7. Reassemble restraining lugs

b)

1. Install trolleys on end truck.
2. If 4-wheel trolley loadbars were removed for shipping, install as shown in Figures 17 to 21
3. Remove trolley wheels from each trolley yoke, leaving yokes attached to end truck frame.
4. Remove restraining lugs from end truck (see Figs. 22 and 23)
5. Lift crane into position under rail, with yokes straddling rail
6. Reassemble trolley wheels to yokes.
7. Reassemble restraining lugs

c)

1. Thread assembled end trucks and trolleys of crane or carrier onto rails at open ends (end stop removed)

## Drive Tire Adjustment

**Center motor driven cranes with tire drives:** correct pressure of drive tires to the bottom of the patented track tee section is very important. Excessive tire pressure by over-tightening will cause tire failure and put undue stress on other parts of the drive system. Inadequate tire pressure will cause the tire to slip and make starts and stops difficult to control.

Tire pressure adjustments should be done when the crane is fully loaded, or at the maximum typical load. This adjusting process is the same for new installations or for tire replacement on older cranes.

Begin adjustment procedure with the drive tire just touching the underside of the tee section, and all pressure adjusting nuts snug (note: the view in Fig. 25 is a typical drive tire and bearing assembly for 325 Series end trucks; 450 Series cranes are similar). Turn the pressure nuts one full turn. Start and stop the crane. If the tires slip in either motion, adjust the pressure nuts one half turn and again start and stop the crane. If the tires slip in either direction, adjust the pressure nuts another one half turn. Continue this process until the tire does not slip at initial start or stop. Tighten the pressure nuts an additional one half turn and tighten any remaining hardware to lock in place.

### Notes:

- all drive wheels must be adjusted at the same time.
- high acceleration rates may require greater tire pressure.
- bearing support assemblies may be spring loaded or direct pressure type. See drawings.
- moisture, dirt, oils from a manufacturing process, or paint on the underside of the tee section may affect the ability of a tire to resist slipping. Clean as required.

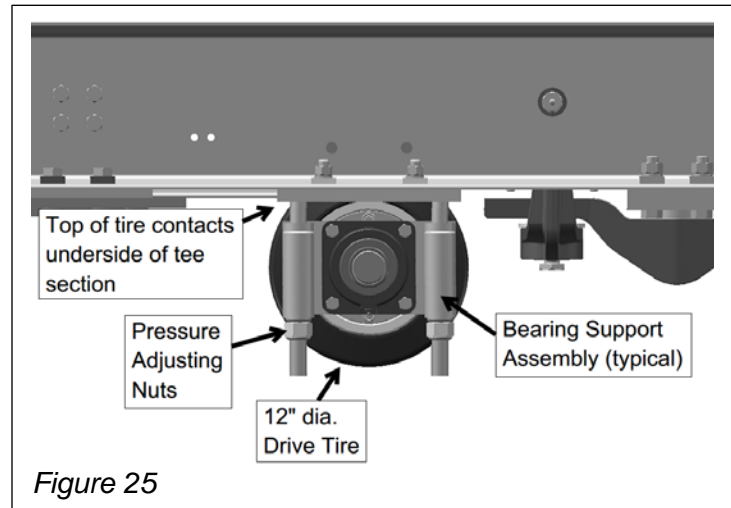

## ⚠ WARNING

### Drive Tire Pressure Adjustment Process

**Use extreme caution while performing Drive Tire Pressure adjustments. Access to the drive tire area of a crane is likely done with a manlift or similar equipment. Be sure all personnel doing the adjustments are clear of the crane before engaging the crane controls for crane movement. Persons operating the crane must have a clear view to the drive tire areas and must coordinate the method of communication between themselves and the mechanics before the process is begun.**

## Lubrication

### General Lubrication Information

See TC/American Crane *450 Series Trolley Installation Instructions* for Idler trolley lubrication and *Motorized Trolley Installation Instructions* for Motorized Trolley lubrication.

**NOTE:** before lubricating equipment that will be taken onto a customer's site, check with the customer for any preferences on brands or types (to maintain customer stock uniformity of products used and records maintenance).

**NOTE:** have Material Safety Data Sheet (MSDS) info available for any lubricants brought onto a work site.

**NOTE:** verify with customer that lubricants being used will not have an effect upon any production processes.