

## Trolleys

### 325 Series

These instructions are for “plain” (non-motorized) trolleys as used on TC/American Crane 325 Series Patented Track rail.

Also refer to the TC/American Crane Systems Catalog (available on the TC/American Crane website, [www.tcamerican.com](http://www.tcamerican.com)).

 **DANGER**

**Lifting Operations**

Installation of equipment such as TC/American Crane’s Trolleys requires performance of overhead lifting operations. Proper lifting procedures involve training, skills and experience beyond the scope of this document. Workplace supervisors are responsible to assure that all persons under their supervision are properly trained, properly equipped, and are following safety practices appropriate for the lifting operation being employed.

 **DANGER**

**Overhead Mechanical Assembly**

Persons performing installation and assembly of overhead equipment must use caution while lifting, assembling and adjusting components. These operations are frequently conducted from manlifts or platforms that require specific knowledge, training and operation skills beyond the scope of this document.

Access to the floor below the work area must be restricted to reduce the potential of personnel injury due to falling objects.

Workplace supervisors are responsible to assure that all persons under their supervision are properly trained, properly equipped, and are following appropriate safety practices.

Index

<u>Item</u>	<u>Page</u>
A. General Safety Cautions .....	1
B. Trolley Model Numbers and Descriptions .....	3
C. General Installation Instructions	
D. Before Beginning Installation .....	4
E. Installing Trolleys on Rail .....	4
F. Trolleys Mounted on End Trucks .....	4
G. Trolleys with Electrical Collectors .....	4
H. Initial Start-Up .....	4
I. 325 Series Trolleys	
J. 3T-750-2, 3T-1150-4, 3T-750-2L, 3T-1150-4L .....	5
K. 3T-850-2, 3T-1200-4, 3T-850-2L, 3T-1200-4L .....	6
L. 3T-2000-2, 3T-2000-2L, 3T-2800-4, 3T-2000-2SR, 3T-2800-4SR, 3T-3100-4, 3T-3100-4SR, 3T-3100-4CC.....	7, 8,9
M. 3T-2700-2, 3T-2700-2E, 3T-2700-2SR, 3T-2700-2SRE, 3T-2700-2C 3T-2700-2SRC.....	10
N. 3T-5400-4, 3T-5400-4SR.....	11
O. 3T-6200-2, 3T-6200-2SR, 3T-8000-2, 3T-8000-2SR .....	12
P. 3T-12400-2, 3T-12400-2SR, 3T-16000-2, 3T-16000-2SR .....	13
Q. 3T-24800-8, 3T-24800-8L, 3T-24800-8SR, 3T-24800-8SRL .....	14
R. 3T-10000-2SR, 3T-20000-4SR, 3T-20000-4SRL.....	15
S. Lubrication	
T. General Lubrication Information .....	16
U. Lubrication Frequency .....	16
V. Recommended Lubricants .....	16
W. Fittings .....	17,18,19

## Trolleys

TC/American Crane offers several models of trolleys. Selection of the appropriate model depends upon the size of the rail on which the trolley will operate, the load to be carried on the trolley, curved or straight rail, type of fittings required, service duty class, and possibly other factors.

### Trolley Model Numbers:

(general information for all trolleys)

- The first character(s) of the Model Number denotes the rail size on which the trolley operates:
  - 2 = 200 Series Rail
  - 3 = 325 Series Rail
  - 4 = 400 Series Rail
  - 45 = 450 Series Rail
  
- The second character, "T," identifies the product as a "Trolley."
  
- The intermediate numbers are the trolley capacity; i.e.:
  - 2000 = 2000 pound capacity
  - 5600 = 5600 pound capacity
  - 12400 = 12400 pound capacity
  - 16000 = 16000 pound capacity
  - etc.
  
- The last number, or number and letters, identify the trolley model
  - 2 = 2-wheel trolley with flanged wheels
  - 2SR = 2-wheel trolley with flangeless wheels and side rollers ("SR")
  - 4 = 4-wheel trolley with flanged wheels
  - 4SR = 4-wheel trolley with flangeless wheels and side rollers ("SR")
  - 8 = two 4-wheel trolleys connected by a secondary loadbar, with flanged wheels
  - 8SR = two 4-wheel trolleys connected by a secondary loadbar, with flangeless wheels and side rollers ("SR")
  - 2L = 2-wheel "laundry trolley" (no grease in bearings, no grease fitting)
  - 4L = 4-wheel "laundry trolley" (no grease in bearings, no grease fitting)
  - 8L = 8-wheel trolley with longer wheelbase than basic trolley
  - 4SRL = 4-wheel trolley with longer wheelbase than basic trolley
  - 8SRL = 8-wheel trolley with longer wheelbase than basic trolley
  - 2C = Crane trolley (applies only to 3T-850-2C, 3T-850-2C, 3T-2700-2C and 3T-2700-2SRC trolleys)
  - 4CC = 4-wheel, "close coupled" trolley (shorter wheelbase than basic trolley)
  - 8CC = 8-wheel, "close coupled" trolley (shorter wheelbase than basic trolley)

### Trolley Part Numbers

Trolleys and Fittings are ordered and shipped by an associated computer (part) number. See the TC/American Crane Systems Catalog and Price List for part numbers.

**NOTE: See the appropriate section(s) of these instructions for assembly, installation and maintenance details specific to your Trolley model.**

**NOTE: For a specific parts breakdown of the Trolley provided with an order, see the drawings provided with that shipment and the Trolley Section of TC/American Crane Systems Catalog.**

---

## General Installation Instructions

### Before beginning the installation:

- When shipment is received, remove all shipping materials and check all parts for damage. Repair and/or replace if necessary.
- Check packing lists against materials received and identify all parts.
- Gather all TC/American Crane and other vendor equipment drawings and associated manuals (motor, reducer, brake, electrical components, etc.) as applicable and keep in a secure location for reference during installation and start-up, and to give to end user for future reference.
- Turn trolley wheels and guide rollers by hand to check for possible damage in shipment. Check for rough bearings, loose bearings and axles.
- Check electrical collectors (if provided) for condition and proper operation. Check collector wiring for routing and security.
- Store all equipment in a clean, secure area prior to final assembly.

### Installing Trolleys on rail:

- Orient all components relative to their eventual position when assembled on the rail (i.e., if being used with a drivetractor, etc.).
- Trolley assemblies can be threaded onto an open end of rail (remove end stop). If there is no open end, or if obstructions or other barriers prevent access to an open end, install trolleys on the rail by removing trolley wheels from the trolley yoke. Reinstall wheels after the yoke is in place, straddling the riding tread of the rail.
- Before installing trolleys on rail, verify that appropriate fittings (stud swivels, load hooks, load eyes, etc.) are installed.
- For trolleys where a fitting is captured within a “pocket” in the cast yoke, or a spherical seat rests in the machined pocket in the yoke, be sure these areas are clean and smooth, and that the head of the fittings are free to pivot within the yoke. The pocket of these trolleys does not require lubrication, but a coating of good quality EP grease may be applied if desired.
- Lift into position on runway or monorail and re-assemble. Use extreme caution when lifting trolleys and other equipment into place.

### Trolleys mounted on End Trucks

- Crane end trucks or carriers may use 3T-850-2C, 3T-2000-2, 3T-2000-2SR, 3T-2700-2C, 3T-2700-2SRC, 3T-6200-2, 3T-6200-2SR, 3T-8000-2, 3T-8000-2SR or 3T-10000-2SR 2-wheel trolleys, or combinations of certain 2-wheel trolleys to make 4-wheel trolleys. For more detail, see *325 Series End Truck Installation Instructions*.

### Trolleys with Electrical Collectors:

- For trolleys provided with electrical collectors, see *Electrical Collectors Installation Instructions*. Use extreme caution when working around electrical conductors.

### Initial Start-Up:

- Operate trolleys through entire system.
- Check clearances of all portions of trolleys, fittings, load bars or other attachments or carrier structure through curves and switches.

### 325 Series Trolleys

- 3T-750-2            Figure 1
- 3T-1150-4        Figure 3
- 3T-750-2L        Figure 1A
- 3T-1150-4L       (not shown)

3T-750-2 and 3T-1150-4 have trolley wheel axles with grease fittings, and the bearings are greased. 3T-750-2L and 3T-1150-4L have wheels with light oil only in the bearings, and an oil port in the head of the axle bolt. Port is sealed with a plastic plug. See Fig. 1A.



Fig. 1A

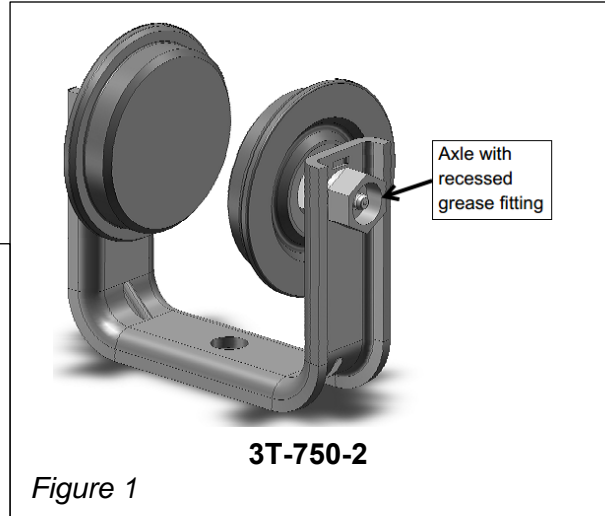

Figure 1

#### Wheel Locking Tab:

To prevent the trolley wheel hub from rotating during operation, the hex head of the wheel bushing is held by a locking tab stamped into the yoke. See Figure 2.

To mount trolley wheel to yoke, position one of the flats on the bushing against the tab as shown, then tighten wheel axle into the wheel bushing until lock washer is firmly compressed. Hold hex head of wheel bushing with 15/16" wrench, turn head of axle with 7/8" wrench (3/4" wrench for axle bolt with oil port).

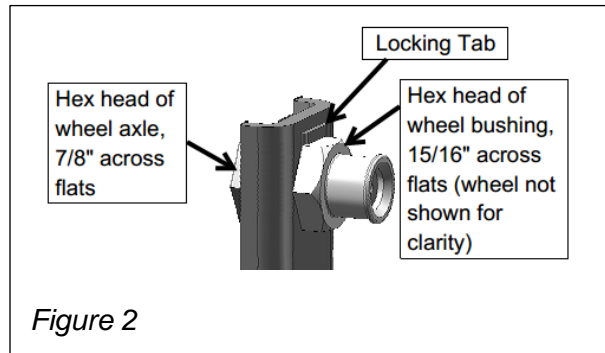

Figure 2

#### 4-Wheel Trolley

The loadbar for a 3T-1150-4 or 3T-1150-4L is held in place with cotter pins, as shown in Figure 3. For some specialized applications, the trolley loadbar may be mounted under the trolley yokes (underhung loadbar).

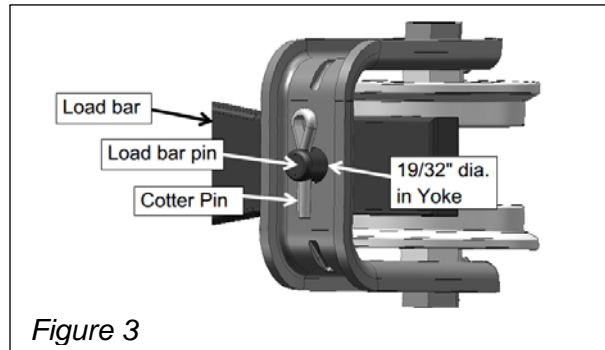

Figure 3

#### Fittings

See the Trolley Section of the TC/American Crane Systems Catalog and the Price List for fittings or load carrying devices available for these trolleys. Standard fittings include Load Eye and Load Hook. Other specialized fittings, such as laundry hooks, may also be used.

Fittings are installed either in the 19/32" hole in the bottom of the 2-wheel trolley yoke (see Fig. 3), or the 11/16" hole in the center of the loadbar of 4-wheel trolley (see Fig. 4).

See *Fittings* section of these instructions for more detail.

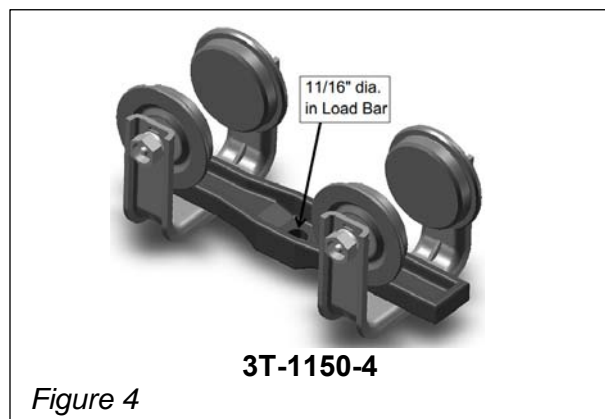

Figure 4

### 325 Series Trolleys

**3T-850-2** Figure 5 **3T-850-2L** (not shown)  
**3T-1200-4** Figure 8 **3T-1200-4L**(not shown)

3T-850-2 and 3T-1200-4 have trolley wheel axles with grease fittings, and the bearings are greased. 3T-850-2L and 3T-1200-4L have wheels with light oil only in the bearings, and an oil port in the head of the axle bolt. Port is sealed with a plastic plug. See Fig. 5A, 3T-750-2L shown.

#### Wheel Locking Tab:

See Figure 6 (wheel hidden for clarity).

To prevent the trolley wheel hub from rotating during

operation, the hex head of the wheel bushing is held by a locking tab stamped into the yoke.

To mount trolley wheel to yoke, position one flat on the bushing against the tab as shown, then tighten wheel axle into the wheel bushing until lock washer is firmly compressed. Hold hex head of wheel bushing with 15/16" wrench, turn head of axle with 7/8" wrench (3/4" wrench for axle bolt with oil port).

#### 4-Wheel Trolley

The loadbar for a 3T-1200-4 or 3T-1200-4L is held in place with cotter pins, as shown in Figure 7. For some specialized applications, the trolley loadbar may be mounted under the trolley yokes (underhung loadbar).

#### Fittings

See the Trolley Section of the TC/American Crane Systems Catalog and the Price List for fittings or load carrying devices available for these trolleys. Standard fittings include Load Eye and Load Hook. Other specialized fittings, such as laundry hooks, may also be used.

Fittings are installed either in the 19/32" hole in the bottom of the 2-wheel trolley yoke (see Fig. 3), or the 11/16" hole in the center of the loadbar of 4-wheel trolley (see Fig. 8).

See *Fittings* section for more detail.

#### 3T-850-2C Crane Trolley

Similar to 3T-850-2, as shown in Figure 5, but with an 11/16" hole in bottom of the yoke to fit load bar pin on a 3ET-1300-4 End Truck (see *End Trucks Installation Instructions*).

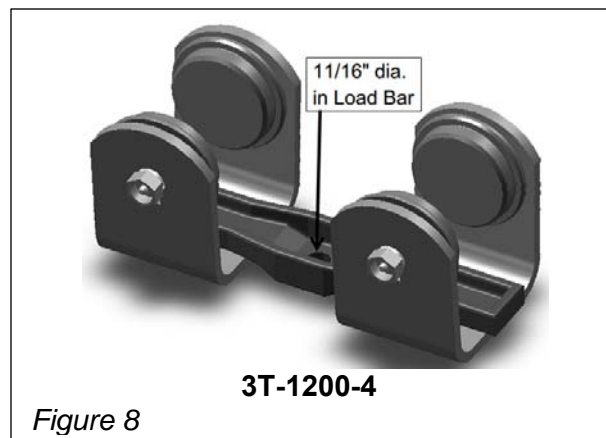
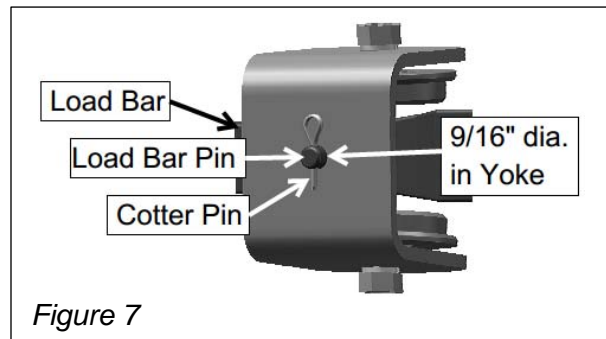
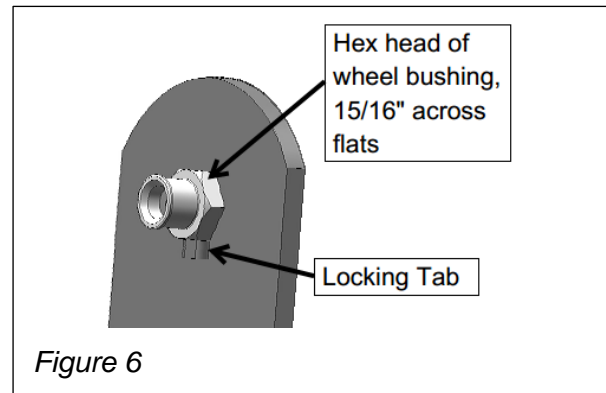
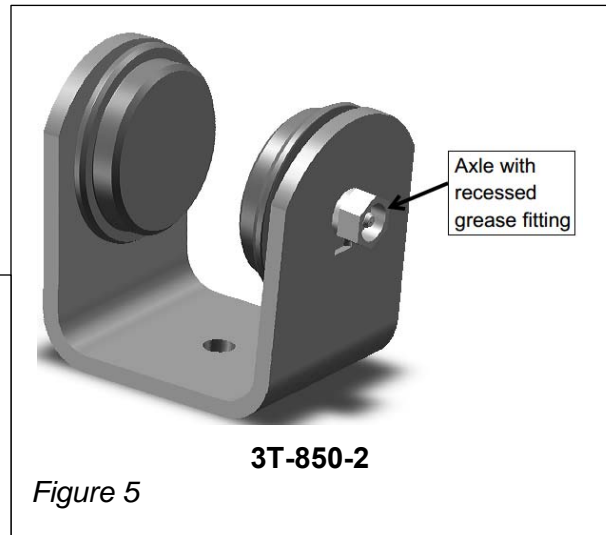
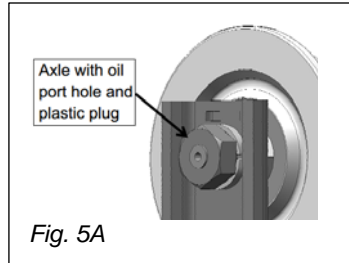

**325 Series Trolleys**

<b>3T-2000-2</b>	Figure 9	4" dia. wheels
<b>3T-2800-4</b>	Figure 14, Page 8	4" dia. wheels
<b>3T-2000-2SR</b>	Figure 10	4" dia. wheels
<b>3T-2800-4SR</b>	(not shown)	4" dia. wheels
<b>3T-3100-4</b>	(not shown)	4" dia. wheels
<b>3T-3100-4SR</b>	(not shown)	4" dia. wheels
<b>3T-3100-4CC</b>	Figure 15, Page 8	4" dia. wheels

The trolleys above all feature "bolt-together" yokes, as shown in Figures 9 and 10.

Trolleys have grease fittings recessed in end of axle as shown in Figure 11.

The wheel and axle is an assembly and must be replaced as a unit.

The axle is locked (prevented from turning) by the trolley yoke clamp bolts and a groove in the axle, as shown in Figure 12. This also sets the wheel-to-wheel spacing for the trolley.

Side Rollers are standard on trolleys with flangeless wheels (see Figures 10 and 13).

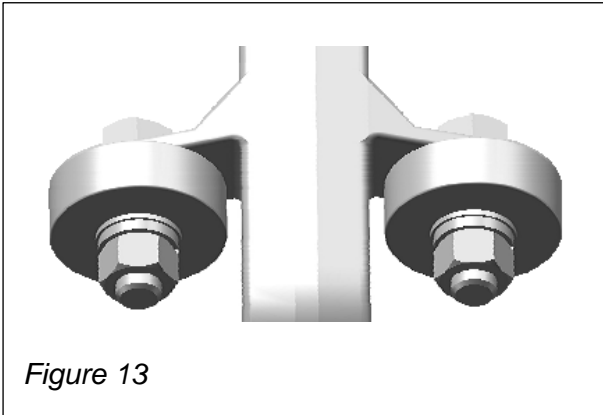
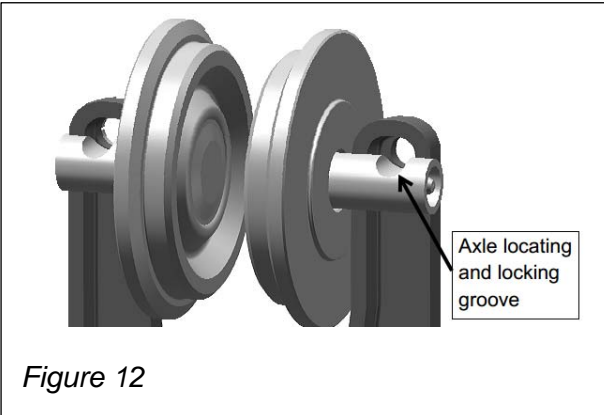
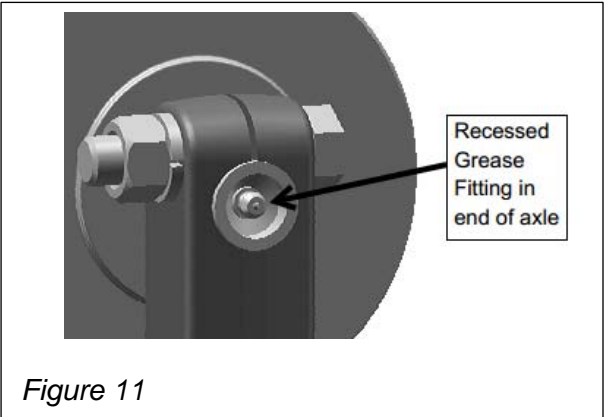

**4-Wheel Trolleys**

**3T-2800-4; 3T-2800-4SR;  
3T-3100-; 3T-3100-4SR; 3T-3100-4CC**

Four-wheel trolleys consist of two 2-wheel trolleys, (either 3T-2000-2 or 3T-2000-2SR) coupled with a Load Bar. See example of 3T-2800-4 shown in Figure 14.

Swivel Heads on the loadbar (see Fig. 14A) are securely held in pockets of the two-wheel trolleys (see Fig. 17, Page 9).

Note: a 3T-3100-4 or 3T-3100-4SR trolley is same as a 3T-2800-4 or 3T-2800-4SR trolley, but with a 15" long loadbar in place of 11" loadbar.

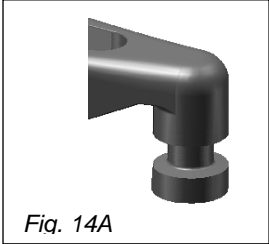
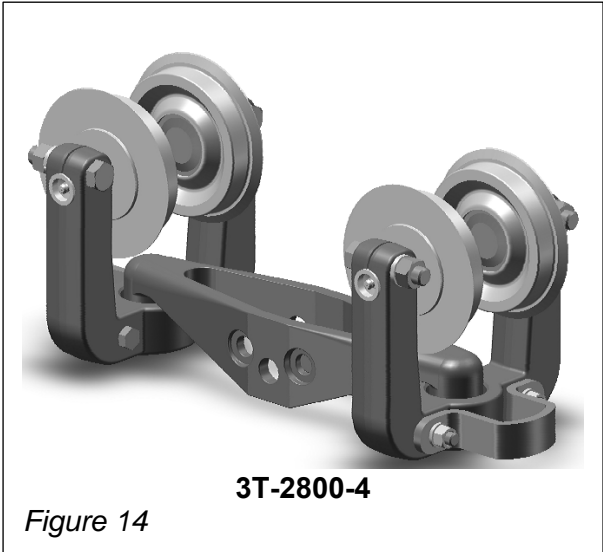

A 3T-3100-4CC trolley (see Figure 15, trolley shown with SB-213 Swivel Bushing) consists of two 3T-2000-2 trolleys coupled by a short wheelbase loadbar (6" long). This trolley is only available with the SB-123 Swivel Bushing (see Fig. 18) in the loadbar.

**Bumpers**

Four wheel trolleys only are provided from factory with bumpers at each end of the trolley (see Figure 16). Bumpers contact end stops mounted under the rail riding tread, and bumpers of other trolleys on the rail (prevents wheel-to-wheel contact).

Bumpers may also have pins for drive tractor tow bars connection welded to them (see Fig. 16A).

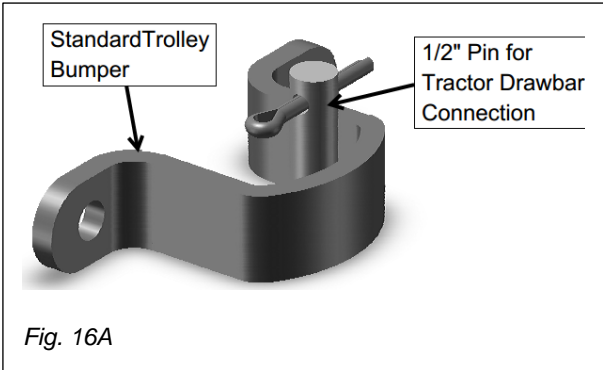
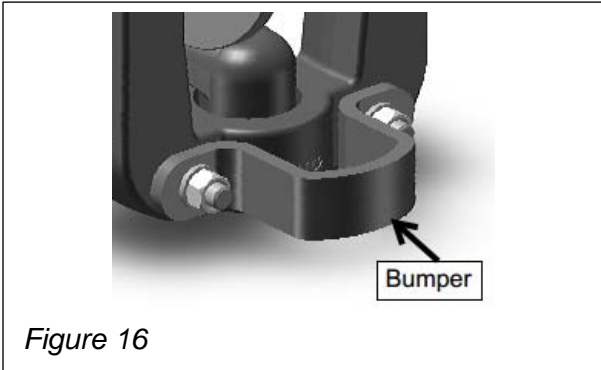
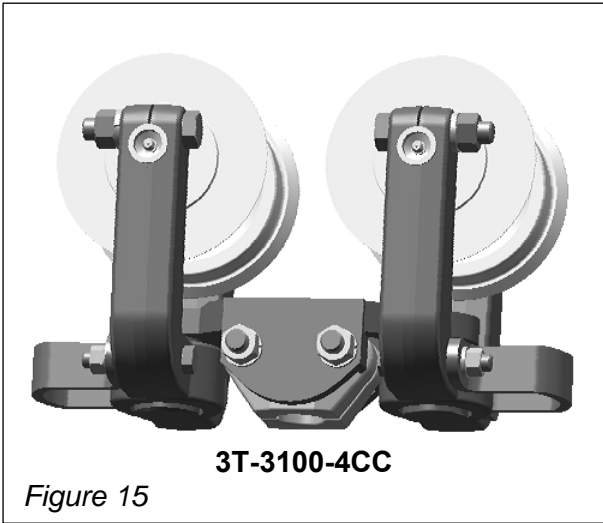



**Fittings  
(for 4-wheel trolleys)**

See the Trolley Section of the TC/American Crane Systems Catalog and the Price List for all fittings (load carrying devices) available for these trolleys. Standard fittings include Load Eye, Load Hook, Stud Swivel and various other Swivels.

Other fittings, such as laundry hooks or specially designed attachments may also be used.

Fittings are mounted by containing a swivel head or a round nut on the fitting inside the machined pocket of a 2-wheel trolley yoke (see Fig. 17, yoke half), or within a similar pocket in a Swivel Bushing (see Fig. 18 and 18A, Swivel Bushing half) installed in the load bar of a 4-wheel trolley (see Fig. 19).

For hoists or other lifting devices with a top hook, a Hook Bearing (see Fig. 20) is available for the load bar (see Fig. 19). To fit the hoist hook onto the hook bearing, it may be necessary to remove the hook bearing from the load bar, sandwich the hook between the two halves, and then replace as a unit into the load bar (depends upon hook dimensions).

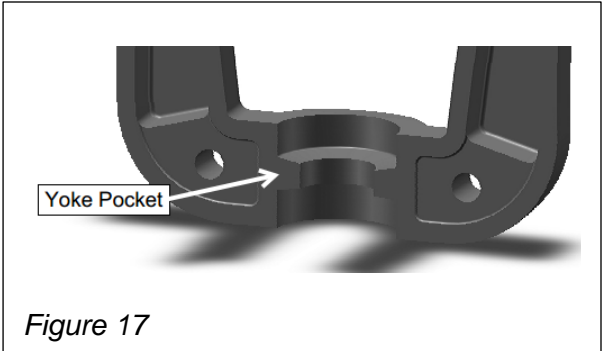

Figure 17

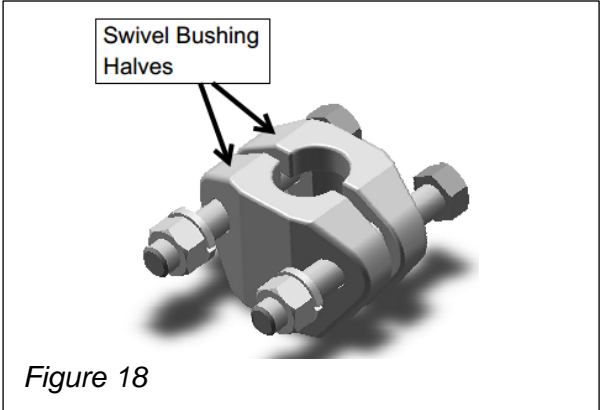

Figure 18

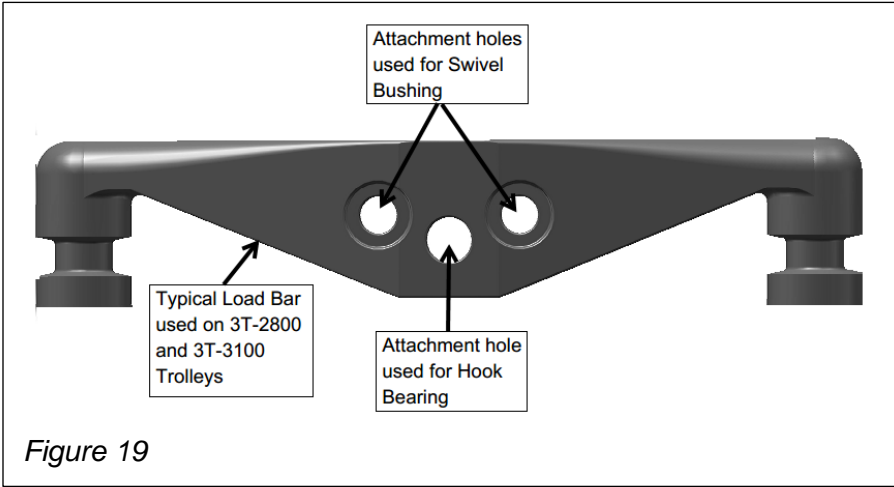
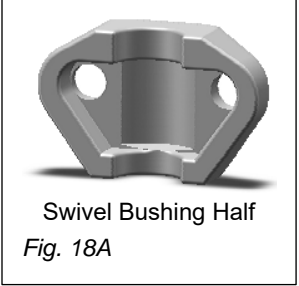

Figure 19



Swivel Bushing Half  
Fig. 18A

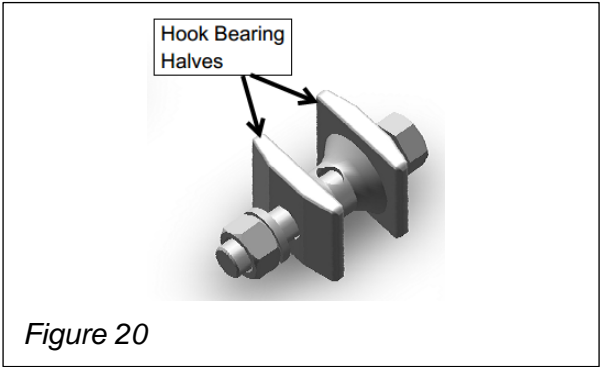

Figure 20

See *Fittings* section of these instructions for more detail.

**325 Series Trolleys**

<b>3T-2700-2</b>	Figure 21	4 1/2" dia. wheels
<b>3T-2700-2E</b>	See note below	4 1/2" dia. wheels
<b>3T-2700-2SR</b>	Figure 22	4 1/2" dia. wheels
<b>3T-2700-2SRE</b>	See note below	4 1/2" dia. wheels
<b>3T-2700-2C</b>	Not Shown	4 1/2" dia. wheels
<b>3T-2700-2SRC</b>	Not Shown	4 1/2" dia. wheels

This series of trolleys all have formed flat bar yokes, as shown in Figures 21 and 22.

Trolley wheel grease fittings are recessed in end of axle bolt as shown in Figure 25.

Trolley wheel hub is prevented from turning by a locking bar, welded to the yoke, that engages a notch in the wheel bushing. See Figure 23.

Side Rollers are standard on trolleys with flangeless wheels. See Figure 22.

Trolleys for mounting electrical collectors (3T-2700-2E; 3T-2700-2SRE) have Collector Mounting Brackets added to the yoke, as shown in Figure 24.

Trolleys for use on End Trucks (3T-2700-2; 3T-2700-2SRC) have a spherical washer with 0.94" bore, and are provided with a swivel pin for connection to the end truck saddle. See *325 Series End Truck Installation Instructions* for more detail.

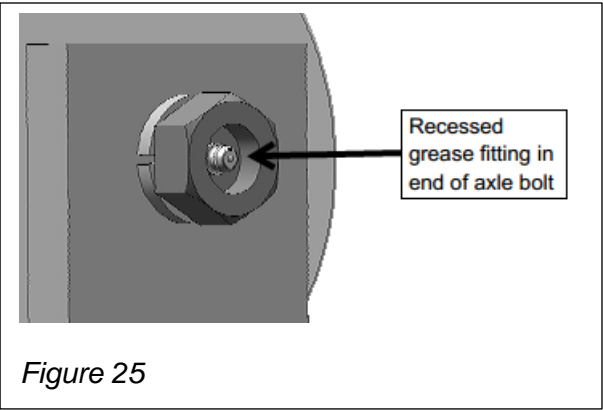
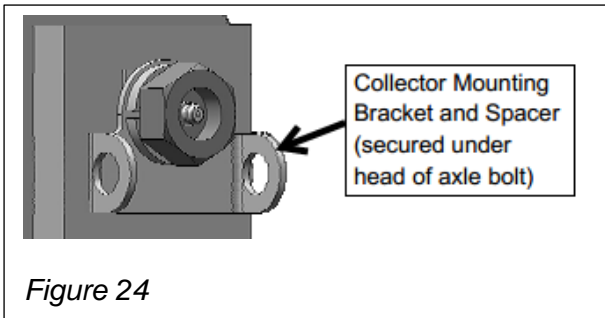
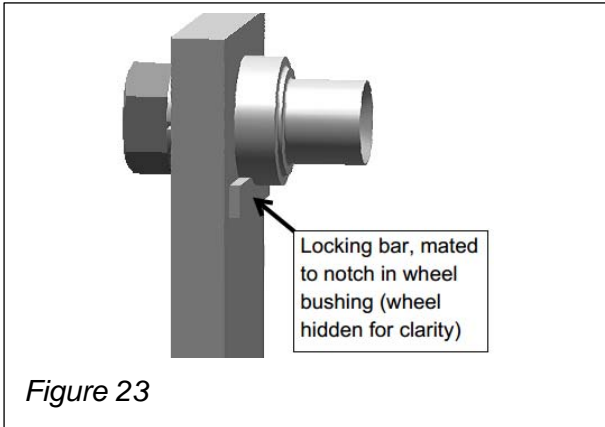
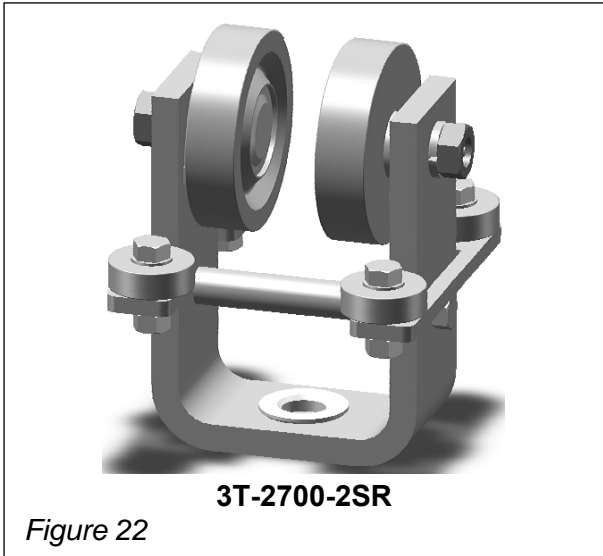
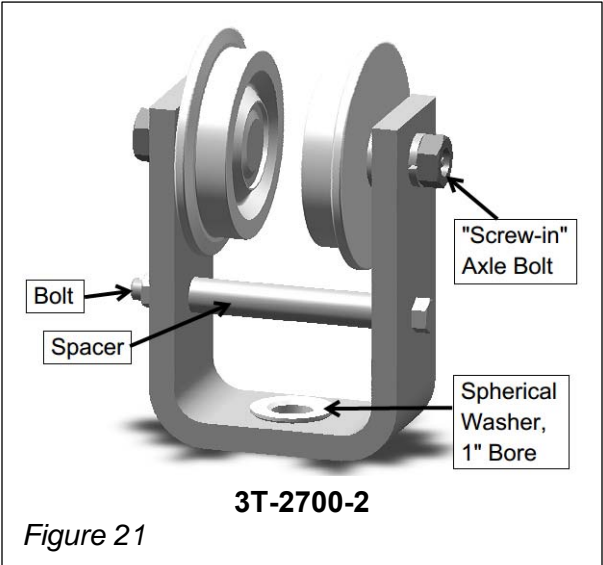

### 4-Wheel Trolleys

**3T-5400-4** Not shown  
**3T-5400-4SR** Figure 26

Four-wheel trolleys consist of two 2-wheel trolleys, (either 3T-2700-2 or 3T-2700-2SR) coupled with a Load Bar. See example of 3T-5400-4SRE (with Collector Mounting Brackets) shown in Figure 26.

If loadbar (see Figure 28) is shipped loose (not installed into 2-wheel trolley), remove trolley yoke crossbolt (see Figure 21) for clearance to install loadbar. Assure spherical washer (see Fig. 21, 22 and 27) is in place.

#### Fittings

Loadbar of 4-wheel trolleys may be equipped with a HB-217 hook bearing (see Fittings section) for a hoist top hook, or with an adapter and thrust bearing for various fittings (see Figure 29 for typical load eye configuration).

#### Bumpers

The cast loadbar of these four wheel trolleys has a bumper at each end (see Figure 26 and 27), formed as part of the loadbar. Bumpers contact end stops mounted under the rail riding tread, and bumpers of other trolleys on the rail (prevents wheel-to-wheel contact).

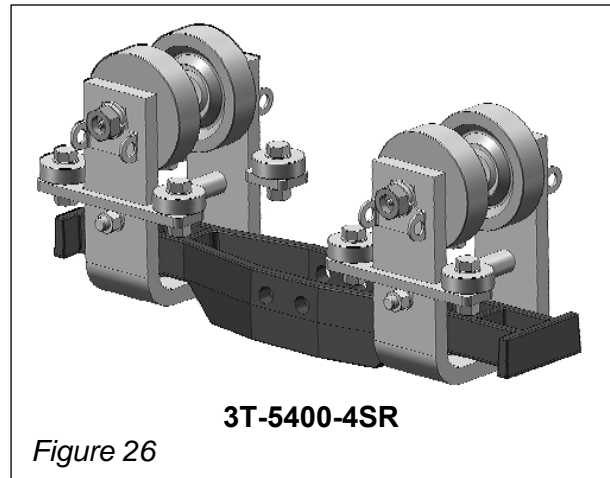

Figure 26

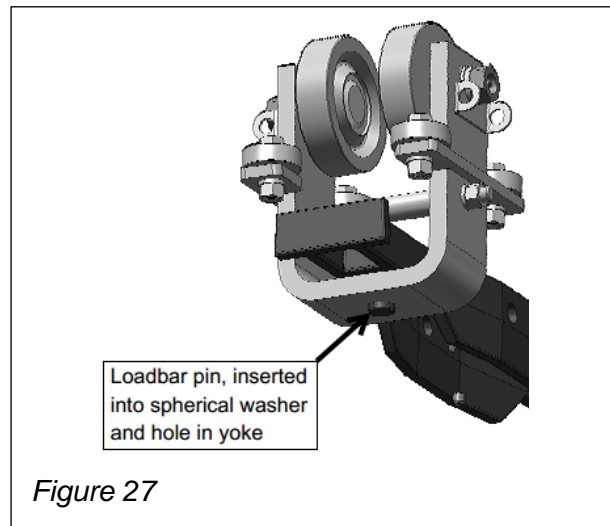

Figure 27

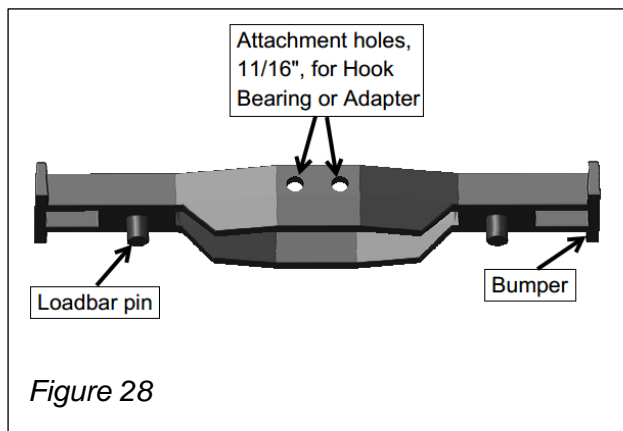

Figure 28

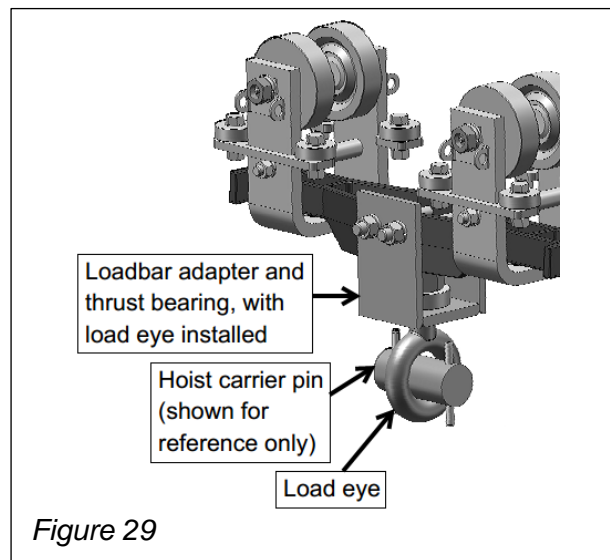

Figure 29

### 325 Series Trolleys

<b>3T-6200-2</b>	Figure 30	5" dia. wheels
<b>3T-6200-2SR</b>	Not Shown	5" dia. wheels
<b>3T-8000-2</b>	Not Shown	6 ½" dia. wheels
<b>3T-8000-2SR</b>	Figure 31	6 ½" dia. wheels

These trolleys have similar appearance and construction. All have a single piece cast yoke, with "ears" for side rollers. Yokes for 3T-6200-2 and 3T-6200-2SR are the same, as are the yokes for 3T-8000-2 and 3T-8000-2SR. Only trolleys with flangeless wheels have side rollers.

See Figure 32 for detail of wheel axle with grease fitting plus electrical collector mounting. Also see *Electrical Collectors Installation Instructions*.

See Figure 33 for yoke notch detail (holds trolley wheel hub from turning when mounting wheel on yoke). Mating part on wheel hub fits into notch.

See Figure 38, Page 13, for typical relative positions of Felt Washer, Thrust Washer and Spherical Washer in the yoke.

#### Fittings

Various Load Eye and Stud Swivel fittings may be used in these 2-wheel trolleys. See Figure 34 for a trolley with FF-8000 Flange Fitting.

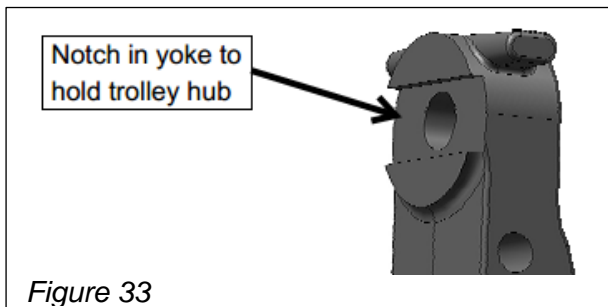
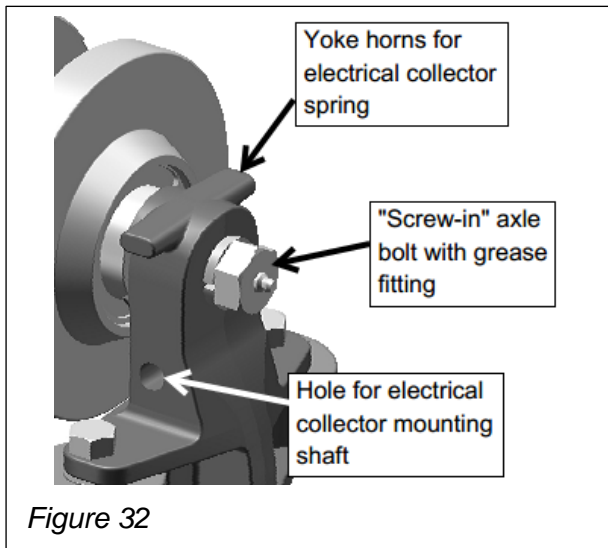
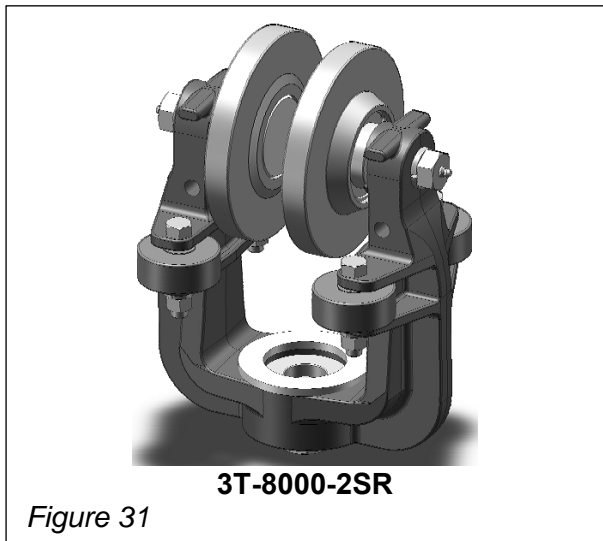
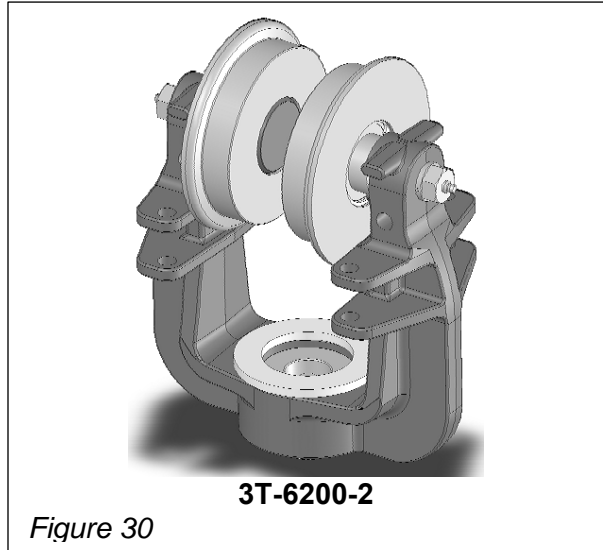

4-Wheel Trolleys

<b>3T-12400-4</b>	Figure 35	5" dia. wheels
<b>3T-12400-4SR</b>	Not shown	5" dia. wheels
<b>3T-16000-4</b>	Not shown	6 1/2" dia. wheels
<b>3T-16000-4SR</b>	Figure 36	6 1/2" dia. wheels

These four-wheel trolleys consist of two 2-wheel trolleys, 3T-6200-2, 3T-6200-2SR, 3T-8000-2 or 3T-8000-2SR, coupled by a Loadbar. See examples in Figures 35 and 36.

Felt Washer, Thrust Bearing and Spherical Washer are assembled in trolley yoke as shown in Figure 38; and in loadbar pocket as shown in Figure 39.

Fittings

Various fittings such as Load Eyes and Stud Swivels may be used in the loadbar of these trolleys. See Figure 37 for typical example.

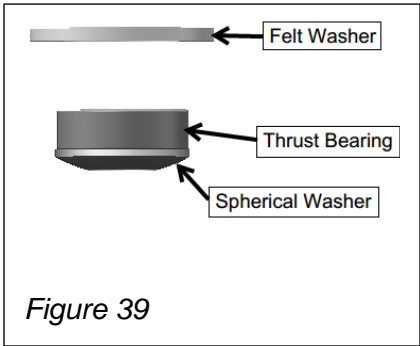
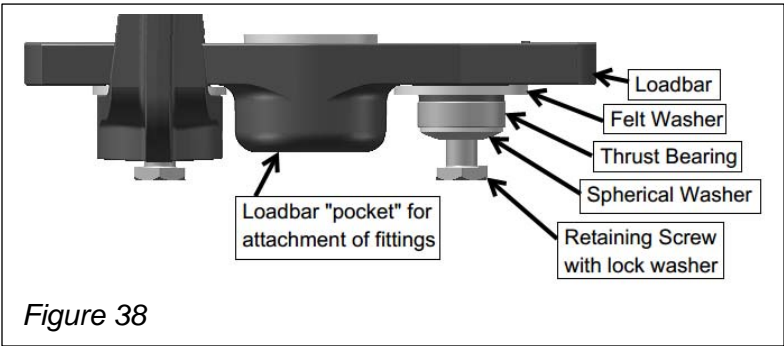
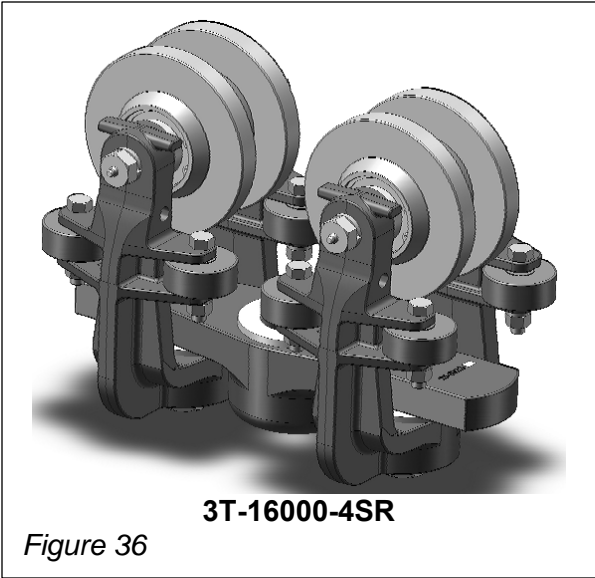
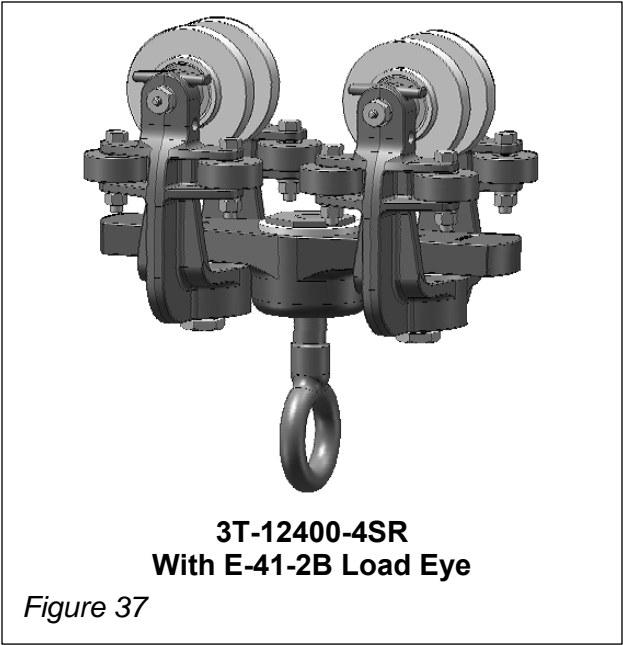
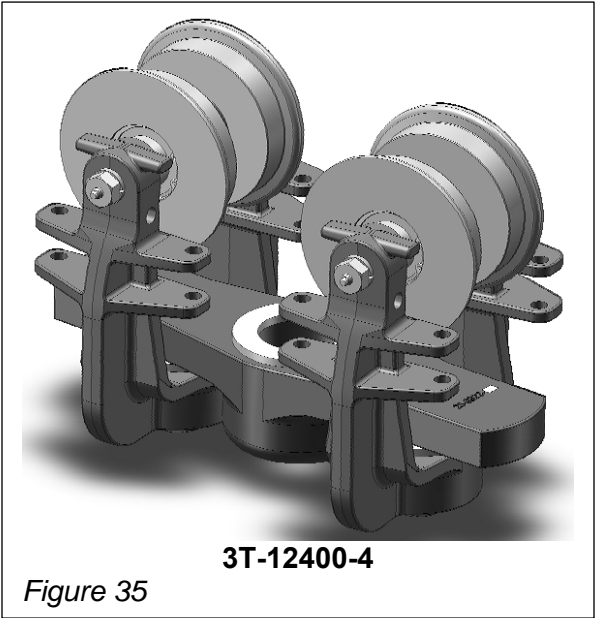

**8-Wheel Trolleys**

<b>3T-24800-8</b>	Figure 40	5" dia. wheels
<b>3T-24800-8L</b>	Not shown	5" dia. wheels
<b>3T-24800-8SR</b>	Not shown	5" dia. wheels
<b>3T-24800-8SRL</b>	Not shown	5" dia. wheels

These 8-wheel trolleys are combinations of 4-wheel trolleys, 3T-12400-4 and 3T-12400-4SR, coupled with sub-loadbar.

Trolleys with "L" suffix are modified with at least one fabricated loadbar to allow mounting of a motorized trolley.

**Fittings**

Trolley shown in Figure 40 has a hook bearing, but may also be provided with adapters for stud swivels or load eyes, or for direct bolt to a hoist frame.

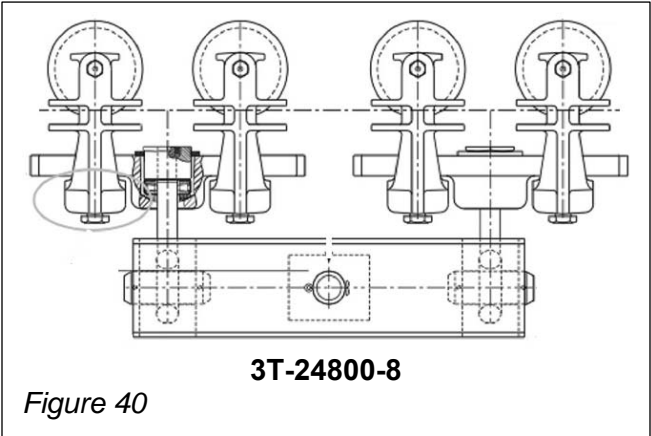

Figure 40

**325 Series Trolleys**

- 3T-10000-2SR** Figure 41 9" dia. wheels
- 3T-20000-4SR** Not Shown 9" dia. wheels
- 3T-20000-4SRL** Not Shown 9" dia. wheels

These trolleys feature a fabricated trolley yoke and are only available with flangeless wheels and side rollers. See Figure 41.

4-wheel assemblies have a fabricated loadbar. Trolleys with "L" suffix have a lengthened loadbar to allow mounting of a motorized trolley.

Axle bolt with grease fitting in head (shown in Fig. 41) screws into wheel hub which is firmly held in a machined notch in the yoke. See Figure 42.

Side roller axle bolts are installed into tapped holes in mounting bracket, as shown in Figure 44.

Felt Washer, Thrust Bearing and Spherical Washer are installed in lower plate of trolley yoke assembly as shown in Figure 43.

**Fittings**

These trolleys use custom stud swivels or load eye fittings designed for the application.

**Collectors**

These trolleys are not designed to have collectors mounted on the trolley yoke (side contact).

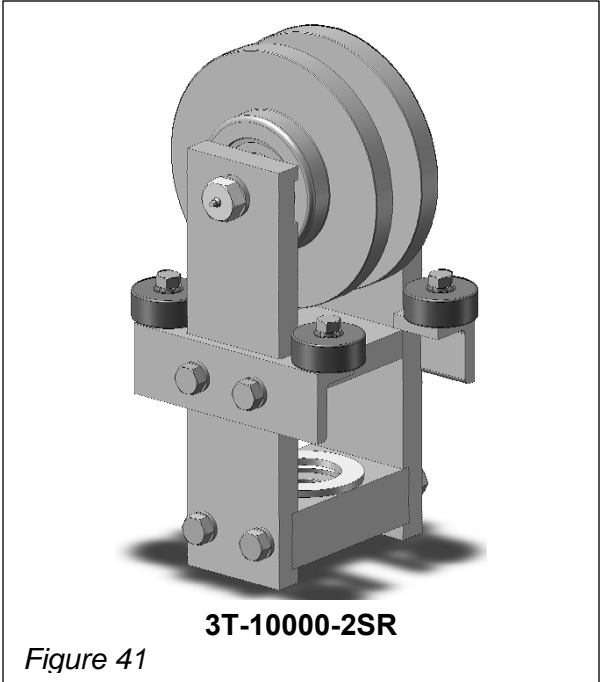

Figure 41

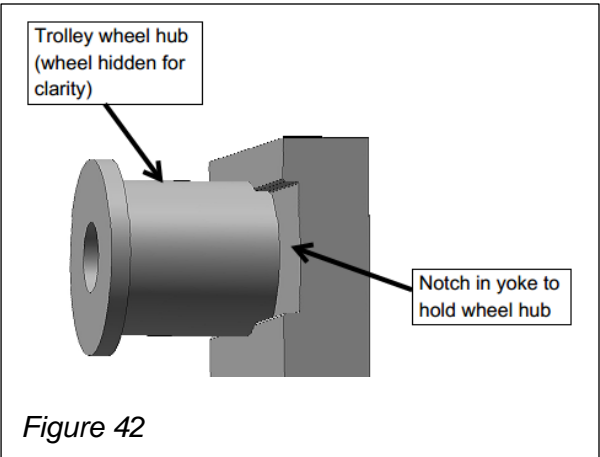

Figure 42

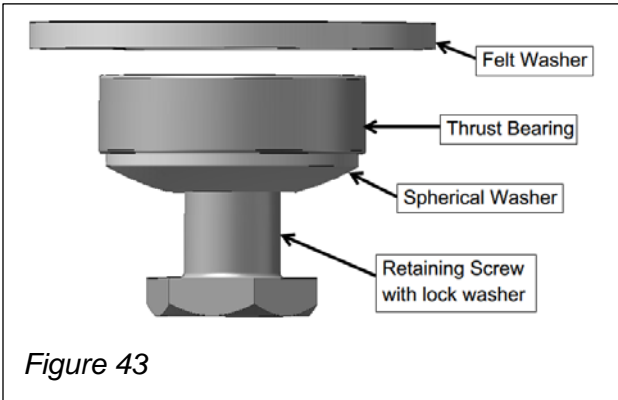

Figure 43

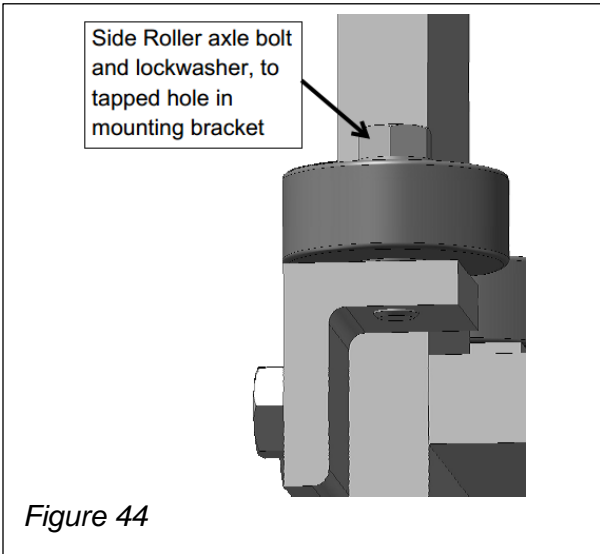

Figure 44

## 325 Series Trolleys

### Lubrication

#### General Lubrication Information

1. Trolley Wheels
  - Trolley wheels with grease fittings in end of axles are packed with grease when assembled. Relubricate after use with multi-purpose lithium grease until a light film of grease appears around wheel axle. Wipe clean after greasing.
  - Trolley wheels (special order) with sealed bearings have no grease fittings and require no further lubrication.
  - Trolley wheels with oil ports instead of grease fittings have only light oil on them from our bearing supplier. Use additional light machine oil sparingly, only as required to keep the trolley wheels turning freely. Do not use excess oil that could drip onto product. Coordinate with end user regarding their preferences for oil to use.
2. Spherical Washer
  - For trolleys with a thrust washer, at installation apply a light coat of EP (Extreme Pressure) grease to the spherical washer before assembling the trolley to the load bar.
3. Yoke Pockets
  - Though not required, it is acceptable to lubricate the inside of the pocket with a light coat of EP (Extreme Pressure) grease when assembling a yoke to a load bar or a fitting.
4. Swivel Bushing
  - Though not required, it is acceptable to lubricate the inside of the swivel bushing with a light coat of EP (Extreme Pressure) grease when assembling to a fitting.
5. Side Rollers
  - Standard side rollers are provided with sealed bearings and require no further lubrication.

#### Lubrication Frequency

There is no absolute definition for periodic relubrication of TC/American Crane trolleys. Each application must be evaluated on its own merits, including: service duty, operating speed, number of operations per shift, and operating environment.

Maintenance personnel should develop and maintain a record of all monthly inspections. Frequency of lubrication may be adjusted to match operational demands, based upon inspection reports.

#### Recommended Trolley Lubricants

(for standard industrial operating environments)

Trolley Wheels (if regreaseable)	Good grade multi-purpose lithium grease
Trolley Wheels (with oil port in axle)	Good grade light machine oil
Spherical Washer	Good grade "EP" grease
Yoke and Swivel Bushing Pockets	Good grade "EP" grease

Note: TC/American Crane does not normally make a 'brand name' recommendation for lubricants. Each customer may have a preference based upon many legitimate reasons. TC/A recommends to use a "good quality" lubricant and, when one is chosen, to not mix them.

**NOTE: before applying any lubricant to equipment that will be taken onto a customer's site, check with the customer for any preferences on brands or types (to maintain customer stock uniformity of products used and records maintenance).**

**NOTE: have Material Safety Data Sheet (MSDS) info available for any lubricants brought onto a work site.**

**NOTE: verify with customer that lubricants being used will not have an effect upon any production processes.**



**Fittings**

See Trolley Section of TC/American Crane Systems Catalog for more detail.

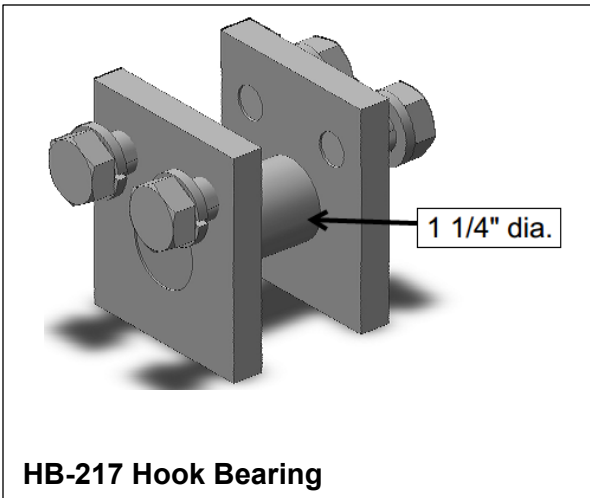
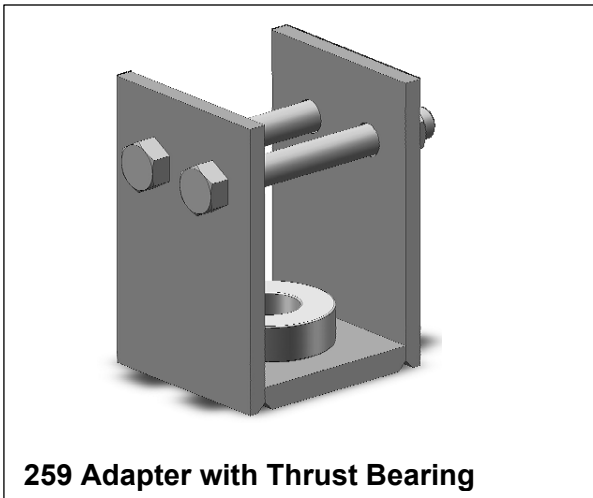
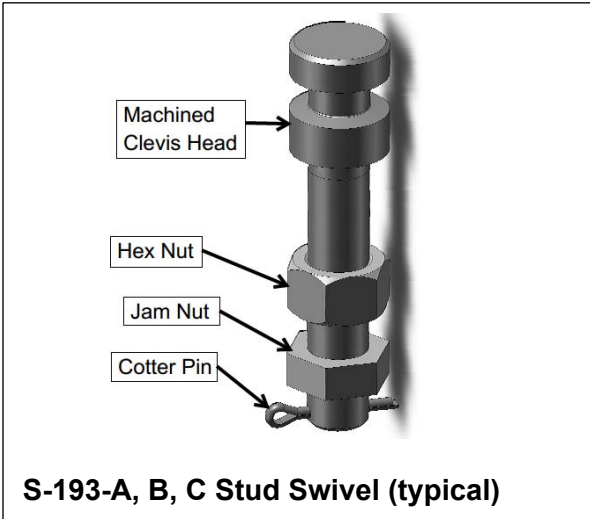
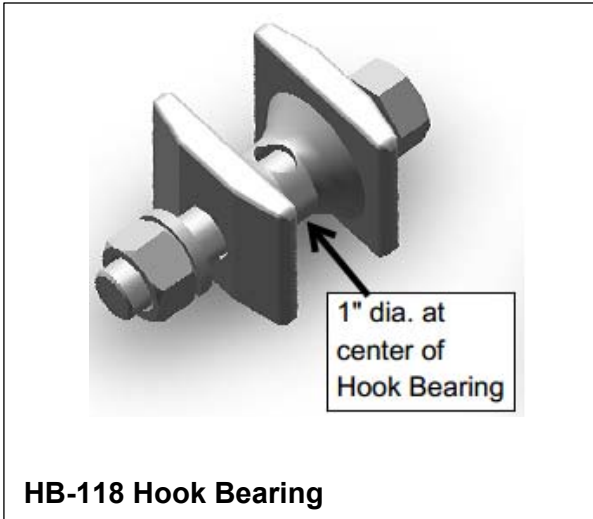
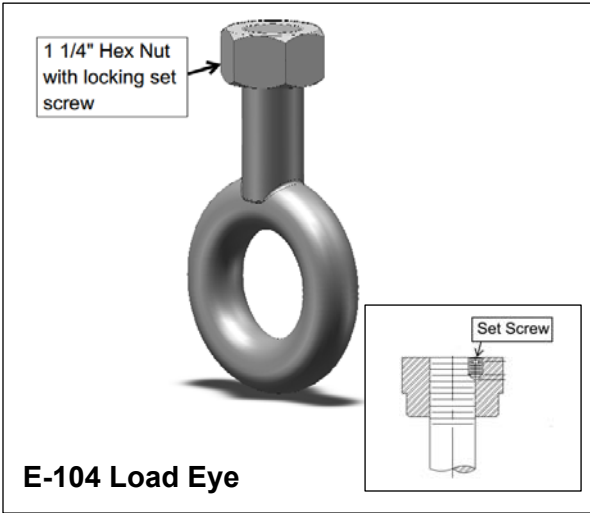
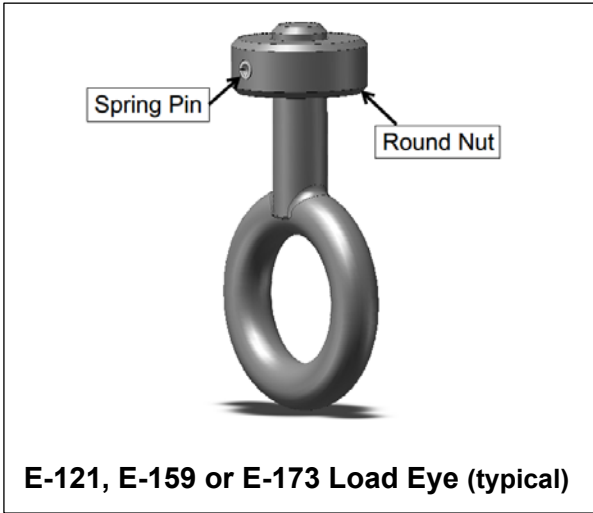

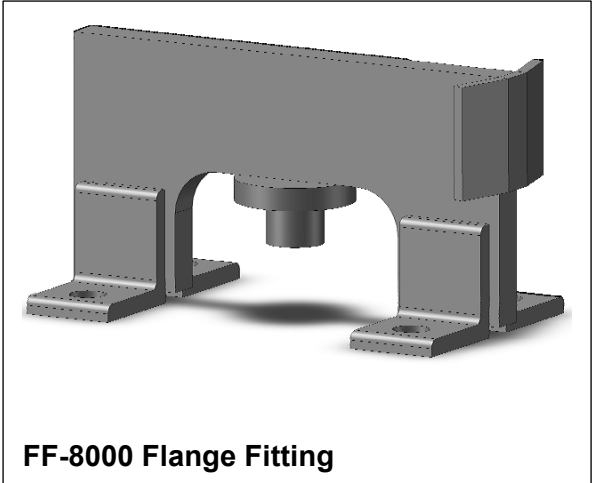
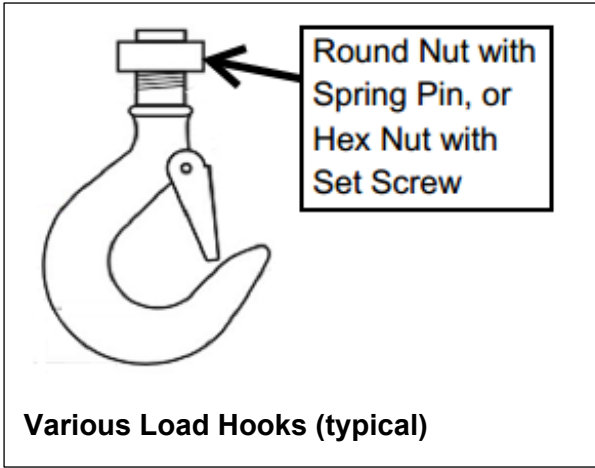
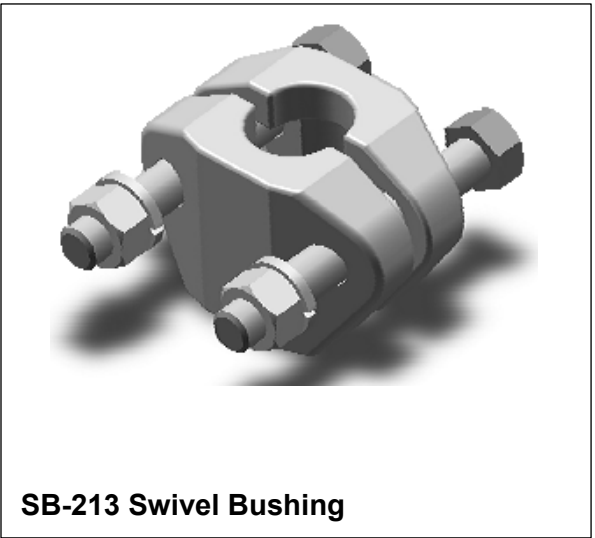
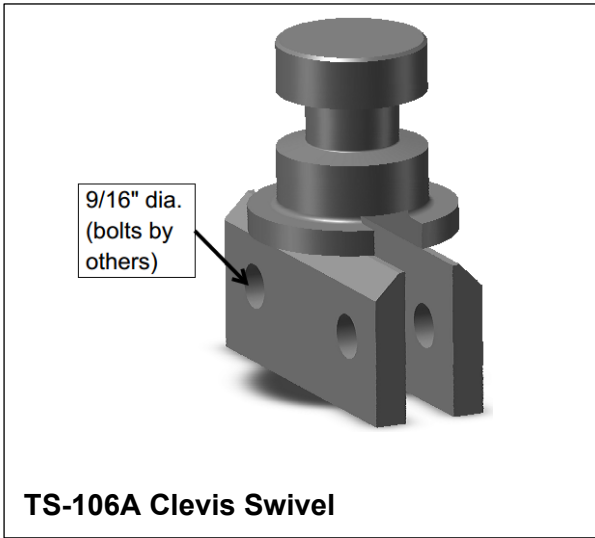
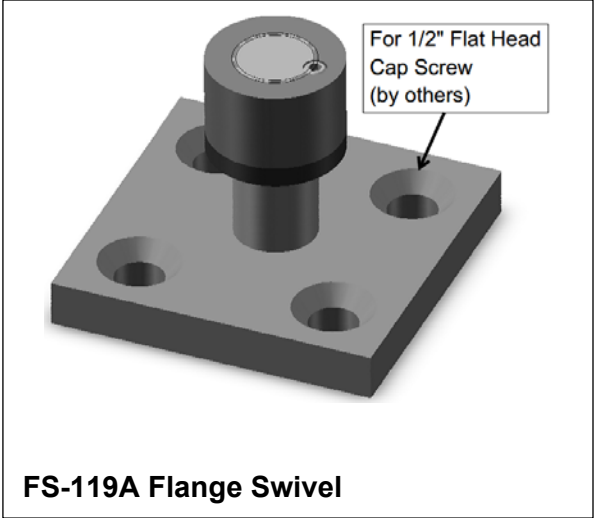
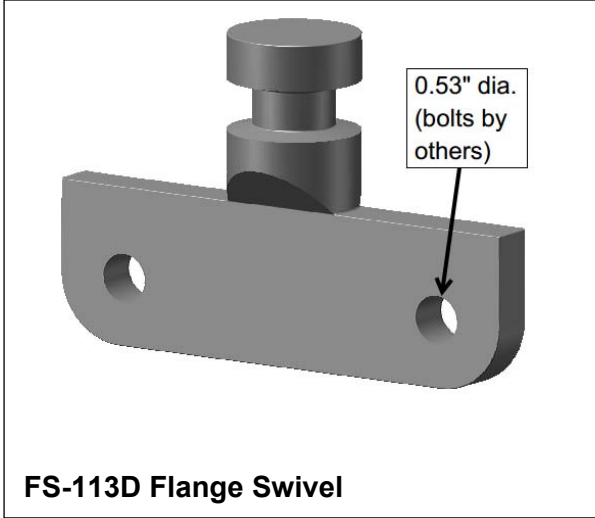

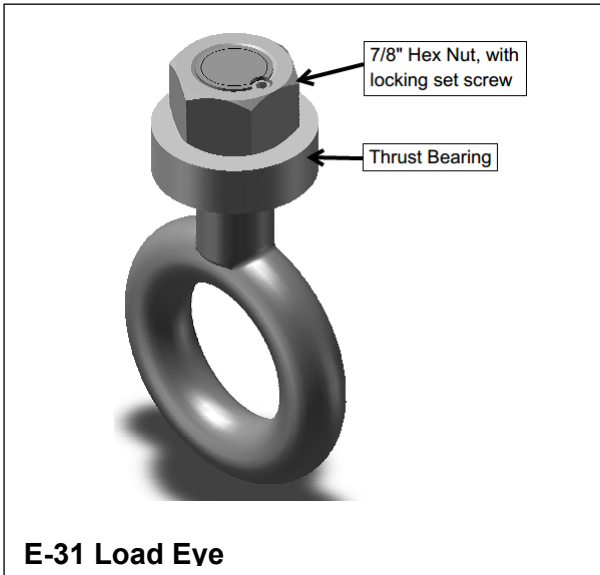
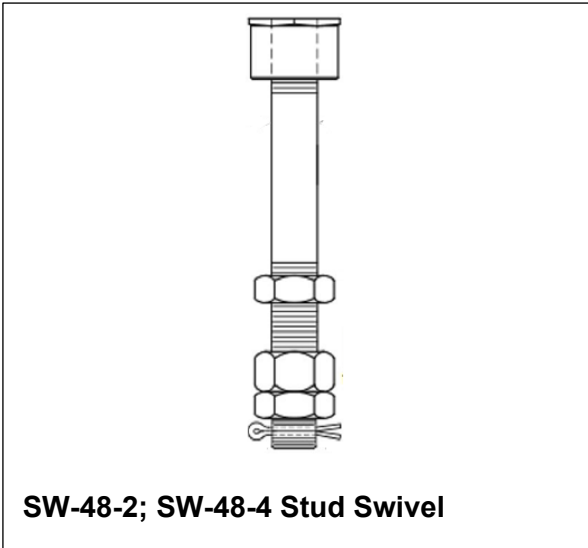

Contact the factory for other fitting options.