



CATÁLOGO DE PRODUCTOS CORPORATIVO
CORPORATE BRAND AND PRODUCT BOOK



Tecnología y seguridad

Technology and Security features

Aplicamos la última tecnología y los últimos materiales en nuestras grúas industriales, garantizando la máxima fiabilidad de nuestras grúas. Con más de 50 años de experiencia en el sector de la maquinaria de elevación, JASO Industrial Cranes es líder en soluciones de elevación en los procesos de fabricación más avanzados.

We use the latest technology in our industrial cranes, guaranteeing maximum reliability. With more than 50 years' experience in the lifting machinery sector, JASO Industrial Cranes is the leader in lifting solutions in the most advanced manufacturing processes.

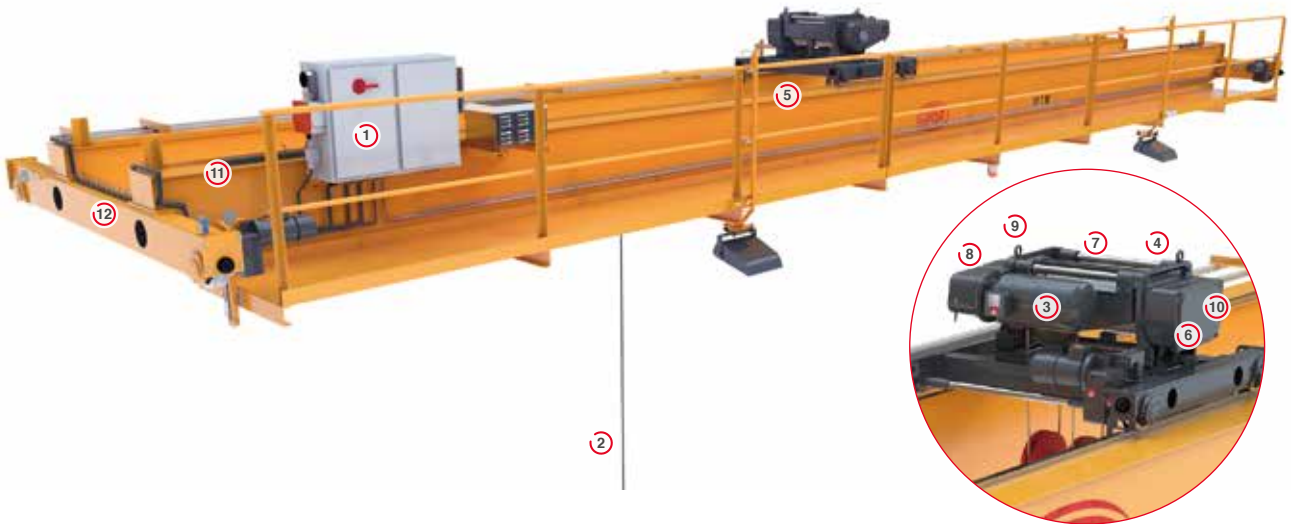

①

EQUIPO ELÉCTRICO

En un armario compacto y dimensionado, se incluye todo el aparellaje eléctrico incluido los variadores de frecuencia de fabricantes de alta calidad.

ELECTRONIC EQUIPMENT

All electrical control gear is located in a compact and sized cabinet, including its frequency converter made by high-quality manufacturers.

②

MANDO

A través de botonera colgante con pulsadores que accionan los contactores debidamente dimensionados. Opcionalmente, se puede realizar por radio control.

CONTROL

Using a push-button control with buttons that activate the duly sized contactors. This can also be carried out by radio control.

③

LIMITADOR DE CARGA

Cumpliendo con las directivas FEM y de seguridad de máquinas, se dispone mediante un dispositivo de célula en el eje de apoyo.

LOAD LIMITER

In compliance with the FEM and machine safety directives, it is provided by a cellular device in the supporting axle.

④

GUÍA CABLE

De fundición nodular resistente a la rotura y desgaste. Consta de dos piezas facilitando el montaje de la misma y mediante su muelle, mantiene tenso el cable durante las operaciones de elevación.

CABLE GUIDE

Nodular casting, breakage and wear resistant. It consists of two pieces, which makes it easy to assemble. It maintains the tension in the cable during lifting operations using its spring.



5

APAREJO Y GANCHO

De acero aleado forjado, con materiales de alta resistencia, suspendido de una cruceta girando sobre un rodamiento axial.

6

FINAL DE CARRERA

De tipo de husillo, limita el movimiento del gancho en las posiciones extremas. Dispone de un segundo contacto de seguridad actuando sobre el contacto general.

7

TAMBOR

De tubo de acero laminado totalmente mecanizado y ranurado siguiendo las normas vigentes de FEM y CMAA. Bajo pedido se puede adaptar con versiones de uno o dos roscas.

8

MOTOR DE ELEVACIÓN

Motor de rotor en cortocircuito especialmente diseñado para su utilización en mecanismos de elevación en configuraciones de doble devanado o variador de frecuencia. Incluye protecciones IP-55 y bajo pedido se pueden suministrar con otras configuraciones.

9

FRENO

De corriente continua incorporado al motor. De accionamiento instantáneo en caso de cese corriente.

10

REDUCTOR DE ELEVACIÓN

Formado por engranaje helicoidales montado sobre rodamientos de primera calidad, girando en baño de aceite en caja robusta y herméticamente cerrada.

11

VIGAS

Vigas de tipo cajón construidas en acero laminado y soldado. Llevan diafragmas y rigidizadores interiores para asegurar la estabilidad de almas y platabandas.

12

TESTEROS

Construidos en forma de tubular en acero laminado. Unidos a las vigas principales por medio de atornillamiento de alta resistencia.

LOAD BLOCK AND HOOK

Made of forged alloyed steel, suspended from a cross piece rotating on an axial bearing.

LIMIT SWITCH

Spindle limit switch that limits hook movement in extreme positions. It has a second safety contact which acts on the general contact.

DRUM

Made of a completely mechanised, slotted, laminated steel tube, as per the current FEM and CMAA regulations. One- or two-bolt versions may be adapted upon request.

LIFTING MOTOR

Motor with a short-circuit rotor specially designed for its use in lifting mechanisms with double winding figurations or with a frequency converter. It includes IP-55 protection. Other configurations can be supplied on request.

BRAKE

Direct power brake incorporated in the motor. Instant action, in case of power failure.

ELEVATION REDUCING GEAR

Formed by a helical gear mounted on bearings, rotating in an oil bath in a stable, hermetically sealed cabinet.

GIRDERS

Box girders constructed using welded laminated steel. They contain interior stiffeners and diaphragms to ensure the stability of the core and the cover plate.

ENDCARRIAGES

Constructed in tubular format using laminated steel. Joint to the main girders through high quality screw attachment.



Criterio de selección de un polipasto

Criteria for choosing a hoist

Forma de elección

El modelo adecuado de polipasto es determinado según norma FEM por el tipo de carga, tiempo de funcionamiento diario, capacidad de carga a elevar y disposición del cable.

Para el promedio de funcionamiento diario se elige un valor aproximado o bien se calcula el mismo de la manera siguiente:

Selection method

The correct hoist model is determined by FEM regulations in relation to the type of load to handle, average operation time, load lifting capacity and cable layout.

Either an approximate value is chosen to calculate daily operation time averages, or it can be calculated as follows:

TIEMPO DE FUNCIONAMIENTO DIARIO // DAILY OPERATION TIME

$$2x \frac{\text{recorrido medio de gancho (m) x ciclos por hora x tiempo de servicio por día (h)}}{\text{average lifting height (m) x cycles per hour x service time per day (h)}}$$

$$60x \frac{\text{velocidad de elevación (mpm)}}{\text{lifting speed (mpm)}}$$

Ejemplo

Para una carga de tipo ligero y un promedio de marcha de 8 horas, la tabla nos da un polipasto del grupo de mecanismos M5 según FEM. En la tabla vemos que para una carga a elevar de 10.000 kg, en el grupo citado anteriormente y con 4/1 ramales, le correspondería el polipasto eléctrico CX100.

Example

For a light load and running average of 8 hours, the table indicates a hoist of classification group M5, according to FEM. Thus, to lift a load of 10.000 kg in the previously mentioned group and considering a 4/1 fall configuration, the corresponding hoist is CX-100 type.

Tipo de carga Type of load	10.000 kg
Velocidad de elevación Lifting speed	5 mpm Ligero // Light
Nº de ramales Nr. of falls	4/1
Recorrido medio de gancho Average lifting height	6 m
Ciclos de trabajo por hora Working cycles per hour	25
Tiempo de servicio por día Service time per day	8h

Tiempo de funcionamiento diario
Daily operation time

$$\frac{2x 6 x 25 x 8}{60x 5} = 8 \text{ h.}$$



ESTADO DE SOLICITACION TYPE OF SERVICE	
LIGERO LIGHT	
MEDIO MEDIUM	
PESADO HEAVY	
MUY PESADO VERY HEAVY	

TIEMPO MEDIO DE FUNCIONAMIENTO POR DÍA LABORABLE (HORAS) AVERAGE DAILY OPERATION TIME (HOURS)		
2 - 4	4 - 8	8 - 16
1 - 2	2 - 4	4 - 8
0,5 - 1	1 - 2	2 - 4
0,25 - 0,5	0,5 - 1	1 - 2

FEM 1987/ISO			
C.M.A.A.			
CAPACIDAD DE CARGA (KG) // LOAD CAPACITY			
			80.000
			63.000
		50.000	
10.000	20.000	40.000	
8.000	16.000	32.000	
6.300	12.500	25.000	
5.000	10.000	20.000	
4.000	8.000	16.000	
3.200	6.300	12.500	
2.500	5.000	10.000	←
2.000	4.000	8.000	
1.600	3.200	6.300	
1.250	2.500	5.000	
1.000	2.000	4.000	
800	1.600	3.200	
630	1.250	2.500	
500	1.000	2.000	
1/1	2/1	4/1	6/1 8/1
RAMALES DE CABLE // CABLE FALLS			

M4	M5	M6
"B"/"C"	"D"	"E"
EX800		
	EX630	
	EX500	
EX400		
	EX320	
		EX250
DX200		
	DX160	
CX125		DX125
	CX100	
BX63		CX80
	BX50	
		BX40
AX32		
	AX25	
		AX20

EQUIVALENCIAS ENTRE NORMAS STANDARDS EQUIVALENCE					
FEM1970 / DIN 15020	1Am	2m	3m	4m	5m
FEM 1987 / ISO	M4	M5	M6	M7*	M8
UNE 58112 - 1 :1991	M4	M5	M6	M7*	M8
C.M.A.A. ≈	"B"/"C"	"D"	"E"	"F"	-

Polipastos

Hoists



“ Gama de polipastos con capacidad de hasta 100 t.

Hoist product line with capacities of up to 100 t.



Con dos gamas de producto, Gama N con motor de elevación en dos velocidades y Gama V con variador de frecuencia en elevación, ofrecemos las mejores soluciones para su empresa en capacidades hasta 100 t en las diferentes configuraciones de grúas o plumas.

With two product ranges, 'N' Range with a two-speed lifting motor and 'V' Range with frequency converter, we offer the best solutions for your company with lifting capacities of up to 100 t in different crane and jib configurations.



Capacidad // Capacity
1 a / to 100 t



Luz // Span
1 a / to 30 m



Grupo de trabajo // Work Group
M4 a / to M6



Configuraciones Configurations

Existen distintos tipos de configuraciones para los polipastos.
There are different configuration types of hoists.

POLIPASTO APOYADO SUPPORTED HOIST

Con coronas y piñones fabricados con acero de cementación, conseguimos reductores de reducidas dimensiones y alto rendimiento. Es la perfecta solución para procesos auxiliares.

With gear wheels and pinions manufactured with case hardened steel, we achieve small high performance gears. The perfect solution for auxiliary processes.

POLIPASTO MONORRAÍL SINGLE GIRDER HOIST

Es la mejor opción para aquellas aplicaciones con espacio reducido. Consta de dos carros (motriz y auxiliar) y de dos ruedas que giran cada una sobre rodamientos asentados en las chapas debidamente mecanizadas y unidas por espárragos.

The best option for use in reduced spaces. It consists of two trolleys (motorized and auxiliary) with two wheels that turn on bearings attached to plates which are duly mechanized and joined by bolts.

POLIPASTO BIRRAÍL DOUBLE GIRDER HOIST

El polipasto perfecto para conseguir la mejor combinación de estabilidad, equilibrio y recorrido de gancho. Con un bastidor formado por dos testeros en forma de cajón tubular mecanizados después del ensamblaje para asegurar la perfecta alineación de las ruedas.

The perfect hoist to achieve a combination of stability, balance and lifting height. Made up of a frame formed by two end-carriages, mechanized after assembly, in order to ensure the perfect alignment of the wheels.

Apoyado // Supported



Monorraíl // Single-Girder



Altura Reducida // Low Headroom



Birraíl // Double-Girder



Gama **V** de polipastos (Variador de frecuencia en elevación) **V hoist** product range (Lifting frequency inverter)

Esta gama de polipastos incluye de serie variador en sobrevelocidad en el motor de elevación.

This range of hoists includes an over-speed inverter in the lifting motor as a standard.

- Variador en elevación y traslaciones - Suavidad en el arranque y más silencioso. Transfer and Lifting Variator - Smoother and quieter starts.
- Control Vectorial en lazo cerrado - Mayor seguridad y control del sistema. Closed Loop Vector Control - Safer with more system control.
- Frenos de continua en elevación y traslación - Menos desgaste. Continuous Lifting and Transfer Brakes - Less wear.
- Cable, rotura efectiva 220 kg/mm² - Mayor coeficiente de resistencia. Wire rope, effective rupture 220 kg/mm² - Greater resistance coefficient.
- Caja de conexiones en el propio polipasto, protección IP-55 - Mantenimiento más sencillo y mayor aislamiento. Hoist Junction Box with IP-55 protection - Simpler maintenance and better insulation.
- Velocidades regulables en elevación y traslación de 0 a velocidad nominal - Mayor versatilidad. Adjustable Lifting and Transfer Speeds, from 0 to a nominal velocity - Greater versatility.
- Encóder montado fuera del motor, siendo más fiable la lectura del variador. Encoder mounted outside the motor, making the reading of the variator more reliable.
- Solución eléctrica en multitensión - Versatilidad para funcionamiento en diferentes países sin necesidad de adaptación. Electric Multi Tension Solution - Versatility, so it doesn't have to be adapted to work in different countries.
- Polipasto más compacto y reducido en longitud un 36%, no sobresaliendo del bastidor del carro consiguiendo mejores acercamientos. A more compact hoist reduced in length by 36 %, thereby not overreaching the trolley frame and so ensuring closer links.



Birrail V // Double Girder V



Carro dos polipastos // Trolley with two hoists

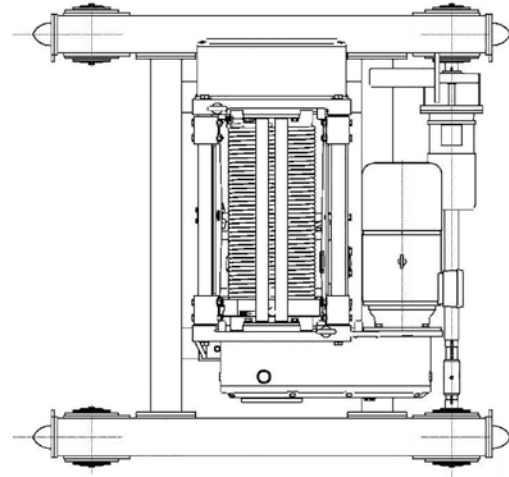
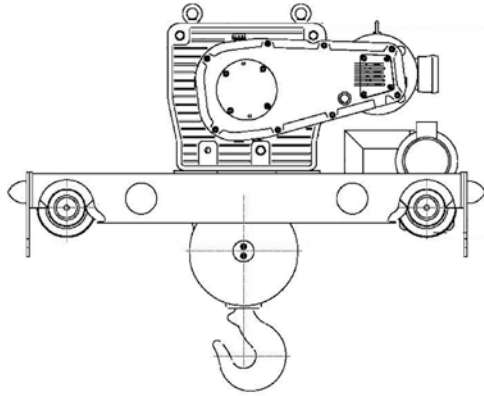

CARACTERÍSTICAS Y DATOS TÉCNICOS SERIE V
CHARACTERISTICS & TECHNICAL DATA V RANGE

CAPACIDAD CAPACITY	Tipo Type	Grupo Group	Velocidad Speed	Recorrido de gancho (m) Lifting height (m)				Cable Wire rope		Motor (50 hz) Motor (50 hz)
				H08	H12	H16	H20	Nº Ramales Nº falls	Ø (mm)	max Kw
1000	VA10H**21*7	M7	0 - 12	16	24			2 / 1	6,5	4,6
1250	VA12H**21*6	M6	0 - 12	16	24			2 / 1	6,5	4,6
1600	VA16H**21*5	M5	0 - 12	16	24			2 / 1	6,5	4,6
2000	VA20H**21*4	M4	0 - 12	16	24			2 / 1	6,5	4,6
2500	VA25H**41*6	M6	0 - 6	8	12			4 / 1	6,5	4,6
	VB25H**21*6	M6	0 - 12	16	24	32		2 / 1	9	9,4
3200	VA32H**41*5	M5	0 - 6	8	12			4 / 1	6,5	4,6
	VB32H**21*5	M5	0 - 12	16	24	32		2 / 1	9	9,4
4000	VA40H**41*4	M4	0 - 6	8	12	16		4 / 1	9	4,6
	VB40H**21*4	M4	0 - 12	16	24	32		2 / 1	9	9,4
5000	VB50H**41*6	M6	0 - 6	8	12	16		4 / 1	9	9,4
	VC50H**21*6	M6	0 - 12	16	24	32	40	2 / 1	12	18
6300	VB63H**41*5	M5	0 - 6	8	12	16		4 / 1	9	9,4
	VC63H**21*5	M5	0 - 12	16	24	32	40	2 / 1	12	18
7500	VB75H**41*4	M4	0 - 6	8	12	16		4 / 1	9	9,4
	VC75H**21*4	M4	0 - 12	16	24	32	40	2 / 1	12	18
8000	VB80H**41*4	M4	0 - 6	8	12	16		4 / 1	9	9,4
	VC80H**41*6	M6	0 - 6	8	12	16	20	4 / 1	12	18
10000	VC100H**41*6	M6	0 - 6	8	12	16	20	4 / 1	12	18
12500	VC125H**41*5	M5	0 - 6	8	12	16	20	4 / 1	12	18
15000	VC150H**41*4	M4	0 - 6	8	12	16	20	4 / 1	12	18

Para capacidades mayores consultar // For higher capacities please contact us
 Factor del motor: S4-30%, ED 400-87Hz // Service factor: S4-30%, ED 400-87Hz

Gama **N** de polipastos (motor de dos velocidades)

N hoist product range (two speed motor)

Nuestros polipastos de cable con motor de elevación en 2 velocidades, ofrecen una contrastada experiencia con miles de equipos instalados en los últimos años. Sus principales fortalezas son:

Our wire rope hoists with a two-speed lifting motor are supplied with the proven experience of thousands pieces of equipment installed in the last years. Its main strengths are:

- Motor freno de rotor en cortocircuito con doble devanado y protecciones IP-55.
Dual winding motor brake with a short circuit rotor and IP-55 protection.
- Freno electromagnético de accionamiento instantáneo por cese de corriente.
Instantaneously triggered electromagnetic brake in case of power failure.
- Reductor de elevación de diseño propio. Engranajes sobre rodamientos en baño de aceite continuo.
Elevation reducing gear of our own design comprised of gears on bearings in an oil bath.
- Tambor de tubo de acero laminado (normativa FEM).
Laminated steel drum, (FEM regulations).
- Guía Cable: De fundición nodular resistente a la rotura y al desgaste. Consta de dos piezas, facilitando el montaje de la misma.
Cable-Guide: Nodular casting, breakage and wear resistant. Consists of two pieces, which makes it easy to assemble.
- Limitador de Carga: Con micro interruptor de accionamiento mecánico cumpliendo con la directriz de seguridad de máquinas.
Load Limiter: With a snap action switch that complies with the machinery safety directive.
- Aparejo y gancho: De acero aleado forjado y suspendido de una cruceta del mismo material.
Load Block and Hook: Made from forged alloyed steel and suspended from a cross piece made from the same material.
- Final de Carrera: Accionado por el guía cable, limita el movimiento del gancho en las posiciones extremas.
Limit Switch: Operated by the cable-guide, it limits hook movement in extreme positions.



Birrañ N // Double Girder N

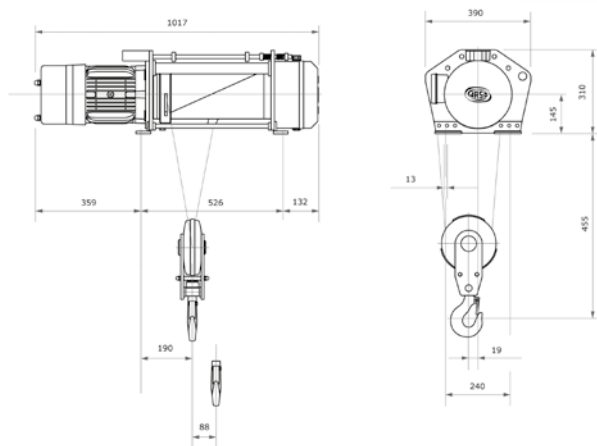



CARACTERÍSTICAS TÉCNICAS

TECHNICAL CHARACTERISTICS

Capacidad Capacity	Tipo Type	Nº Ramales Nº Falls	Ø Cable Wire rope	Potencia motor Motor power	Tamaño motor Motor size	Grupo FEM / FEM Group			Recorrido de gancho (m) Lifting height (m)							
						M4	M5	M6	H06	H10	H18	H22	H22	H26	H30	
KG			(mm)	(KW)		v (m/min)										
1000	AX10H*2/1S*	2/1	7	2,6 kw	112 M	12	10	8	12	20						
	AX10H*4/1S*	4/1	7	2,6 kw	112 M			6 ; 5 ; 4	6	10						
	AX10H*2/1L*	2/1	7	4 kw	132 M			12 ; 10	12	20						
1250	AX12H*2/1S*	2/1	7	2,6 kw	112 M	10	8		12	20						
	AX12H*4/1S*	4/1	7	2,6 kw	112 M			6 ; 5 ; 4	6	10						
	AX12H*2/1L*	2/1	7	4 kw	132 M		12 ; 10	8	12	20						
1600	BX12H*2/1S*	2/1	10	5 kw	132 M			12 ; 10 ; 8	12	20	28					
	AX16H*2/1S*	2/1	7	2,6 kw	112 M	8			12	20						
	AX16H*4/1S*	4/1	7	2,6 kw	112 M		6	5 ; 4	6	10						
2000	AX16H*2/1L*	2/1	7	4 kw	132 M	12	10 ; 8		12	20						
	BX16H*2/1S*	2/1	10	5 kw	132 M		12	10 ; 8	12	20	28					
	BX16H*2/1L*	2/1	10	7,5 kw	160 M			12	12	20	28					
2500	AX20H*4/1S*	4/1	7	2,6 kw	112 M	6	5	4	6	10						
	AX20H*2/1L*	2/1	7	4 kw	132 M	8			12	20						
	AX20H*4/1L*	4/1	7	4 kw	132 M			6 ; 5	6	10						
3200	BX20H*2/1S*	2/1	10	5 kw	132 M	12	10	8	12	20	28					
	BX20H*2/1L*	2/1	10	7,5 kw	160 M			12 ; 10	12	20	28					
	AX25H*4/1S*	4/1	7	2,6 kw	112 M	5	4		6	10						
4000	AX25H*4/1L*	4/1	7	4 kw	132 M		6	5 ; 4	6	10						
	BX25H*2/1S*	2/1	10	5 kw	132 M	10	8		12	20	28					
	BX25H*4/1S*	4/1	10	5 kw	132 M			6	6	10	14					
5000	BX25H*2/1L*	2/1	10	7,5 kw	160 M		12 ; 10		12	20	28					
	CX25H*2/1S*	2/1	13	10 kw	160 M			12 ; 10 ; 8	12	20	28	36	44			
	AX32H*4/1S*	4/1	7	2,6 kw	112 M	4			6	10						
6300	AX32H*4/1L*	4/1	7	4 kw	132 M	6	5 ; 4		6	10						
	BX32H*2/1S*	2/1	10	5 kw	132 M	8			12	20	28					
	BX32H*4/1S*	4/1	10	5 kw	132 M		6	5 ; 4	6	10	14					
8000	BX32H*2/1L*	2/1	10	7,5 kw	160 M	12 ; 10	8		12	20	28					
	BX32H*4/1L*	4/1	10	7,5 kw	160 M			6	6	10	14					
	CX32H*2/1S*	2/1	13	10 kw	160 M		12	10 ; 8	12	20	28	36	44			
10000	AX40H*4/1L*	4/1	7	4 kw	132 M	4			6	10						
	BX40H*4/1S*	4/1	10	5 kw	132 M		5	4	6	10	14					
	BX40H*2/1L*	2/1	10	7,5 kw	160 M	10 ; 8			12	20	28					
12500	BX40H*4/1L*	4/1	10	7,5 kw	160 M			6 ; 5	6	10	14					
	CX40H*2/1S*	2/1	13	10 kw	160 M	12	10	8	12	20	28	36	44			
	CX40H*2/1L*	2/1	13	15 kw	180 L			12 , 10	12	20	28	36	44			
16000	BX50H*4/1S*	4/1	10	5 kw	132 M	5	4		6	10	14					
	BX50H*4/1L*	4/1	10	7,5 kw	160 M		6 ; 5		6	10	14					
	CX50H*2/1S*	2/1	13	10 kw	160 M	10	8		12	20	28	36	44			
20000	CX50H*4/1S*	4/1	13	10 kw	160 M			6 ; 5 ; 4	6	10	14	18	22			
	CX50H*2/1L*	2/1	13	15 kw	180 L		12 ; 10		8	12	20	28	36	44		
	DX50H*2/1L*	2/1	16	22,5 kw	200 L			12 ; 10	12	20	28	36	44	52		
25000	BX63H*4/1S*	4/1	10	5 kw	132 M	4			6	10	14					
	BX63H*4/1L*	4/1	10	7,5 kw	160 M	6	5 ; 4		6	10	14					
	CX63H*2/1S*	2/1	13	10 kw	160 M	8			12	20	28	36	44			
32000	CX63H*4/1S*	4/1	13	10 kw	160 M		6	5 ; 4	6	10	14	18	22			
	CX63H*2/1L*	2/1	13	15 kw	180 L	12	10 ; 8		12	20	28	36	44			
	DX63H*2/1S*	2/1	16	15 kw	180 M			8	12	20	28	36	44	52		
40000	DX63H*2/1L*	2/1	16	22,5 kw	200 L			12 ; 10	12	20	28	36	44	52		
	BX80H*4/1L*	4/1	10	7,5 kw	160 M	5 ; 4			6	10	14					
	CX80H*4/1S*	4/1	13	10 kw	160 M	6	5	4	6	10	14	18	22			
50000	CX80H*2/1L*	2/1	13	15 kw	180 L	8			12	20	28	36	44			
	CX80H*4/1L*	4/1	13	15 kw	180 L			6 ; 5	6	10	14	18	22			
	DX80H*2/1S*	2/1	16	15 kw	180 M	10	8		12	20	28	36	44	52		
63000	DX80H*2/1L*	2/1	16	22,5 kw	200 L		12 ; 10	8	12	20	28	36	44	52		
	CX100H*4/1S*	4/1	13	10 kw	160 M	5	4		6	10	14	18	22			
	CX100H*4/1L*	4/1	13	15 kw	180 L		6 ; 5	4	6	10	14	18	22			
80000	DX100H*2/1S*	2/1	16	15 kw	180 M	8			12	20	28	36	44	52		
	DX100H*4/1S*	4/1	16	15 kw	180 M			5	6	10	14	18	22	26		
	DX100H*2/1L*	2/1	16	22,5 kw	200 L	12 ; 10	8		12	20	28	36	44	52		
100000	DX100H*4/1L*	4/1	16	22,5 kw	200 L			6	6	10	14	18	22	26		
	EX100H*2/1S*	2/1	20	22,5 kw	200 L			6	6	10	14	18	22	26		
	EX100H*2/1L*	2/1	20	31 kw	200 XL			10 ; 8	20	28	36	44	52	60		
125000	CX125H*4/1S*	4/1	13	10 kw	160 M	4			6	10	14	18	22			
	CX125H*4/1L*	4/1	13	15 kw	180 L	6	5 ; 4		6	10	14	18	22			
	DX125H*4/1S*	4/1	16	15 kw	180 M			4	6	10	14	18	22	26		
160000	DX125H*4/1L*	4/1	16	22,5 kw	200 L			6 ; 5	6	10	14	18	22	26		
	EX125H*2/1S*	2/1	20	22,5 kw	200 L	8	6		20	28	36	44	52	60		
	EX125H*2/1L*	2/1	20	31 kw	200 XL		10 ; 8	6	20	28	36	44	52	60		
200000	CX160H*4/1L*	4/1	13	15 kw	180 L	4			6	10	14	18	22			
	DX160H*4/1S*	4/1	16	15 kw	180 M	5	4		6	10	14	18	22	26		
	DX160H*4/1L*	4/1	16	22,5 kw	200 L		6 ; 5	4	6	10	14	18	22	26		
250000	EX160H*2/1S*	2/1	20	22,5 kw	200 L		6		20	28	36	44	52	60		
	EX160H*2/1L*	2/1	20	31 kw	200 XL	10	8		20	28	36	44	52	60		
	EX160H*4/1L*	4/1	20	31 kw	200 XL			5 ; 4 ; 3	6	10	14	18	22	26	30	
320000	DX200H*4/1S*	4/1	16	15 kw	180 M	4			6	10	14	18	22	26		
	DX200H*4/1L*	4/1	16	22,5 kw	200 L	6 ; 5	4		6	10	14	18	22	26		
	EX200H*2/1S*	2/1	20	22,5 kw	200 L	6			20	28	36	44	52	60		
400000	EX200H*4/1S*	4/1	20	22,5 kw	200 L			3	10	14	18	22	26	30		
	EX200H*2/1L*	2/1	20	31 kw	200 XL	8 ; 6			20	28	36	44	52	60		
	EX200H*4/1L*	4/1	20	31 kw	200 XL			5 ; 4	10	14	18	22	26	30		
500000	EX250H*4/1S*	4/1	20	22,5 kw	200 L	4			3	10	14	18	22	26	30	
	EX250H*4/1L*	4/1	20	31 kw	200 XL		5	4	10	14	18	22	26	30		
	EX320H*4/1S*	4/1	20	22,5 kw	200 L		3		10	14	18	22	26	30		
630000	EX320H*4/1L*	4/1	20	31 kw	200 XL	5	4		10	14	18	22	26	30		
	EX320H*6/1S*	6/1	20	22,5 kw	200 L	3,33	2,6	2	6,67	9,33	12	14,67	17,33	20		
	EX320H*6/1L*	6/1	20	31 kw	200 XL		3,33	2,6	6,67	9,33	12	14,67	17,33	20		



Testero

End carriage

TESTEROS Y MECANISMOS DE TRASLACIÓN

Cada Testero está equipado con:

- Un motor - reductor con engranajes helicoidales en constante baño de aceite girando sobre rodamientos.
- Las coronas y piñones están fabricados con acero de cementación consiguiendo reductores de reducidas dimensiones y alto rendimiento.
- Dos ruedas que giran sobre rodamientos, una de las cuales es accionada en ataque directo por el eje de salida de reductor.

ESTRUCTURA

Construidos de perfil estructural o en forma de cajón soldado y mecanizados después del ensamblaje para asegurar la perfecta alineación de las ruedas. Dos topes de caucho van montados en los extremos.

END CARRIAGES AND TRAVELLING GEARS

Each end-carriage is composed of:

- A Gearmotor with helical gears in constant oil bath, rotating on bearings
- The gear wheels and pinions are manufactured with casehardened steel, creating a small, high performance gearbox.
- Two wheels, rotating on bearings, one of them activated by direct-driving from the gearbox output shaft.

STRUCTURE

Built as a structural section or box-shaped and machined after assembly, in order to ensure a perfect alignment of the wheels. Two rubber buffers are fitted to each end.

CARGAS MEDIAS ADMISIBLES POR RUEDA. S/NORMAS FEM 1987, GRUPO M4 (KG)

AVERAGE WORKING LOADS PER WHEEL, PER FEM 1987, GROUP M4 (KG)

Ø (mm)	Ancho cuadradillo mm Width square-bar mm	Reacción máxima kg. Maximun reaction kg.
125	40	4295
160	40	5425
200	40	7100
250	40	8945
315	40	11650
400	50	19570
500	50	24680
630	60	50325



TABLA DE DIMENSIONES

DIMENSIONS

TIPO TYPE	Rueda Wheel	A	B	C	D	E	F	G	H	I	LR	S	J	K	M
	Ø mm	mm	mm	mm	mm	mm	mm	mm	mm	mm	mm	mm	mm	mm	mm
160170	160	617	250	14	335	105	135	190	290	230	1700	2160	40	30	78
160200	160	617 / 654	250	14 / 4	335 / 382	105	135	190	290	230	2000	2460	40	30	78
16250	160	617 / 654	250	14 / 4	335 / 382	105	135	190	290	230	2500	2960	40	30	78
160325	160	617 / 654	250	14 / 4	335 / 382	105	135	190	290	230	3250	3710	40	30	78
160400	160	654	250	4	382	105	135	190	290	230	4000	4460	40	30	78
160450	160	654	250	4	382	105	135	190	290	230	4500	4960	40	30	78
200170	200	679	275	24	402	127	155	225	325	260	1700	2220	40	30	93
200200	200	679	275	24	402	127	155	225	325	260	2000	2520	40	30	93
200250	200	679	275	24	402	127	155	225	325	260	2500	3020	40	30	93
200325	200	679	275	24	402	127	155	225	325	260	3250	3770	40	30	93
200400	200	679	275	24	402	127	155	225	325	260	4000	4520	40	30	93
200450	200	679	275	24	402	127	155	225	325	260	4500	5020	40	30	93
250170	250	679	275	49	426	140	180	243	380	285	1700	2270	40	30	103
250200	250	679	275	49	426	140	180	243	380	285	2000	2570	40	30	103
250250	250	679	275	49	426	140	180	243	380	285	2500	3070	40	30	103
250325	250	679	275	49	426	140	180	243	380	285	3250	3820	40	30	103
250400	250	679	275	49	426	140	180	243	380	285	4000	4570	40	30	103
250450	250	679	340	49	426	140	180	243	380	285	4500	5070	40	30	103
315170	315	770	340	60	491	164	227,5	295	437,5	330	1700	2360	40	30	125,5
315200	315	770	340	60	491	164	227,5	295	437,5	330	2000	2660	40	30	125,5
315250	315	770	340	60	491	164	227,5	295	437,5	330	2500	3160	40	30	125,5
315325	315	770	340	60	491	164	227,5	295	437,5	330	3250	3910	40	30	125,5
315400	315	770	340	60	491	164	227,5	295	437,5	330	4000	4660	40	30	125,5
315450	315	770	340	60	491	164	227,5	295	437,5	330	4500	5160	40	30	125,5
400325	400	782	352	104	534	176	285	325	515	375	3250	4000	50	30	138
400400	400	782	352	104	534	176	285	325	515	375	4000	4750	50	30	138
400450	400	782	352	104	534	176	285	325	515	375	4500	5250	50	30	138
500400	500	942	407	118	677	195	375	359	645	440	4000	4880	50	30	155
500450	500	942	407	118	677	195	375	359	645	440	4500	5380	50	30	155
500500	500	942	407	118	677	195	375	359	645	440	5000	5880	50	30	155
630400	630	1017	482	183	742	210	530	430	685	470	4000	4940	60	40	225
630500	630	1017	482	183	742	210	530	430	685	470	5000	5940	60	40	225
630550	630	1017	482	183	742	210	530	430	685	470	5500	6440	60 / 80	40	225
630600	630	1017	482	183	742	210	530	430	685	470	6000	6940	60	40	225

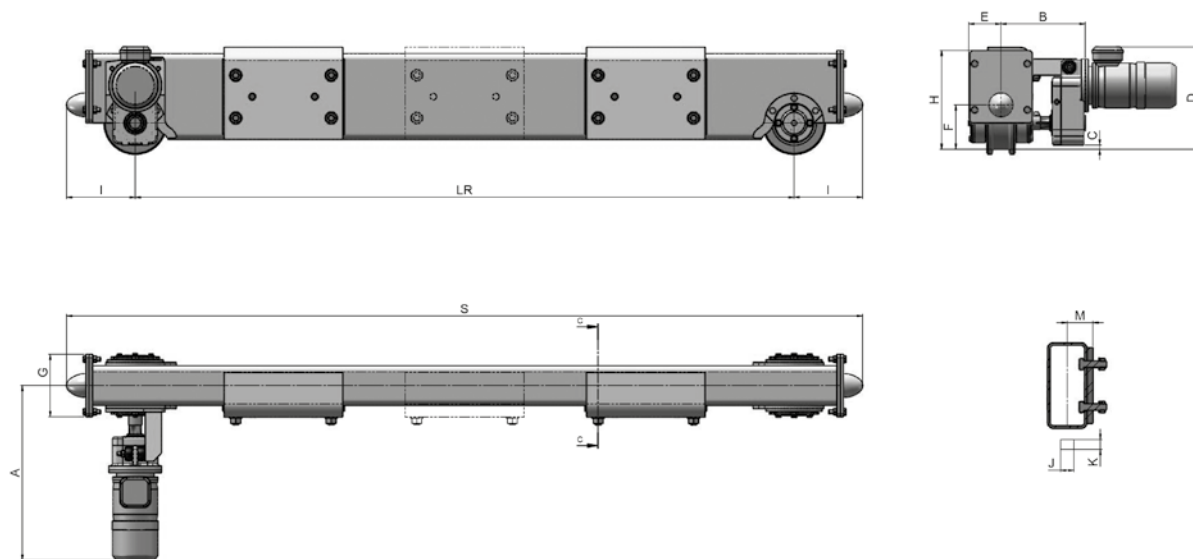