

Drivetractors

DANGER

Lifting Operations

Installation of equipment such as TC/American Crane's Drivetractors requires performing overhead lifting operations. Proper lifting procedures involve training, skills and experience beyond the scope of this document. Workplace supervisors are responsible to assure that all persons under their supervision are properly trained, properly equipped, and are following safety practices appropriate for the lifting operation being employed.

DANGER

Overhead Mechanical Assembly

Persons performing installation and assembly of overhead equipment must use caution while lifting, assembling and adjusting components. These operations are frequently conducted from manlifts or platforms that require specific knowledge, training and operation skills beyond the scope of this document.

Access to the floor below the work area must be restricted to reduce the potential of personnel injury due to falling objects.

Workplace supervisors are responsible to assure that all persons under their supervision are properly trained, properly equipped, and are following appropriate safety practices.

DANGER

Electrical Equipment Installation, Service and Maintenance

Persons performing installation, service or maintenance activities on, near, or with equipment that is electrically powered are exposed to electrical hazards that could result in serious injury or death if proper precautions are not followed. Before performing such work, disconnect the electrical power source for the system at the disconnect device and lock it out, following appropriate Lockout/Tagout (LOTO) procedures, to prevent electric power from being applied while work is being performed.

All persons must use safe work practices appropriate to the electrical system, and follow all workplace procedures and policies. This requires specific knowledge, equipment and training beyond the scope of this document. Workplace supervisors are responsible to assure that all persons under their supervision are properly trained, properly equipped, and are following appropriate safety practices.

Index

<u>Item</u>	<u>Page</u>
A. General Safety Cautions	1
B. Drivetractor Model Numbers and Descriptions	3
C. Drivetractors vs. Motorized Trolleys	4
D. General Installation Instructions	
E. Before Beginning Installation	5
F. Installing Drivetractor on Rail	5
G. Drive Tractor Trolleys	5
H. Connection to Hoist or Carrier	6
I. Initial Start-Up	6
J. Drivetractor Models	
K. Hand Chain Drivetractors	
L. 2D-231, 3D-231	7
M. 3D-631	8
N. Motorized Drivetractors	
O. 2D-4000, 2D-4000-SR, 3D-4000, 3D-4000-SR	9
P. 2D-2256-SR, 3D-6256-SR, 4D-2256-SR	10
Q. 3D28-300	11
R. 3D-622, 4D-22	12
S. 3D-630, 4D-30	13
T. Lubrication	
U. General Lubrication Information	14
V. Lubrication Frequency	15
W. Recommended Lubricants	15
X. Service of 3D28-300 Gearbox	15, 16
Y. Drive Tire Adjustment	16
Z. Drive Tire Pressure Adjustment Procedure	16, 17
AA. Drivetractor Balancing	17
BB. Options	17
CC. Roller Chain Drive Adjustment and Maintenance	18 - 22

Drivetractors

TC/American Crane offers several models of Drivetractors. Selection of the appropriate model depends upon the load to be pulled, speeds required and service duty class.

Drivetractor Model Numbers:

- The first character of the Drivetractor Model Numbers indicates the rail size on which the tractor operates:
 - 2 = 200 Series Rail
 - 3 = 325 Series Rail
 - 4 = 400 Series Rail.
- The second character, "D," identifies the product as a "Drivetractor."
- The intermediate characters do not have a uniform significant value or representation.
- The last characters, "SR," if present, indicate that the trolleys provided have "side rollers."
- Tractors of the same model but used on different rail series differ only in the trolleys used.

TC/American Crane Drivetractors (sometimes referred to as tractors, monotractors, monorail tractors, tractor drives, tugs, hoist tuggers or pullers) are equipped with a drive tire that contacts the underside of the patented track rail for positive traction. TC/American Crane Drivetractors may use either rubber or polyurethane tires, depending upon the model, and the tire diameter varies with the models. Drive tire pressure against the rail is adjusted at the connection of the trolley stud swivels to the drivetractor frame. Stud swivels may be rigid or spring loaded. See the model illustrations and descriptions on Pages 7, 8 and 9 for more information.

Motorized drivetractors may be electric or air motor powered. For light duty or short distance moves, hand chain powered drivetractors are an economical option.

These general Installation Instructions are for the following current TC/American Crane models:

Hand Chain Drivetractors	Models 2D-231, 3D-231 and 4D231 Models 3D-631 and 4D31
Motorized Drivetractors	Models 2D-4000, 2D-4000-SR, 3D-4000 and 3D-4000-SR Models 2D-2256-SR, 3D-6256-SR and 4D2256-SR Model 3D-28-300 Models 3D-622 and 4D-22 Models 3D-630 and 4D-30

NOTE: See the appropriate section(s) of these instructions for assembly, installation and maintenance details specific to your drivetractor model.

NOTE: For a specific parts breakdown of the drivetractor provided with an order, see the drawings provided with that shipment.

Drivetractors vs. Motorized Trolleys

Drivetractors differ from Motorized Trolleys in design, construction and application.

Drivetractor:

- may be used independently or separately from a hoist carrier or other trolleys,
- develops tractive force from pressure of drive tire against bottom of rail,
- pulls a load through a mechanical connection (drawbar) to the carrier,
- tractive effort is consistent, regardless of actual load.

Motorized Trolley:

- must be used in conjunction with a crane end truck or as part of a hoist carrier,
- load bar of the crane or hoist carrier is carried by the Motorized Trolley,
- weight of the crane or hoist carrier provides a load on the trolley wheels and thus develops traction,
- tractive effort will vary with the actual load.

Drivetractors and Motorized Trolleys are both effective components of a drive system for either monorails or cranes. The choice of one versus the other must be made with consideration of travel speeds, environmental conditions (is the rail likely to have moisture on it, resulting in a slippery tread surface), switches, curve radius, end approach required, etc.

General Installation Instructions

Before beginning the installation:

- When shipment is received, remove all shipping materials and check all parts for damage. Repair and/or replace as necessary.
- Check packing lists against materials received and identify all parts.
- Gather all equipment drawings and associated manuals (motor, reducer, brake, electrical components, etc.) and keep in a secure location for reference during installation and start-up, and to give to end user for future reference.
- Turn trolley wheels, and guide rollers if provided, by hand to check for possible damage in shipment. Check for rough bearings, loose bearings and axles.
- Check drive wheel and all components of drive system for condition. Check roller chain sprockets and chain for alignment and security. See *Roller Chain Drive Adjustment and Maintenance* in these Installation Instructions.
- Check exterior of electrical enclosure (if provided) for condition. Check integrity of enclosure latch mechanism.
- Check electrical panel, components and wiring (if provided) for condition. Check that all wires are marked and securely terminated.
- Check electrical collectors (if provided) for condition and proper operation. Check collector wiring for routing and security.
- Check assembly of drivetractor with respect to related equipment as shown on drawing. Make sure that drivetractor or hoist is not turned end for end.
- Check lubrication of regreaseable items and check oil level in gearboxes. See *Lubrication* in these Installation Instructions.

Installing Drivetractor on rail:

- Before raising drivetractor into place, loosen tire adjustment to provide clearance for rail between trolley wheels and tire. See *Drive Tire Pressure Adjustment* in these Installation Instructions.
- Use extreme caution when lifting drivetractor and other equipment into place.
- If possible, thread the assembled drivetractor onto the rail at any open end (remove end stop). If there is no open end, or if obstructions or other barriers prevent access to an open end, you may be able to bring the drivetractor up onto the rail by removing trolley wheels from the yoke, or by disassembling the trolleys. Reinstall/reassemble when in position. See Drivetractor Trolley descriptions below.

Drivetractor Trolleys: see the TC/American Crane catalog or the drawings provided with the equipment to determine the type of trolley on the drivetractor.

2T-2000 and 3T-2000 Trolleys have wheels with axles that are integral to the wheel assembly and cannot be removed. Removing a wheel and axle requires sliding the wheel and axle assembly inboard far enough to get the axle clear of the yoke. However, when the yoke straddles the rail, there is not enough clearance (between the arms of the yoke and the web of the rail) to reinstall the wheel! However, these trolley yokes are made from halves that are bolted together, so disassembly of the trolley is an option. Clamping bolts are provided with nuts and lock washers. To reassemble, tighten nuts until lock washers are flattened.

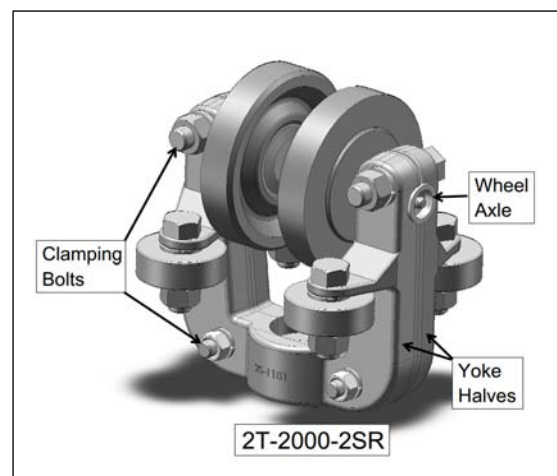

3T-6200 Trolleys are easily installed onto the rail by removing the trolley wheels if the trolley cannot be installed on an open end of rail. Wheels on these trolleys have “screw-in” axle bolts that thread into a hub in the wheel. To reinstall, tighten the axle bolt until a lock washer under the head is flattened.

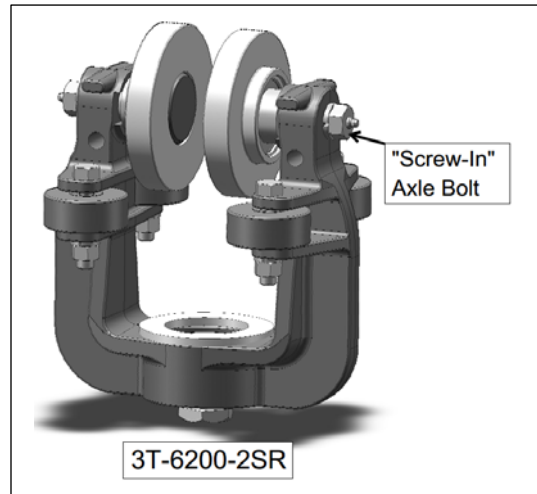

4T-4100-2SR Trolleys are used on 400 Series Drivetractors. These trolleys have wheels with integral axles, but the yokes are single piece. These trolleys must be installed at an open end of the rail.

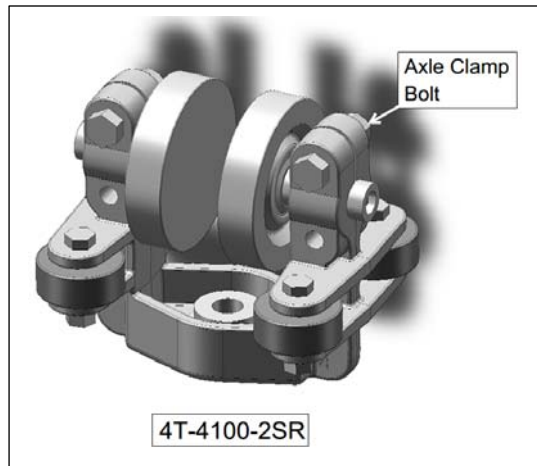

Connection to Hoist or Carrier:

- Connect drawbar to hoist loadbar or carrier frame. Lock washers or cotter pins must secure pin connections. Lubricate connections for initial startup.
- Power is supplied to system as covered by electrification section. See TC/American Crane Installation Instructions for conductor bar systems and collectors. Use extreme caution when working around electrical conductors.
- Check rotation of motor before tire is adjusted against rail. Press forward and reverse buttons and interchange wires for phasing at motor terminal box to correct travel direction if necessary.
- Adjust tire against bottom of rail, just tight enough so that it will not slip under full load. Tire slippage accelerates tire wear. See *Drive Tire Pressure Adjustment* in these Instructions.
- For drivetractors with brakes - observe whether brake is open and not dragging when unit is running. Check stopping action of brake under full load. Refer to instructions on type of brake and adjust as necessary using manufacturer's instructions.

Initial Start-Up:

- Operate unit through entire system.
- Check clearances of all portions of carrier through curves and switches. See that drivetractor frame, control box, or motor does not contact any portion of carrier on tightest turns both right and left hand.
- Check that swinging of unit does not increase possibility of interference.
- Observe that drawbar does not bind either horizontally or vertically at either end under tightest curve conditions.
- Check operation through all speeds and confirm conformance to specifications.

Hand Chain Drivetractor

Models 2D-231 and 3D-231

(see Figure 1)

- 1) For loads up to 2 ton.
- 2) Flanged wheel trolleys:
 - a) 2T-2000-2
 - b) 3T-2000-2
- 3) Drive Tire pressure adjustment via threaded stud swivel connection to each trolley.
- 4) Tractor movement via hand chain and pocket wheel with single reduction roller chain and sprocket drive to tire.

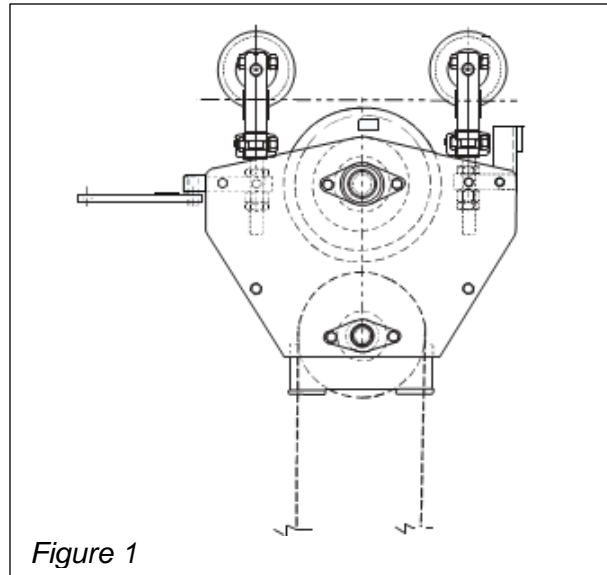

Drive Tire Pressure Adjustment: See Figure 1A. Pressure of the drive wheel to the underside of the patented track tee section is made by raising the drivetractor assembly upwards on the stud swivels connected to each trolley. Loosen jam nuts and adjust the hex nuts on the threaded stud swivels. Adjust the nuts on each stud swivel equally. For additional detail, see *Drive Tire Adjustment* section of these instructions.

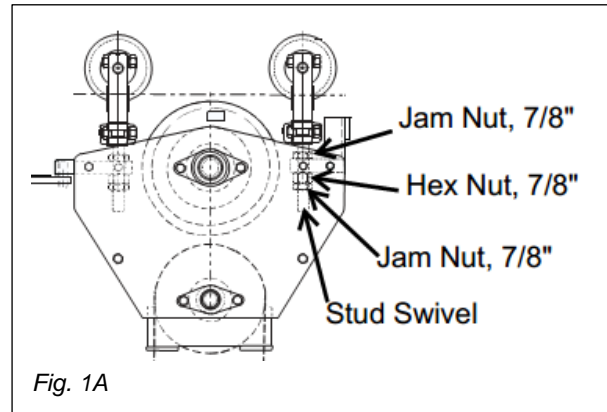

Roller Chain Tension Adjustment: See Figure 1B. Roller chains must be properly tensioned and sprockets in alignment. Chain tension on this drive tractor model is adjusted by loosening bolts on the bearings and adjusting bearing position via the slotted mounting holes. For additional detail, see *Roller Chain Drive Adjustment and Maintenance* section of these instructions.

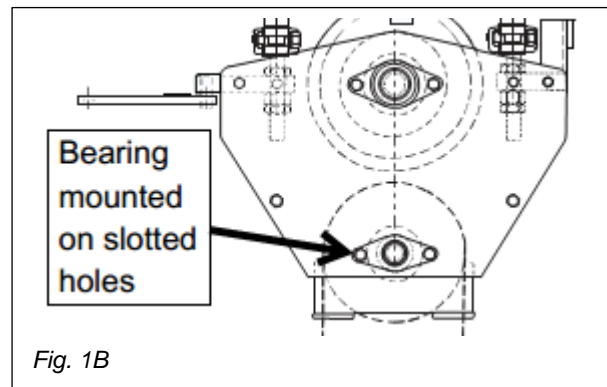

Lubrication: See Figure 1C. This drive tractor has regreaseable bearings at two locations, as shown, and trolleys with grease fittings. For additional detail, see *Lubrication* section of these instructions.

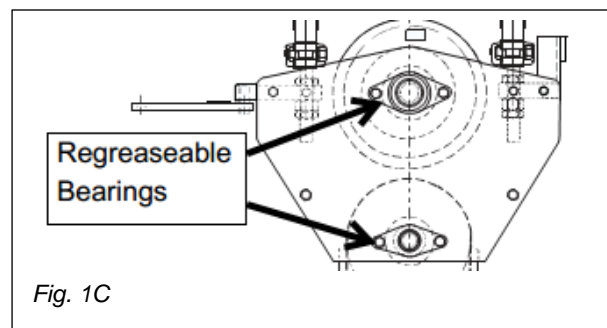

Hand Chain Drivetractor

Model 3D-631
(see Figure 2)

- 1) For loads up to 5 ton.
- 2) Flanged wheel trolleys: 3T-2000-2
- 3) Drive Wheel pressure adjustment via threaded stud swivel connection on each trolley.
- 4) Tractor movement via hand chain and pocket wheel with double reduction roller chain and sprocket drive to tire.

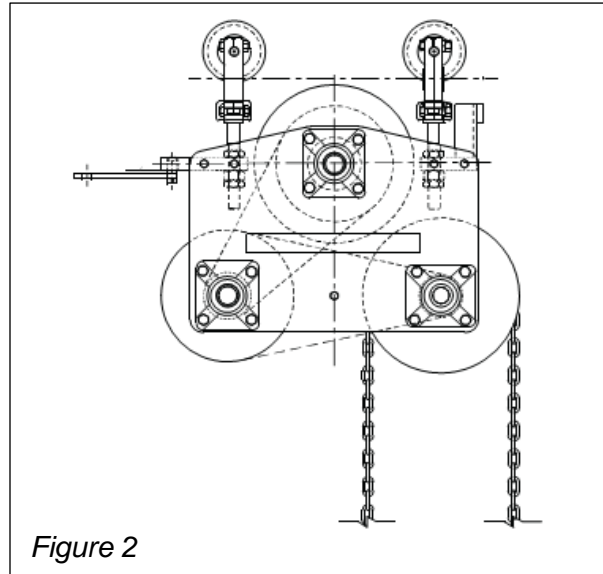

Figure 2

Drive Tire Pressure Adjustment: See Figure 2A. Pressure of the drive wheel to the underside of the patented track tee section is made by raising the drivetractor assembly upwards on the stud swivels connected to each trolley. Loosen jam nuts and adjust the hex nuts on the threaded stud swivels. Adjust the nuts on each stud swivel equally. For additional detail, see *Drive Tire Adjustment* section of these instructions.

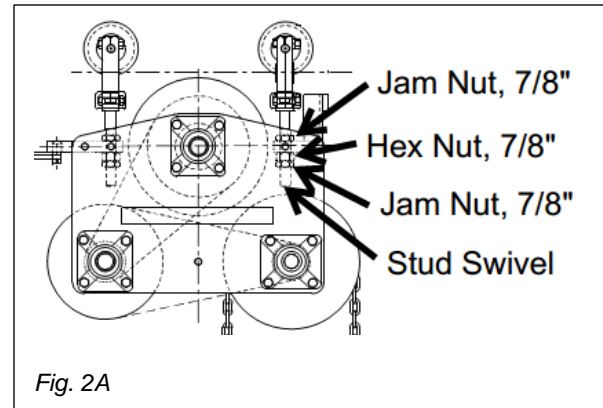

Fig. 2A

Roller Chain Tension Adjustment: See Figure 2B. Roller chains must be properly tensioned and sprockets in alignment. Chain tension on this drive tractor model is adjusted by loosening bolts on the bearings and adjusting bearing positions via the slotted mounting holes. For additional detail, see *Roller Chain Drive Adjustment and Maintenance* section of these instructions.

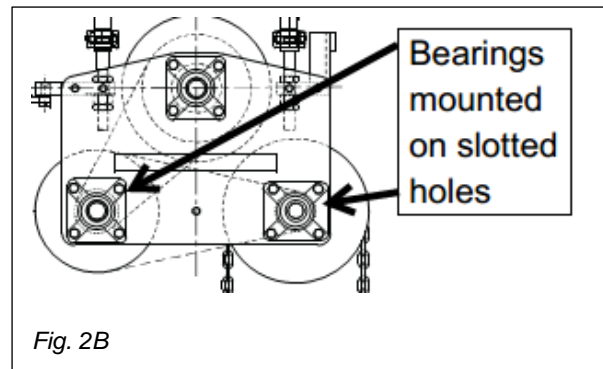

Fig. 2B

Lubrication: See Figure 2C. This drive tractor has regreaseable bearings at three locations, as shown, and trolleys with grease fittings. For additional detail, see *Lubrication* section of these instructions.

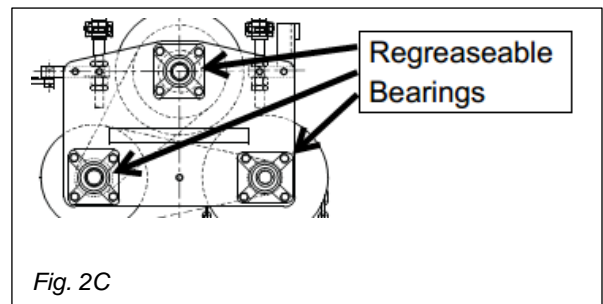

Fig. 2C

Motorized Drivetractor

Models 2D-4000, 2D-4000-SR
 3D-4000, 3D-4000-SR
 (see Figure 3)

- 1) For loads up to 2 ton.
- 2) Flanged or Flangeless wheel trolleys:
 - a) 2T-2000-2; 2T-2000-2SR
 - b) 3T-2000-2; 3T-2000-2SR
- 3) Drive Wheel pressure adjustment via spring loaded threaded stud swivel.
- 4) Right angle gearbox with #50 roller chain to drive wheel sprocket.

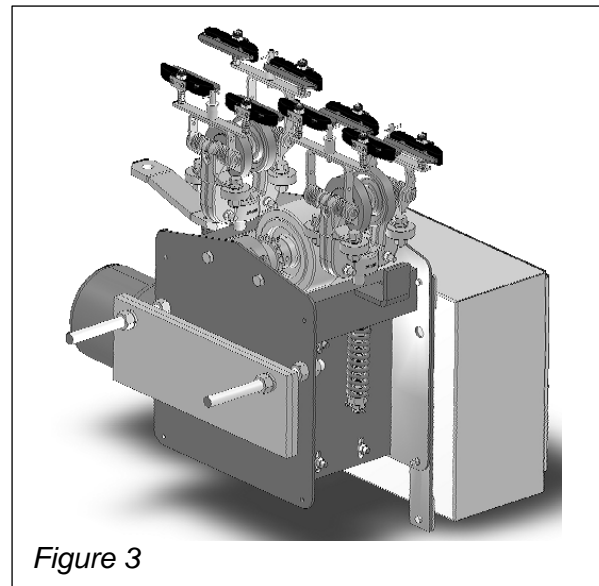

Figure 3

Drive Tire Pressure Adjustment: See Figure 3A. Pressure of the drive wheel to the underside of the patented track tee section is made by compressing the spring on the long stud swivel connected to one trolley. For additional detail, see *Drive Tire Adjustment* section of these instructions.

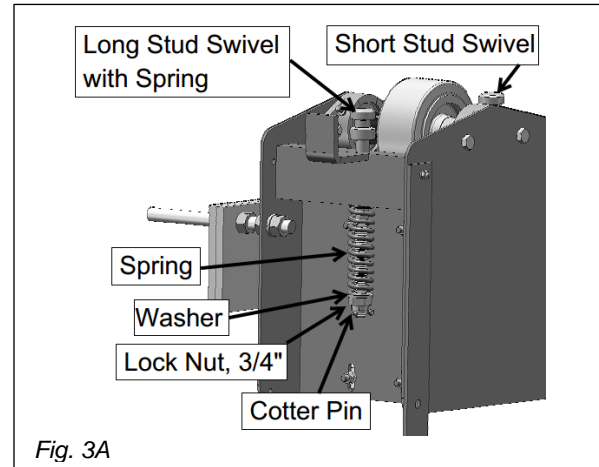

Fig. 3A

Roller Chain Tension Adjustment: See Figure 3B. Roller chains must be properly tensioned and sprockets in alignment. Chain tension on this drive tractor model is adjusted by loosening bolts where the motor and reducer assembly is attached to the tractor frame. For additional detail, see *Roller Chain Drive Adjustment and Maintenance* section of these instructions.

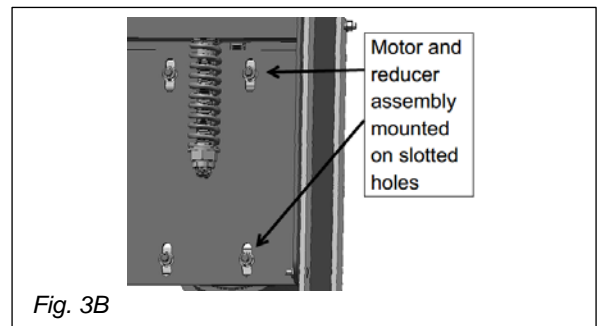

Fig. 3B

Lubrication: See Figure 3C. This drive tractor has regreaseable bearings at two locations, as shown, and trolleys with grease fittings. For additional detail, see *Lubrication* section of these instructions.

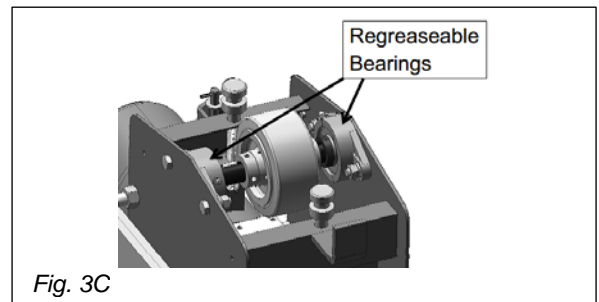

Fig. 3C

Motorized Drivetractor

Models 2D-2256-SR
3D-6256-SR
4D-2256-SR
(see Figure 4)

- 1) For loads up to 5 ton.
- 2) Flangeless wheel trolleys:
 - a) 2T-2000-2SR
 - b) 3T-2000-2SR
 - c) 4T-4100-2SR
- 3) Drive Wheel pressure adjustment via spring loaded threaded stud swivel.
- 4) Right angle worm gearbox and motor assembly with #60 roller chain to drive wheel sprocket.

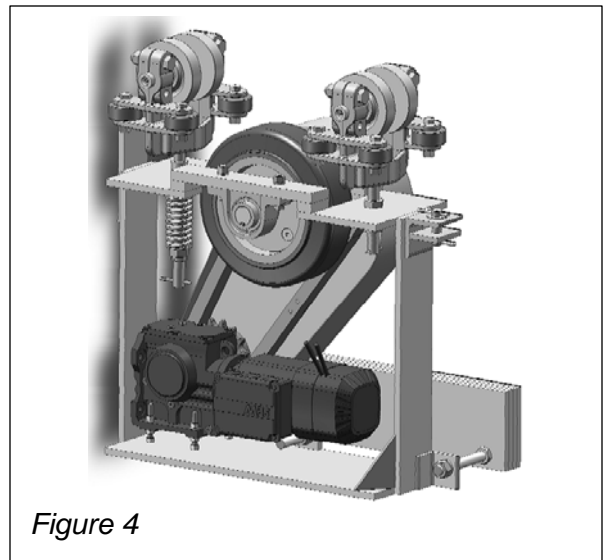

Figure 4

Drive Tire Pressure Adjustment: See Figure 4A. Pressure of the drive wheel to the underside of the patented track tee section is made by compressing the spring on the long stud swivel connected to one trolley. For additional detail, see *Drive Tire Adjustment* section of these instructions.

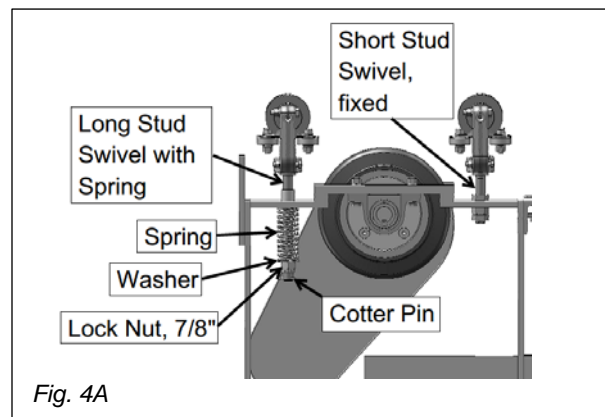

Fig. 4A

Roller Chain Tension Adjustment: See Figure 4B. Roller chain must be properly tensioned and sprockets in alignment. Chain tension on this drive tractor model is adjusted at the mounting bolts for the motor and reducer assembly. Adjust all bolts equally to keep the motor and reducer level and the sprocket aligned with the drive tire sprocket. For additional detail, see *Roller Chain Drive Adjustment and Maintenance* section of these instructions.

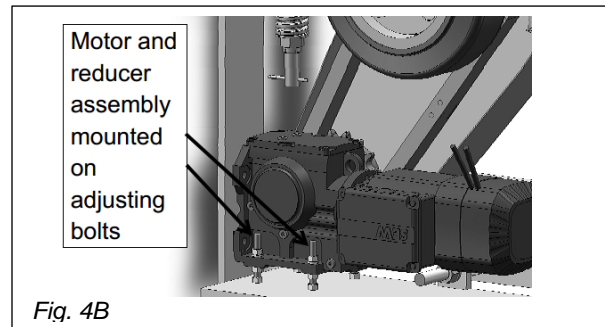

Fig. 4B

Lubrication: See Figure 4C. This drive tractor has regreaseable bearings at two locations, as shown, and trolleys with grease fittings. For additional detail, see *Lubrication* section of these instructions.

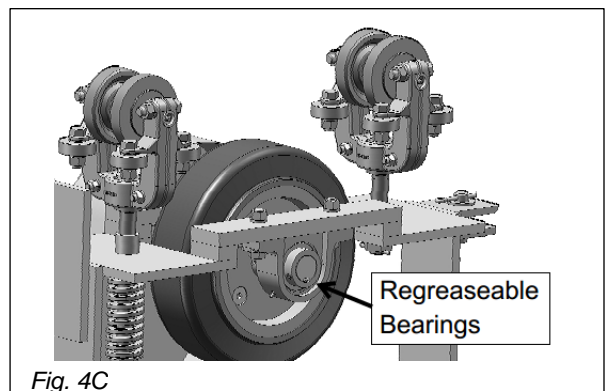

Fig. 4C

Motorized Drivetractor

Models 3D28-300

(see Figure 5)

- 1) For loads up to 10 ton.
- 2) Flangeless wheel trolleys: 3T-6200-2SR
- 3) Drive Wheel pressure adjustment via spring cartridge with adjusting bolt connected to one trolley. Note: for correct drive wheel to underside of rail spacing, drivetractor assembly must be ordered for use on either "L" or "H" series rail.
- 4) Drive assembly is by spur gears within an enclosed gear case.

Drive Tire Pressure Adjustment: See Figure 5A. Pressure of the drive wheel to the underside of the patented track tee section is made by compressing the spring contained within a cartridge under one trolley. To adjust, loosen the two jam nuts and tighten or loosen the set screw in the pipe plug as required. For additional detail, see *Drive Tire Adjustment* section of these instructions.

Note: for correct drive wheel to underside of rail spacing, the drivetractor must have been ordered for use on either "L" or "H" series rail. A tractor made for "H" rail but installed on "L" rail will not have enough adjustment available to bring the drive wheel up to the rail. Conversely, a tractor made for "L" rail but installed on "H" rail may not have enough adjustment to allow the drive wheel to be lowered enough to get the tractor mounted on the rail.

Lubrication: See Figure 5B. This drive tractor uses a TC/American enclosed gearbox. There are no exposed chains, sprockets or bearings. The oil fill plug, level plug and drain plug are as shown in Figure 5B. The drivetractor assembly has a pipe nipple and elbow installed at the fill plug, as shown in Figure 5C. Trolley wheel bearings are regreaseable.

For additional detail, see *Lubrication* section of these instructions.

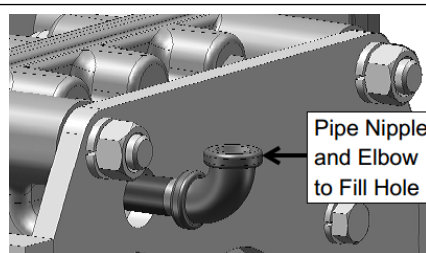

Fig. 5C

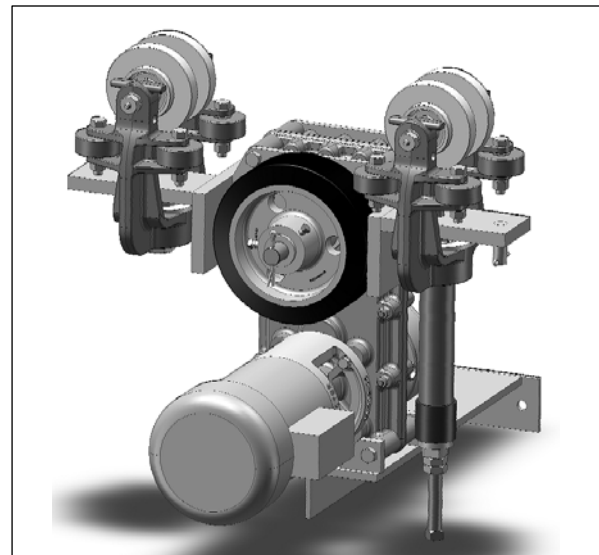

Figure 5

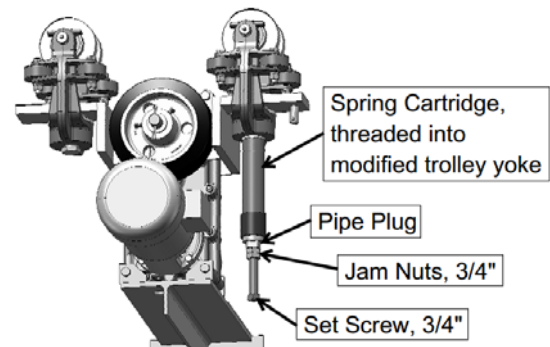

Fig. 5A

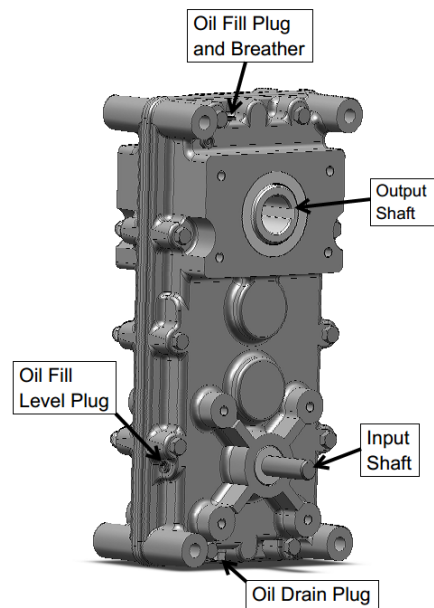

Fig. 5B

Motorized Drivetractor

Models 3D-622
4D-22
(see Figure 6)

- 1) For loads up to 10 ton.
- 2) Flangeless wheel trolleys:
 - a) 3T-4100-2SR
 - b) 4T-4100-2SR
- 3) Drive Wheel pressure adjustment via dual spring loaded threaded stud swivel connected to one trolley.
- 4) Helical gearbox with #80 roller chain and sprocket to drive wheel sprocket.

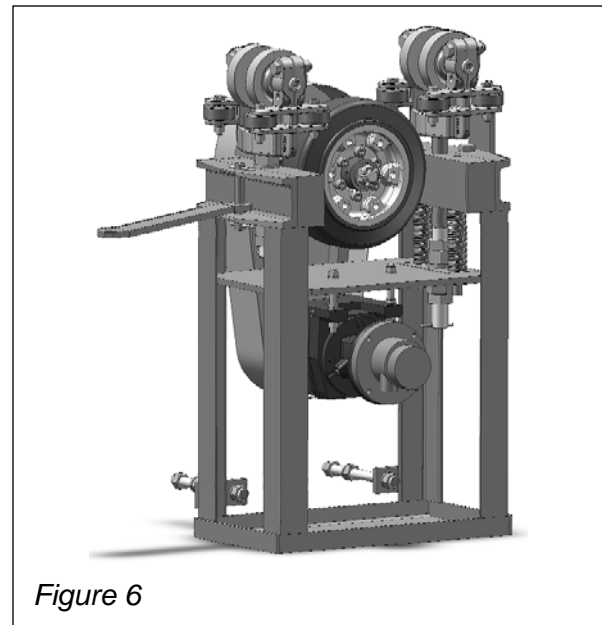

Figure 6

Tire Pressure Adjustment: See Figure 6A. Pressure of the drive wheel to the underside of the patented track tee section is made by tightening or loosening the nuts on the long stud swivel which adjusts the compression of the double springs. For additional detail, see *Drive Tire Adjustment* section of these instructions.

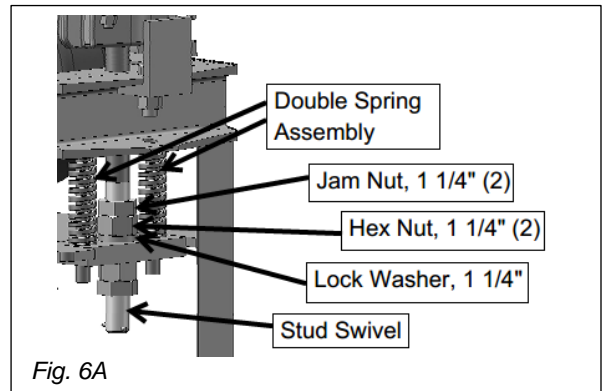

Fig. 6A

Roller Chain Tension Adjustment: See Figure 6B. Roller chain must be properly tensioned and sprockets kept in alignment. Chain tension on this drive tractor model is adjusted at the mounting bolts for the motor and reducer assembly. Adjust all bolts equally to keep the motor and reducer level and the sprocket aligned with the drive tire sprocket. For additional detail, see *Roller Chain Drive Adjustment and Maintenance* section of these instructions.

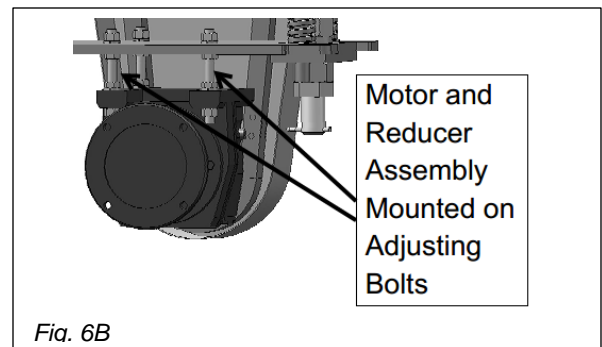

Fig. 6B

Lubrication: See Figure 6C. This drive tractor has a bearing housing to support the drive wheel shaft, with a grease fitting located as shown, and trolleys with grease fittings. For additional detail, see *Lubrication* section of these instructions.

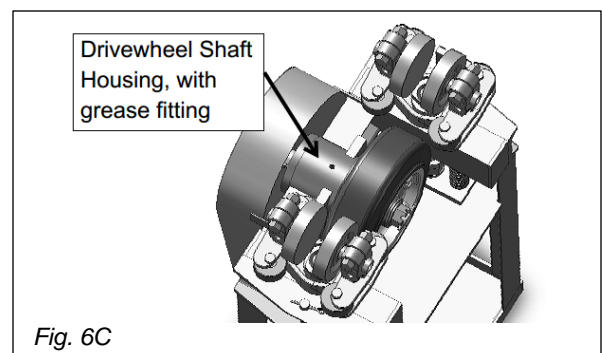

Fig. 6C

Motorized Drivetractor

Models 3D-630
4D-30
(see Figure 7)

- 1) For loads up to 20 ton.
- 2) Flangeless wheel trolleys:
 - a) 3T-4100-2SR
 - b) 4T-4100-2SR
- 3) Drive Wheel pressure adjustment via spring cartridges with adjusting bolt connected to each trolley.
- 4) Tandem Drive Tires
- 5) Helical gearbox with #60-2 roller chain to drive wheel sprockets.

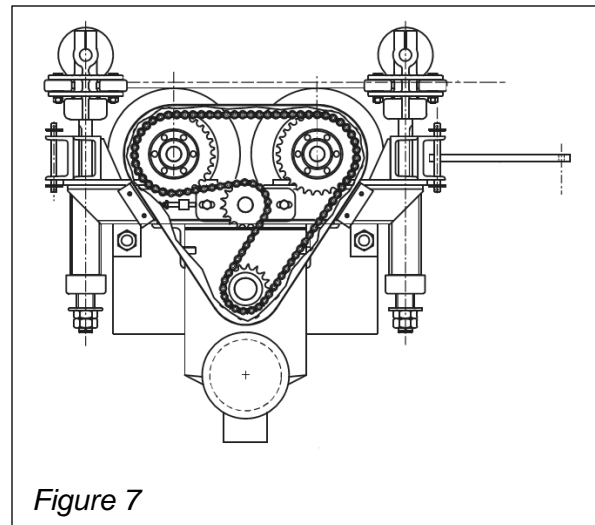

Figure 7

Drive Tire Pressure Adjustment: See Figure 5A. Pressure of the drive wheel to the underside of the patented track tee section is made by compressing the spring contained within a cartridge under one trolley. To adjust, loosen the two jam nuts and tighten or loosen the set screw in the pipe plug as required. For additional detail, see *Drive Tire Adjustment* section of these instructions.

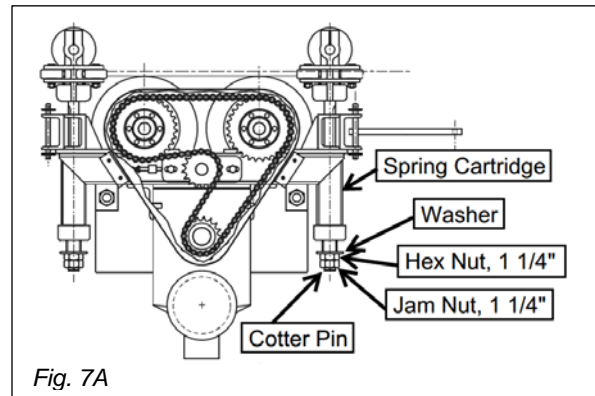

Fig. 7A

Roller Chain Tension Adjustment: See Figure 7B. Roller chains must be properly tensioned and sprockets in alignment. Chain tension on this drive tractor model is adjusted by loosening bolts where the motor and reducer assembly is attached to the tractor frame. For additional detail, see *Roller Chain Drive Adjustment and Maintenance* section of these instructions.

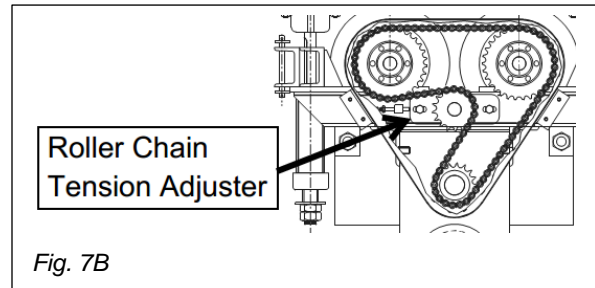

Fig. 7B

Lubrication: See Figure 7C. This drive tractor has a drive shaft bearing housing for each drive wheel, with grease fittings located as shown (bearing support for 3D-622 shown). Trolley wheel bearings are regreaseable. For additional detail, see *Lubrication* section of these instructions.

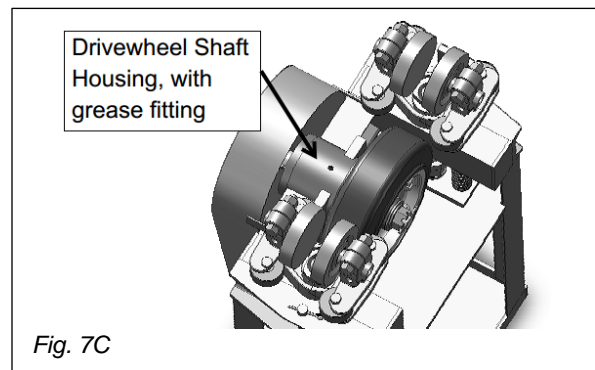

Fig. 7C

Lubrication

General Lubrication Information

1. Drivetractor Trolleys
 - Trolleys with sealed bearings have no grease fittings and require no lubrication.
 - Trolleys with grease fittings in end of axles are packed with grease when assembled. Relubricate after use with multi-purpose lithium grease until a light film of grease appears around wheel axle. Wipe clean after greasing.
 - Apply a light coat of multi-purpose lithium grease to the stud swivel seat area of trolley yokes and to the thrust bearings and spherical seats of those trolleys that have them.

NOTE: For abnormal conditions or temperature extremes, consult TC/American factory.
2. Trolley Side Rollers
 - Side rollers are generally provided with sealed bearings and require no lubrication.
 - Special order tractors may have side rollers that are regreaseable and will have a grease fitting on the side roller axle. Relubricate after use with multi-purpose lithium grease.
3. Motor
 - See the motor information provided with the drivetractor for any lubrication requirements.
4. Motor Brake
 - See the brake information provided with the drivetractor for any lubrication requirements.
5. Reducer (gearbox)
 - a) TC/American Crane motorized drivetractors except the 3D28-300 are provided with a vendor supplied reducer or gearbox.
 - Check lubrication of gear unit. See tags and instructions with drivetractor.
 - Place vent plug in gear case, in place of the topmost pipe plug.
 - Check level plug of oil in gear case and fill to level. Follow manufacturer's recommendation on type of oil and service.
 - b) Drivetractor 3D28-300 has a TC/American Crane gearbox.
 - See Figure 5B on Page 11 for location of Oil Fill Plug / Breather, Oil Fill Level Plug and Oil Drain Plug on gearbox. (Note: locations vary with gearbox orientation.)
 - See Figure 5C on Page 11 – gearbox as incorporated into the tractor frame is provided with a Pipe Nipple and Elbow at the Oil Fill location.
 - Fill to level of Oil Fill Level Plug with SAE 90 Gear Lube (approximately 18 fluid ounces). Allow oil to completely drain down into lower cavity of gearbox before checking level.
 - Assure breather (vent) plug is installed.
 - Verify all other pipe plugs are tight.
6. Roller Chains and Sprockets
 - For drivetractors with roller chain and sprocket drive assembly, use light machine oil to keep chain lubricated. Do not over-lubricate as oil may drip down onto the floor or product.
7. Shaft Bearings and Drive Wheel Shaft Bearing Housing Assemblies
 - Common shaft bearings are greased during assembly. Relubricate after use with multi-purpose lithium grease until a light film of grease appears around the bearing. Wipe clean after greasing.
 - Drive Wheel Shaft Bearing Housing Assemblies as used on 3D-622, 4D-22, 3D-630 and 4D-30 drivetractors have a grease fitting in the housing. The housing is greased during assembly. Relubricate after use with multi-purpose lithium grease until a light film of grease appears around the ends of the housing. Wipe clean after greasing.

Lubrication Frequency

There is no absolute definition or requirement for periodic relubrication of TC/American Crane drivetractors. Each application must be evaluated on its own merits, including: service duty, operating speed, number of operations per shift and operating environment.

After initial installation, verify that all trolleys, bearings, shaft support housings, gearboxes, motors, etc. have been lubricated, either at the factory or in the field.

Operators should make observations before the beginning of each shift for any evidence of oil leaks or grease runs. If noted, notify the maintenance personnel and have them check the equipment and take any needed corrective action.

Inspect all lubrication points after one month of initial use and lubricate as necessary. Inspect monthly thereafter.

Maintenance personnel should develop and maintain a record of all monthly inspections. Frequency of lubrication may be adjusted to match operational demands, based upon the inspection reports.

Recommended Drivetractor Lubricants

Shaft Bearings	Good grade multi-purpose lithium grease
Drive Wheel Shaft Housing Assemblies:	Good grade multi-purpose lithium grease
Trolley Wheels (if regreaseable)	Good grade multi-purpose lithium grease
Side Rollers (if regreaseable)	Good grade multi-purpose lithium grease
Trolley Yoke pocket for Stud Swivel	Good grade multi-purpose lithium grease
Trolley Yoke pocket for Thrust Bearing and Spherical Washer	Good grade multi-purpose lithium grease
Roller Chain	Light machine oil
TC/A gearbox (reducer) for 3D28-300 Drivetractor	SAE 90 gearlube (see operation notice below)
Motor	See vendor manual for recommendations
Brake	See vendor manual for recommendations
Reducer (other than for 3D28-300)	See vendor manual for recommendations

Note: TC/American Crane does not normally make a ‘brand name” recommendation for lubricants. Each customer may have a preference based upon many legitimate reasons. TC/A only recommends to use a “good quality” lubricant and, when one is chosen, to not mix them.

Service of TC/A Gearbox (reducer) for 3D28-300 Drivetractor (based upon ANSI/AGMA 6013-A06)

Initial Lubricant Maintenance: after the first 500 hours of operation or 4 weeks, whichever occurs first, the gear case should be drained, flushed and refilled with clean oil to the proper level. Do not overfill, as too much oil causes excess heating and leakage through the oil seals, decreasing the efficiency of the drive unit. Carefully inspect for any evidence of leakage.

Note: drain oil only after the gear drive is at operating temperature (operate the unit to exercise the drive and warm the oil).

Subsequent Lubricant Maintenance: under normal operating conditions, oil should be changed every 2500 hours or 6 months, whichever occurs first. These change frequencies can be extended if oil analysis indicates that degradation or contamination are within acceptable limits (see examples of typical contamination limits below).

If drive units exposed to outside weather conditions and are not operated during the winter: the gear case should be completely filled with oil to prevent moisture and rust from forming in the case. Drain oil to proper oil level before restarting the drive unit.

Abnormal Operating Conditions: rises and falls in temperature may produce internal condensation. Dust, dirt, chemical particles or fumes may react with the oil to form sludge. High temperatures may cause accelerated degradation of the oil. Under these conditions, the oil should be examined more frequently and changed as required. Each installation under these conditions must have a locally determined oil maintenance policy established.

An oil testing or examination program should include testing for:

- Changes in appearance or color
- Oil viscosity (oxidation)
- Water concentration
- Contaminant concentration
- Sediment and sludge
- Additive concentration and condition

General guidelines for contamination limits (when to change oil) are:

- Water content greater than 0.05% (500 ppm)
- Iron content exceeds 150 ppm
- Silicon (dust/dirt) exceeds 25 ppm
- Viscosity changes more than 15%

Tests should be performed on the initial fill of oil to establish a baseline for comparison.

Drive Tire Adjustment

Note – correct pressure of the drive tire to the underside of the rail is of great importance because:





- excessive tire pressure caused by over-tightening the adjusters will cause excessive tire wear and premature tire failure
- excessive tire pressure puts undue stress on other components (motor, shafts, bearings and trolley wheels)
- excessive tire pressure prevents proper operation on curves
- excess tire pressure causes an excessive kick-up force at switches, lift sections or other similar equipment
- insufficient tire pressure will cause the drive wheel to slip, making starts and stops difficult to control.

Drive Tire Pressure Adjustment Procedure:

All TC/American Crane drivetractors are provided with variations of a spring loaded adjuster under the trolley(s). Drive tire pressure against the underside of the rail is increased by compressing the spring(s) or decreased by relieving the compression.

Note: this procedure is applicable to all TC/American Crane drivetractor models. Some models have spring pressure adjustment on both trolleys, while others have it on just one.

- 1) Make pressure adjustments when the unit is fully loaded (pulling or pushing the full design load).
- 2) If your tractor model has spring adjusters under both trolleys, adjust both the fore and aft trolleys simultaneously. The frame of the drivetractor must be kept level in relationship to the runway rail.
- 3) Several repeated adjustments may be in order:
 - a) Start with the drive wheel just touching the rail and tighten the pressure nut(s) or screw one full turn.
 - b) Start and stop the drivetractor from the pushbutton station.

-  **Danger** Be sure that all personnel are clear of the conductor bars and collectors.
-  **Warning** Be sure the path of the tractor, hoist, crane and any supported load is clear.
-  **Caution** Be sure that all personnel are clear of the drivetractor drive wheel and drive mechanism.
-  **Caution** Be sure that the person operating the tractor controls via the pushbutton or other control device understands the test procedure and that clear communication signals have been developed and understood.

- c) If the tire slips in either direction, adjust the pressure nut(s) or screw **one half** turn; start and stop the drivetractor again.
- d) If the tire slips in either direction again, adjust pressure nut(s) or screw **one half** turn.
- e) Continue until the tire does not slip at initial start or stop.
- f) When this “minimal slip” setting is achieved, tighten the pressure nuts one more **half** turn and, if provided with jam nuts instead of a locknut, tighten jam nut against the pressure adjusting nut.

Drivetractor Balancing

Drivetractors must be weighted so they hang straight under the rail. Factory assembled tractors are provided with counterbalance weights as required. Field assembled tractors must be balanced after all controls and other accessories are installed. Weights are mounted on brackets that provided some adjustability. However, in some cases additional weights may need to be provided locally. Balance tractor to within 1 degree of true horizontal level.

Options

TC/American Crane Drivetractors are normally shipped fully assembled. However, tractors may be ordered with or without controls, collectors and other options, so some field assembly may be required. See the drawings provided with the shipment for guidance.

There are many options available to customize a TC/American Crane drivetractor to the exact needs of a customer. For information about these options, please see the drawings shipped with the drivetractor.

Mechanical Options may include:

Special Horsepower
 Special Speeds
 Heat Shields
 Safety Lugs
 Special Towbar (drawbar)
 Drawbar Release Mechanism (manual)
 Remote Controlled Drawbar Grab/Release Mechanism
 Drivewheel Release Mechanism
 Special Bumpers
 Spark Resistant Trolley Wheels and Side Rollers
 Special Brakes
 High Temperature Grease
 Pendant Station Support Arm, Fixed or Pivoting
 Rail Sweeps
 Special Paint
 Air Operation
 Other (per request)

Electrical Options may include:

Electrical Collectors
 Special Control Enclosures
 Special Voltages
 Remote Control
 Air Conditioner in Control Enclosure for High Temp Environment
 Travel Limit Switches
 Special Drives (High Horsepower; High Acceleration Rate; Slow Speeds; Multiple Speeds, etc.)
 Magnetic Disconnects
 Control Panel Motor Overload Protection
 Pilot Lights
 Warning Lights
 Warning Horn
 Circuit Breakers
 Other (per request)

Roller Chain Drive Adjustment and Maintenance

Note: the following is from general information and guidance provided by the roller chain industry. Some sections may not be applicable for drive tractor use.

All chain drives require regular maintenance. Each drive should be inspected after the initial 100 hours of operation. Thereafter, most drives may be inspected at 500 hour intervals. However, drives subjected to shock loads or severe operating conditions should be inspected at 200 hour intervals. At each inspection, the following items should be checked and corrected, if necessary.

 **WARNING**

You may be seriously injured if you attempt to install chain on equipment under power. Shut off power and lock out gears and sprockets before attempting installation or maintenance.

1. Check lubrication

On slow speed drives, where manual lubrication is used, be sure the lubrication schedule is being followed. If the chain is covered with dirt and debris, clean the chain with kerosene and relubricate it.

(Note: kerosene is a “combustible liquid” as compared to a “flammable liquid” such as gasoline. Proper precautions in storing, handling and disposal of kerosene must be followed. Refer to MSDS sheets.)

 **WARNING**

Never use gasoline or other flammable solvents to clean a chain. A fire may result, and these products may be hazardous to your health.

If drip lubrication is used, check for adequate oil flow and proper application to the chain. With bath or pump lubrication, check oil level and add oil if needed. Check oil for contamination and change oil if needed. Change oil after the first 100 hours of operation and each 500 hours thereafter. If pump lubrication is used, check each orifice to be sure it is clear and is directing oil onto the chain properly.

2. Check Chain Tension

Check chain tension and adjust as needed to maintain the proper sag in the slack span. If elongation exceeds the available adjustment, remove two pitches and reconnect the chain.

3. Check Chain Wear

Measure the chain wear elongation and if elongation exceeds functional limits or is greater than 3% (.36 inches in one foot) replace the entire chain. Do not connect a new section of chain to a worn chain because it may run rough and damage the drive. Do not continue to run a chain worn beyond 3% elongation because the chain will not engage the sprockets properly and it may damage the sprockets.

4. Check Sprocket Tooth Wear

Check for roughness or binding when the chain engages or disengages from the sprocket. Inspect the sprocket teeth for reduced tooth section and hooked tooth tips. If these conditions are present, the sprocket teeth are excessively worn and the sprocket should be replaced. Do not run new chain on

worn sprockets as it will cause the new chain to wear rapidly. Conversely, do not run a worn chain on new sprockets as it will cause the new sprockets to wear rapidly.

5. Check Sprocket Alignment

If there is noticeable wear on the inside surface of the chain roller linkplates, the sprockets may be misaligned. Realign the sprockets as outlined in the installation instructions to prevent further abnormal chain and sprocket wear.

6. Check for Drive Interference

Check for interference between the drive and other parts of the equipment. If there is any, correct it immediately. Interference can cause abnormal and potentially destructive wear on the chain or the interfering part. If the edges of the chain linkplates impact against a rigid part, linkplate fatigue and chain failure can result.

Check for and eliminate any buildup of debris or foreign material between the chain and sprockets.

A relatively small amount of debris in the sprocket roll seat can cause tensile loads great enough to break the chain if forced through the drive.

7. Check for Failure

Inspect the chain for cracked, broken or deformed parts. If any of these conditions are found, **REPLACE THE ENTIRE CHAIN**, even though portions of the chain appear to be in good condition. In all likelihood, the entire chain has been damaged.

Troubleshooting Guide

CONDITION/SYMPATOM	POSSIBLE CAUSE	WHAT TO DO
Tight Joints		
	• Dirt or foreign material in chain joints.	Clean and relubricate chain.
	• Inadequate lubrication.	Replace chain. Re-establish proper lubrication.
	• Misalignment.	Replace sprockets and chain if needed. Realign sprockets.
	• Internal corrosion or rust.	Replace chain. Eliminate cause of corrosion or protect chain.
	• Overload bends pins or spreads roller.	Replace chain. Eliminate cause of overload.
<hr/>		
Rusted Chain	• Exposed to moisture.	Replace chain. Protect from moisture.
	• Water in lubricant.	Change lubricant. Protect lubrication system from water. Replace chain.

- **Inadequate lubrication.**

Provide or re-establish proper lubrication. Replace chain, if needed.

Turned Pins

- **Inadequate lubrication.** Replace chain. Re-establish proper lubrication.



Enlarged Holes

- **Overload.** Replace chain. Eliminate cause of overload.



Broken Pins

- **Extreme overload.** Replace chain. Replace sprockets if indicated. Eliminate cause of overload or redesign drive for larger pitch chain.

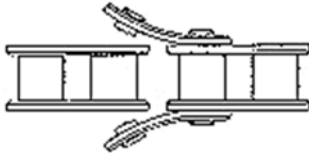

Broken Link Plates

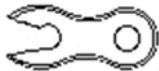

Missing Parts

- **Missing at assembly.** Replace chain.
- **Broken and lost.** Find and correct cause of damage. Replace chain.

Broken, Cracked or Deformed Rollers



- **Speed too high.** Replace chain. Reduce speed.
- **Sprockets too small.** Replace chain. Use larger sprockets, or possibly redesign drive for smaller pitch chain.
- **Chain riding too high on sprocket teeth.** Replace chain. Retension chain more often.

Pin Galling

- **Inadequate lubrication.** Reduce speed or load. Possibly redesign drive for smaller pitch chain. Provide or re-establish proper lubrication.



Chains Climbs Sprocket Teeth	<ul style="list-style-type: none">• Excess chain slack.	Retension chain.
	<ul style="list-style-type: none">• Excessive chain wear.	Replace and retension chain.
	<ul style="list-style-type: none">• Excessive sprocket wear.	Replace sprockets and chain.
	<ul style="list-style-type: none">• Excessive overload.	Replace chain. Eliminate cause or overload.

Missing or Broken Cotters	<ul style="list-style-type: none">• Cotters installed improperly.	Install new cotters per manufacturer's instructions.
	<ul style="list-style-type: none">• Vibration.	Replace chain. Reduce vibration. Use larger sprockets.
	<ul style="list-style-type: none">• Excessively high speed.	Replace chain. Reduce speed. Redesign drive for smaller pitch chain.

Exposed Chain Surfaces Corroded or Pitted	<ul style="list-style-type: none">• Exposure to corrosive environment.	Replace chain. Protect from hostile environment.
--	---	--

Cracked Link Plates (Stress Corrosion)	<ul style="list-style-type: none">• Exposure to corrosive environment combined with stress from press fits.	Replace chain. Protect from hostile environment.
---	--	--



Cracked Link Plates (Fatigue)	<ul style="list-style-type: none">• Loading greater than chain's dynamic capacity.	Replace chain. Reduce dynamic loading or redesign drive for larger chain.
--------------------------------------	---	---

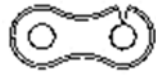

Battered Link Plate Edges	<ul style="list-style-type: none">• Chain striking an obstruction.	Replace chain. Eliminate interference.
----------------------------------	---	--

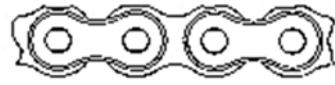

Worn Link Plate Contours	<ul style="list-style-type: none">• Chain rubbing on casing, guide, or obstruction.	Replace chain if 5% or more of height worn away. Retension chain. Eliminate interference.
---------------------------------	--	---



Excessive Noise

- **Chain striking an obstruction.** Replace chain. Eliminate interference.
- **Loose casing or shaft mounts.** Tighten fasteners.
- **Excess chain slack.** Retension chain..
- **Excessive chain wear.** Replace and retension chain.
- **Excessive sprocket wear.** Replace sprockets and chain.
- **Sprocket misalignment.** Replace chain and sprockets, if needed. Realign sprockets.
- **Inadequate lubrication.** Replace chain if needed. Re-establish proper lubrication.
- **Chain pitch too large.** Redesign drive for smaller pitch chain.
- **Too few sprocket teeth.** Check to see if larger sprockets can be used. If not, redesign drive.

Wear on Inside of Roller Link Plates and one side of Sprockets.

- **Sprocket misalignment.** Replace sprockets and chain if needed. Realign drive. Retension chain..

Chain Clings to Sprocket

- **Excessive sprocket wear.** Replace sprockets and chain.
- **Sprocket misalignment.** Replace sprockets and chain if needed. Realign sprockets.