

End Trucks 325 Series

These instructions are for 325 Series End Trucks, as used on TC/American Crane 325 Series Patented Track rail. See the Index to locate the appropriate pages for the model of end truck being used.

For detailed information about the idler (plain) trolleys and motorized trolleys used on these end trucks, see *325 Series Trolleys Installation Instructions* and *Motorized Trolleys Installation Instructions*.

DANGER

Lifting Operations

Installation of equipment such as TC/American Crane's End Trucks requires performance of overhead lifting operations. Proper lifting procedures involve training, skills and experience beyond the scope of this document. Workplace supervisors are responsible to assure that all persons under their supervision are properly trained, properly equipped, and are following safety practices appropriate for the lifting operation being employed.

DANGER

Overhead Mechanical Assembly

Persons performing installation and assembly of overhead equipment must use caution while lifting, assembling and adjusting components. These operations are frequently conducted from manlifts or platforms that require specific knowledge, training and operation skills beyond the scope of this document.

Access to the floor below the work area must be restricted to reduce the potential of personnel injury due to falling objects.

Workplace supervisors are responsible to assure that all persons under their supervision are properly trained, properly equipped, and are following appropriate safety practices.

DANGER

Electrical Equipment Installation, Service and Maintenance

Persons performing installation, service or maintenance activities on, near, or with equipment that is electrically powered are exposed to electrical hazards that could result in serious injury or death if proper precautions are not followed. Before performing such work, disconnect the electrical power source for the system at the disconnect device and lock it out, following appropriate Lockout/Tagout (LOTO) procedures, to prevent electric power from being applied while work is being performed.

All persons must use safe work practices appropriate to the electrical system, and follow all workplace procedures and policies. This requires specific knowledge, equipment and training beyond the scope of this document. Workplace supervisors are responsible to assure that all persons under their supervision are properly trained, properly equipped, and are following appropriate safety practices.

Index

Item	Page
A. General Safety Alerts	1
B. End Truck Model Numbers and Descriptions.....	3
C. General Installation Instructions	
D. Before Beginning Installation	4
E. Assembling Trolleys on End Trucks	4
F. Installing End Trucks on Rail	4
G. Initial Start-Up	4
H. 325 Series End Trucks	
I. 4-Wheel End Trucks	
J. 3ET-1300-4.....	5
K. 3ET-2600-4, 3ET-2600-4SR.....	6
L. 3ET-5400-4, 3ET-5400-4SR.....	8
M. 3ET-9000-4, 3ET-9000-4SR, 3ET-9000-4X, 3ET-9000-4XSR	
N. 3ET-124000-4, 3ET-124000-4SR	
O. 3ET-16000-4, 3ET-16000-4SR	10
P. End Truck Frame Configuration, for correct location of Idler	
Q. Trolleys and Motorized Trolleys on saddles, for 3ET-9000,	
R. 3ET-12400 and 3ET-16000 End Trucks	11
S. 3ET-20000-4SR.....	12
T. 8-Wheel End Trucks	
U. 3ET-24800-8, 3ET-24800-8SR, 3ET-28000-8, 3ET-28000-8SR	14
V. 3ET-38000-8SR.....	17
W. Drive Tire Adjustment.....	20
X. Lubrication	20

End Trucks

TC/American Crane offers several models of end trucks for use on cranes or carriers. Selection of the appropriate model depends upon the size of the rail on which the end truck will operate, the load to be carried, powered travel or hand pushed, service duty class, and other factors.

End Truck Model Numbers:

(general information for all end trucks)

- The first character(s) of the Model Number identifies the rail size on which the End Truck operates:
 - 2 = 200 Series Rail
 - 3 = 325 Series Rail
 - 4 = 400 Series Rail
 - 45 = 450 Series Rail
- The second characters, "ET," identify the product as an "End Truck."
- The intermediate numbers are the end truck capacity; i.e.:
 - 2600 = 2600 pound capacity
 - 5400 = 5400 pound capacity
 - 12400 = 12400 pound capacity
 - 16000 = 16000 pound capacity
 - etc.
- The next number, or number and letters, identify the end truck by number of wheels, trolley type and, in some cases, wheelbase:
 - 4 = 4-wheel end truck with flanged wheels (end truck has two 2-wheel trolleys)
 - 4L = 4-wheel end truck with flanged wheels and longer than standard wheelbase
 - 4SR = 4-wheel end truck with flangeless wheels and side rollers ("SR")
 - 4SRL = 4-wheel end truck with flangeless wheels, side rollers and longer wheelbase
 - 4X = 4-wheel end truck with flanged wheels and shorter than standard wheelbase
 - 8 = 8-wheel end truck with flanged wheels (end truck has two 4-wheel trolleys)
 - 8L = 8-wheel end truck with flanged wheels and longer than standard wheelbase
 - 8SR = 8-wheel end truck with flangeless wheels and side rollers ("SR")
 - 8SRL = 8-wheel end truck with flangeless wheels, side rollers and longer wheelbase
- The last character of the model number (if present) identifies the type of motorized trolley drive used on the end truck:
 - None = No motorized trolley drive used, or none available
 - A = "A" Drive
 - AT = "AT" Drive
 - B = "B" Drive
 - C = "C" Drive

Note: Many end trucks may be used with a drive tire system (either rubber or polyurethane tire pressing against the underside of the riding tread). These end trucks do not have a unique model identification. See the TC/American Crane Systems Catalog for end trucks that may be used in this application (requires adequate wheelbase length).

NOTE: See the appropriate section(s) of these instructions for assembly, installation and maintenance details specific to your End Truck model.

NOTE: For a specific parts breakdown of the End Truck provided with an order, see the drawings provided with that shipment and the End Truck Section of TC/American Crane Systems Catalog.

General Installation Instructions

Before beginning the installation:

- When shipment is received, remove all shipping materials and check all parts for damage. Repair and/or replace if necessary.
- Check packing lists against materials received and identify all parts.
- Gather all TC/American Crane drawings, other vendor equipment drawings, and associated manuals (motor, reducer, brake, electrical components, etc.) as applicable and keep in a secure location for reference during installation and start-up, and to give to end user for future reference.
- Turn trolley wheels and guide rollers by hand to check for possible damage in shipment. Check for rough bearings, loose bearings and axles.
- Check electrical collectors (if provided) for condition and proper operation. Check collector wiring for routing and security.
- Store all equipment in a clean, secure area prior to final assembly.

Assembling Trolleys on End Trucks:

- Check crane or layout drawings for any notes about crane orientation or trolley positions.
- End trucks are normally assembled to a bridge beam rail or a hoist carrier frame, and will be handled as part of a crane or carrier assembly.
- TC/American Crane End Trucks may be shipped with trolleys installed or removed, depending upon model of end truck.

Idler (Plain) Trolleys:

- See the Index for the appropriate pages of this document for assembly instructions and illustrations for the end truck being used.
- Also see *325 Series Trolleys Installation Instructions*.

Motorized Trolleys:

- Some end trucks are not designed for motorized trolleys.
- See the Index for the appropriate pages of this document for assembly instructions and illustrations for the end truck being used.
- Also see *Motorized Trolley Installation Instructions*.

Installing End Trucks on Rail:

- See the Installation Procedure (and Options) described on the pages for each model of end truck. See the Index for appropriate pages.
- Lift components into position on runway or monorail and re-assemble. Use extreme caution when lifting equipment into place.

Initial Start-Up:

- Operate crane through entire length of system.
- Check clearances of trolleys to rail at rail joint bolts and suspension hardware.
- Check clearances of all portions of crane to the surrounding structures.
- Check operation through all speeds and verify conformance to specifications.

325 Series End Trucks

4-Wheel End Trucks

3ET-1300-4 Figure 1

For general end truck assembly, see Figure 1.

See Figures 2 and 3 for trolley details.

There is no motorized trolley available for this end truck.

For installation of end trucks on rail, see methods described below.

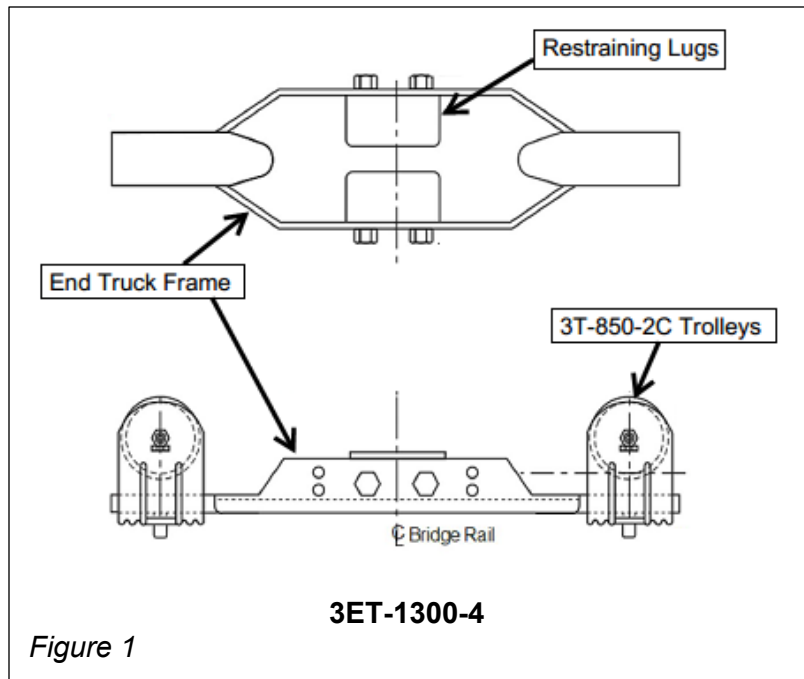

Figure 1

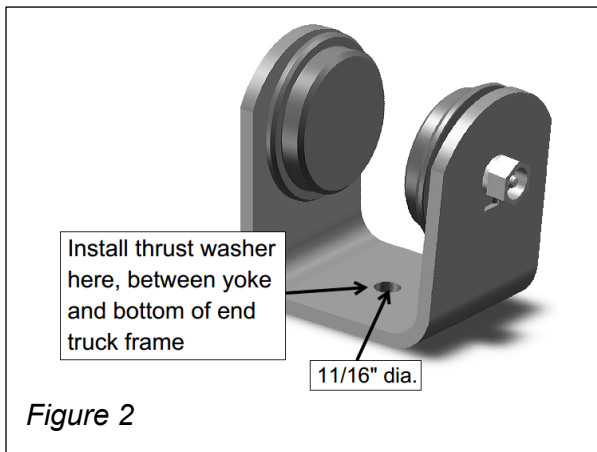

Figure 2

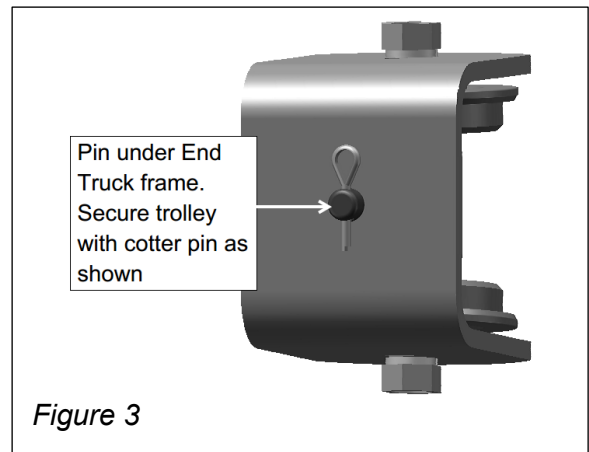

Figure 3

Procedure and Options to install 3ET-1300-4 end trucks on rail:

- a)
 1. Remove trolleys from end trucks (if shipped mounted)
 2. Place trolleys on rail
 3. Remove restraining lugs from end truck
 4. Lift crane into position under rail
 5. Roll trolleys onto each end of end truck, verify thrust washer is in place (see Figure 2), position end truck pin into hole in trolley yoke, secure with cotter pin as shown in Figure 3
 6. Reassemble restraining lugs
- b)
 1. Remove trolley wheels from each trolley yoke, leaving yokes attached to end truck frame
 2. Remove restraining lugs from end truck
 3. Lift crane into position under rail, with yokes straddling rail
 4. Reassemble trolley wheels to yokes.
 5. Reassemble restraining lugs
- c)
 1. Thread assembled end trucks and trolleys of crane or carrier onto rails at open ends (end stop removed)

325 Series End Trucks

4-Wheel End Trucks

- 3ET-2600-4** Figure 4
- 3ET-2600-4SR** Not Shown
(similar to 3ET-2600-4, but with side roller trolleys)

For general end truck assembly, see Figures 4, 5 and 6

There is no motorized trolley available for this end truck.

For installation of end trucks on rail, see methods described on next page.

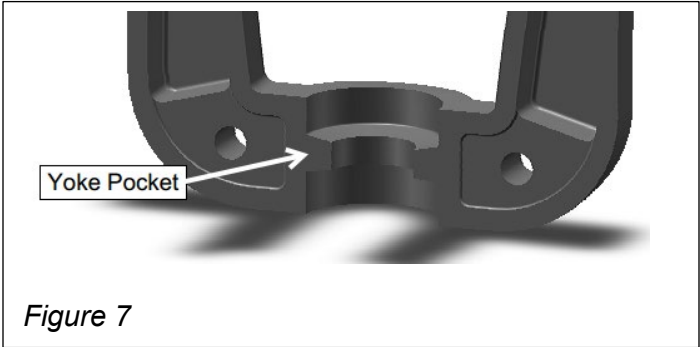
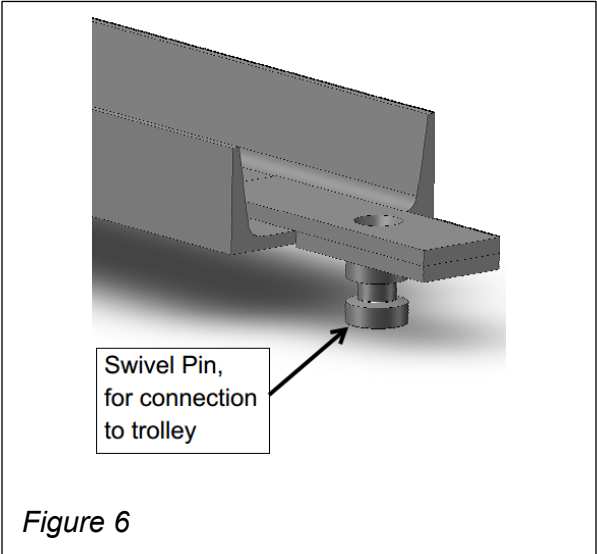
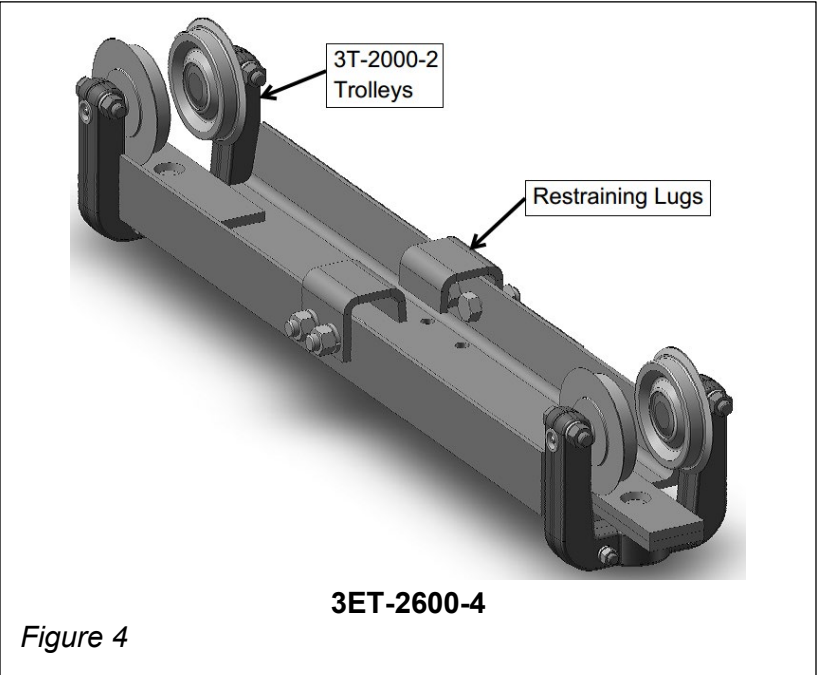

Procedure and Option to install 3ET-2600-4 or -4SR end trucks on rail:

- a)
 - 1. Disassemble trolleys from end trucks (if shipped mounted). Note: trolleys have “bolt-together” yokes with “pockets” or “cavities” as shown in Figure 7 to contain the heads of end truck swivel pins
 - 2. Remove restraining lugs from end truck
 - 3. Lift crane into position under rail
 - 4. Reassemble trolley yokes and wheels onto end truck swivel pins at each end of end truck
 - 5. Reassemble restraining lugs
- b)
 - 1. Thread assembled end trucks and trolleys of crane or carrier onto rails at open ends (end stop removed)

325 Series End Trucks

4-Wheel End Trucks

- 3ET-5400-4** 3'-3" wheelbase Figure 8
- 3ET-5400-4SR** 3'-3" wheelbase Not Shown
(same as above, but with flangeless wheels)
- 3ET-5400-4SR** 6'-0" wheelbase Figure 9

For general end truck assembly, see Figures 8, 9, 10, 11 and 12.

There is no motorized trolley available for this end truck.

For installation of end trucks on rail, see methods described on next page.

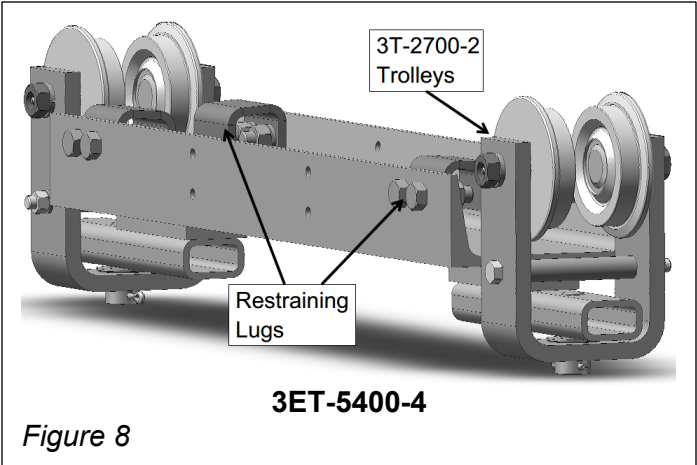

Figure 8

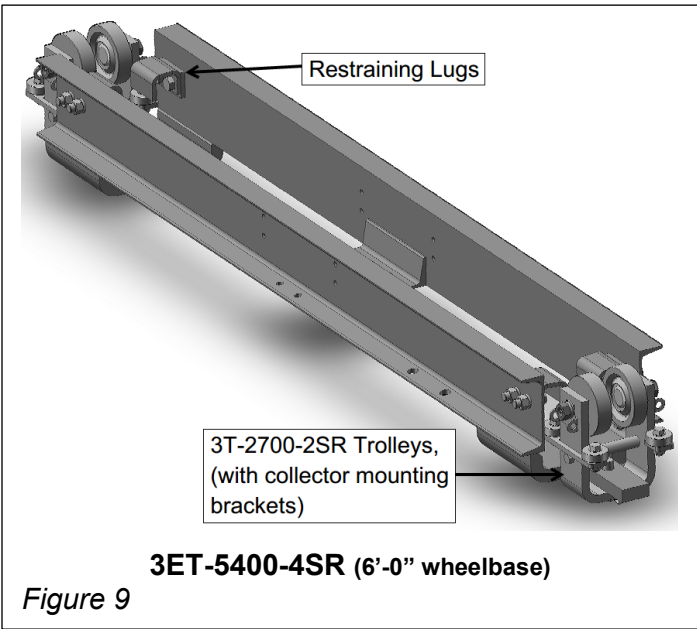

Figure 9

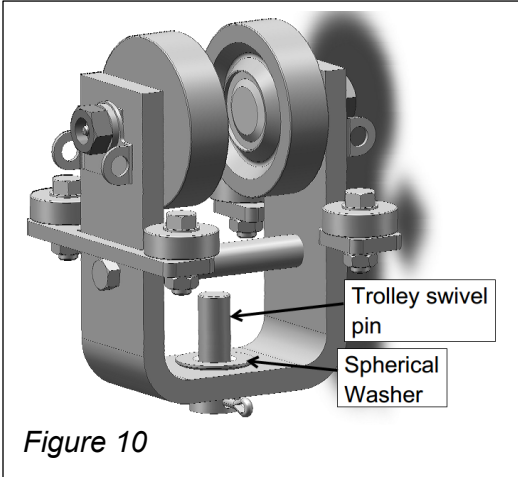

Figure 10

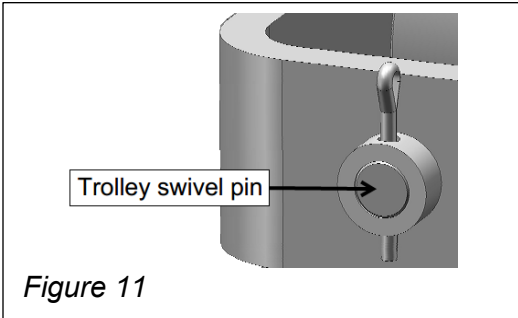

Figure 11

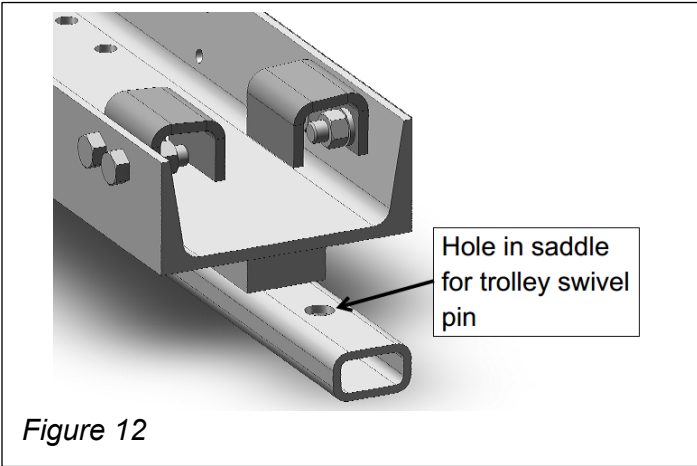

Figure 12

Procedure and Options to install 3ET-5400-4 or -4SR end trucks on rail:

- a)
 - 1. Remove trolleys from end trucks (if shipped mounted)
 - 2. Place trolleys on rail
 - 3. Remove restraining lugs from end truck
 - 4. Lift crane into position under rail
 - 5. Roll trolleys onto each end of end truck, verify spherical washer is in place (see Fig. 10)
 - 6. Insert trolley swivel pin from bottom of trolley through spherical washer and into hole in trolley load bar (see Fig. 12), secure with cotter pin (see Fig. 11).
 - 7. Reassemble restraining lugs
- b)
 - 1. Remove trolley wheels from each trolley yoke, leaving yokes attached to end truck frame (with trolley swivel pin in place and trolley cross bolt resting on end truck load bar)
 - 2. Remove restraining lugs from end truck
 - 3. Lift crane into position under rail, with yokes straddling rail
 - 4. Reassemble trolley wheels to yokes.
 - 5. Reassemble restraining lugs
- c)
 - 1. Thread assembled end trucks and trolleys of crane or carrier onto rails at open ends (end stop removed)

325 Series End Trucks

4-Wheel End Trucks

- 3ET-9000-4** Figure 13
- 3ET-9000-4SR** Not Shown
(same as above, but with flangeless wheels)
- 3ET-9000-4X** Not Shown
- 3ET-9000-4XSR** Not Shown
(-4X and -4XSR have 45" wheelbase; saddles do not accept motorized trolley)
- 3ET-12400-4** Figure 14
- 3ET-12400-4SR** Not Shown
(same as above, but with flangeless wheels)
- 3ET-16000-4** Not Shown
- 3ET-16000-4SR** Not Shown
- Other variants, with longer or shorter wheelbase** Not Shown

For general end truck assembly, see Figures 13, 14, 15, 16 and 17.

Note: 3ET-16000 end trucks not shown; configuration similar to those shown.

Note: for correct position of idler trolley and motorized trolley on end truck frame, see Figure 18 on next page.

For directions on installing Motorized Trolleys on saddle, see *Motorized Trolley Installation Instructions*.

For installation of end trucks on rail, see methods described on next page.

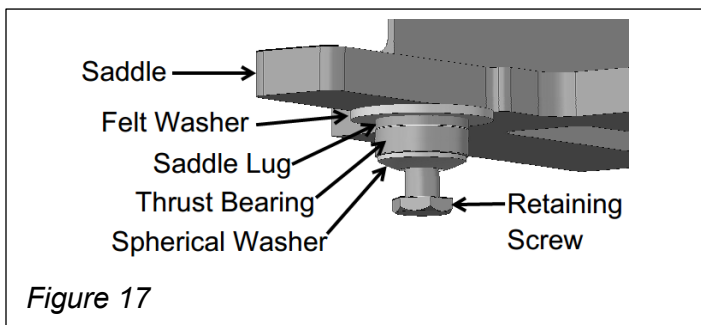
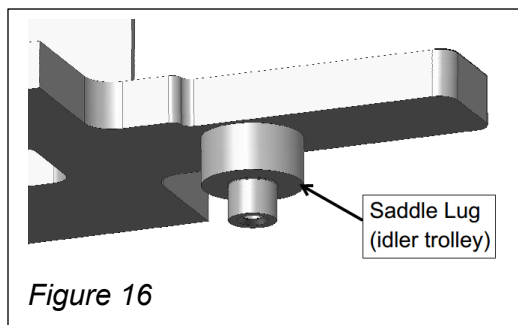
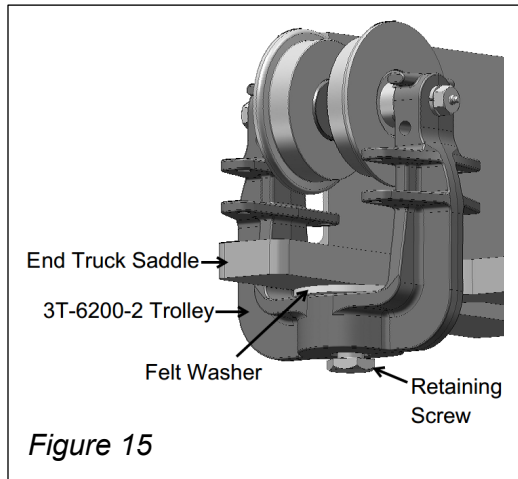
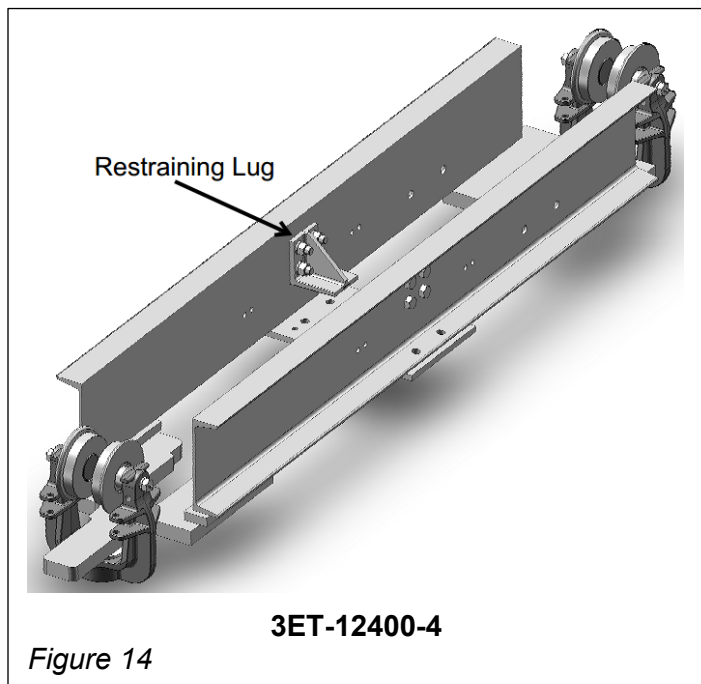
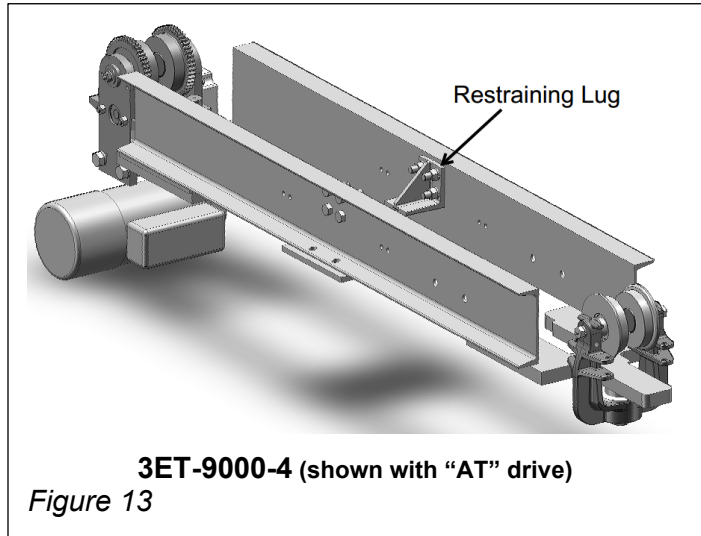

End Truck Frame Configuration – for correct location of Idler Trolleys, 3T-6200 and 3T-8000, and “A” or “AT” Model Motorized Trolleys on saddles

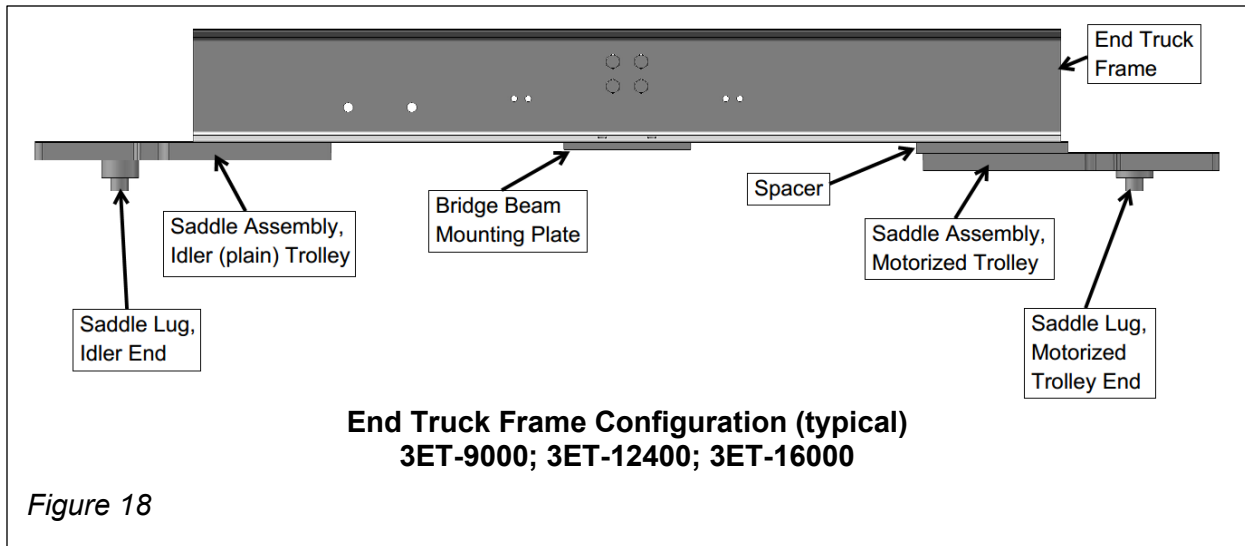

Frames for 4-wheel end trucks that may be used with an “A” or “AT” model motorized trolley are constructed as shown in Figure 18:

- One end has a Saddle Assembly built specifically to mount only an idler (or plain) trolley.
- The other end has a Saddle Assembly that may have either an idler or a motorized trolley installed on it. This end is easily identified by the spacer between the saddle assembly and the end truck frame channels.

Procedure and Option to install end trucks on rail: 3ET-9000-4 / -4SR / -4AT / -4SRAT / -4A / -4SRA
3ET-12400-4 / -4SR / -4AT / -4SRAT / -4A / -4SRA
3ET-16000-4 / -4SR / -4A / -4SRA

- a)
 1. Remove trolleys from end trucks (if shipped mounted)
 2. Place trolleys on rail
 3. Remove restraining lugs from end truck
 4. Lift crane into position under rail (top of end truck saddle must be tight to bottom of rail tee section)
 5. Place felt washer on each saddle lug
 6. Roll trolleys onto each end of end truck, verify spherical washer and thrust bearing are in place in the cavity in the base of each trolley yoke (see Figure 17)
 7. Position saddle lug (see Figure 16) into thrust bearing
 8. Install retaining screw and lock washer (see Figure 15)
 9. See *Motorized Trolley Installation Instructions* for directions to connect Motorized Trolley to saddle
 10. Reassemble restraining lugs
- b)
 1. Remove trolley wheels from each trolley yoke, leaving yokes attached to end truck frame
 2. Remove restraining lugs from end truck
 3. Lift crane into position under rail, with yokes straddling rail
 4. Reassemble trolley wheels to yokes.
 5. Reassemble restraining lugs

325 Series End Trucks

4-Wheel End Trucks

3ET-20000-4SR

Figure 19

For general end truck assembly, see Figures 19, 20, 21, and 22.

See Figure 23 for end truck frame configuration.

For directions on installing Motorized Trolleys on saddle, see *Motorized Trolley Installation Instructions*.

For installation of end truck on rail, see methods described on next page.

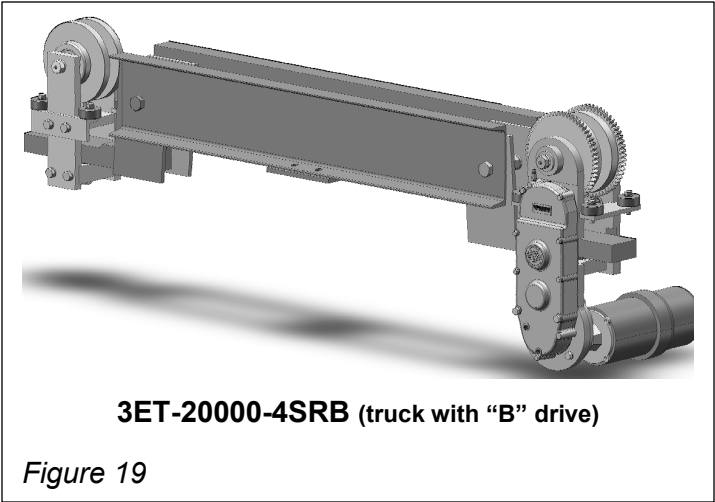

Restraining Lug Note: this model end truck uses bolts to serve as restraining lugs. See Figures 21 and 23.

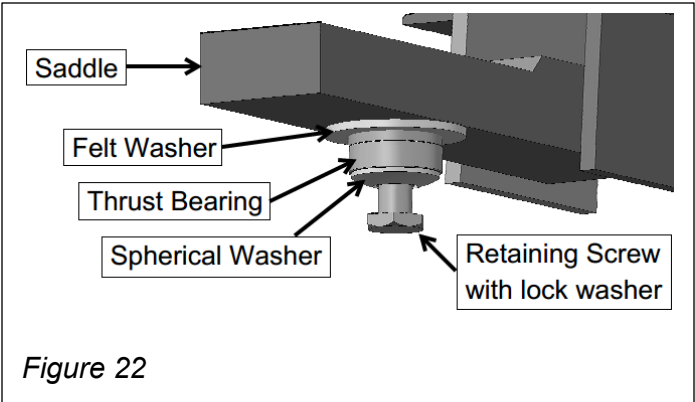
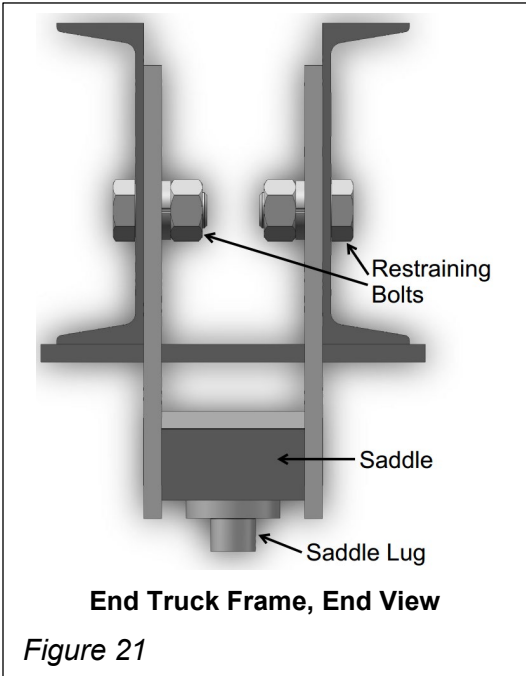
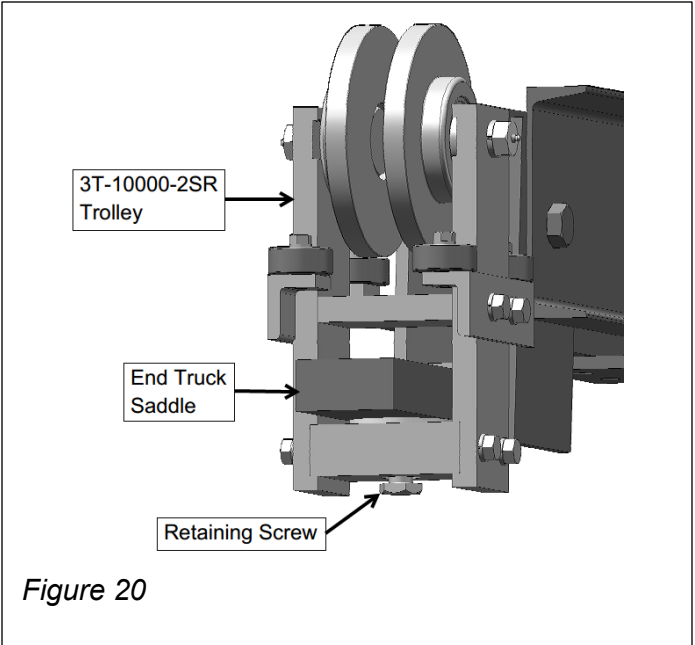

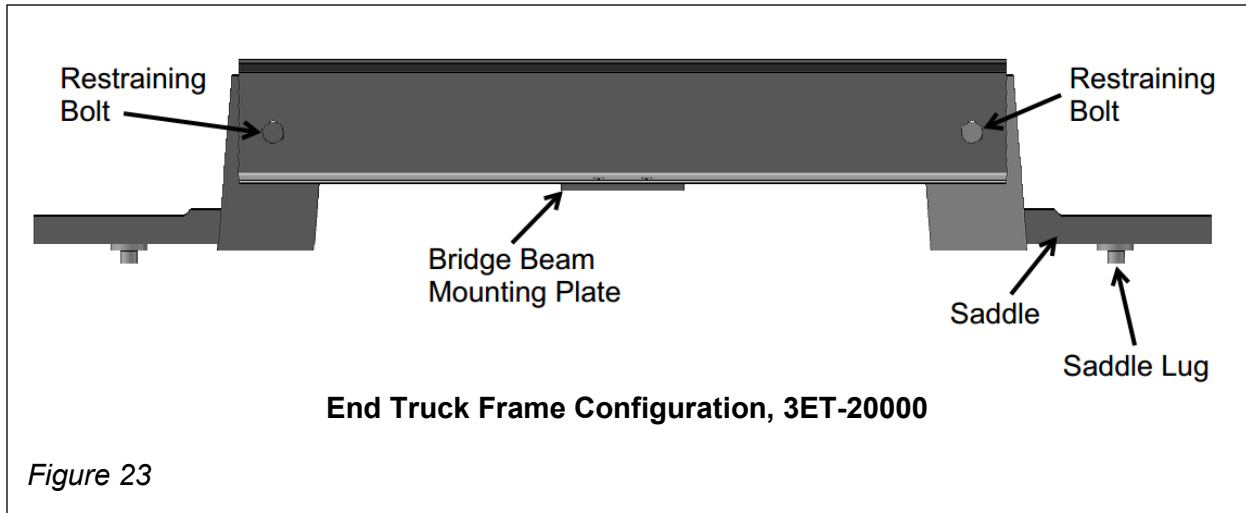

Frames for 3ET-20000 end trucks are constructed as shown in Figure 23. Both saddles on this end truck accept either an idler (plain) trolley or a “B” model motorized trolley.

Procedure and Option to install 3ET-20000-4SR or 3ET-20000-4SRB end trucks on rail:

- a)
1. Remove trolleys from end trucks (if shipped mounted)
 2. Place trolleys on rail
 3. Remove restraining bolts from end truck
 4. Lift crane into position under rail (top of end truck saddle must be tight to bottom of rail tee section)
 5. Place felt washer on each saddle lug
 6. Roll trolleys onto each end of end truck, verify spherical washer and thrust bearing are in place in the cavity in the base of each trolley yoke (see Figure 22)
 7. Position saddle lug (see Figure 21) into thrust bearing
 8. Install retaining screw and lock washer (see Figure 20)
 9. See *Motorized Trolley Installation Instructions* for directions to connect Motorized Trolley to saddle
 10. Reassemble restraining bolts
- b)
1. Remove trolley wheels from each trolley yoke, leaving yokes attached to end truck frame
 2. Remove restraining bolts from end truck
 3. Lift crane into position under rail, with yokes straddling rail
 4. Reassemble trolley wheels to yokes.
 5. Reassemble restraining bolts

325 Series End Trucks

8-Wheel End Trucks

- 3ET-24800-8 Figure 24
- 3ET-24800-8SR Not Shown
- 3ET-28000-8 Figure 25
- 3ET-28000-8SR Not Shown

For general assembly of either the 3ET-24800 or 3ET-28000 end trucks, see Figures 24 and 25.

Figure 26 shows a 4-wheel idler trolley assembly, and Figure 27 shows the arrangement of the spherical washer, thrust bearing and felt washer in the cavity or pocket of the 2-wheel trolleys for connection to the crane loadbar.

Figures 28 and 28A show a similar 4-wheel assembly with a motorized trolley. Note the bumper extension bolted to the crane loadbar...this must be in place for proper engagement to the runway end stop.

For directions on installing Motorized Trolleys on loadbar, see *Motorized Trolley Installation Instructions*.

See Figure 29 for typical end truck frame configuration.

For installation of end truck on rail, see method described on a following page.

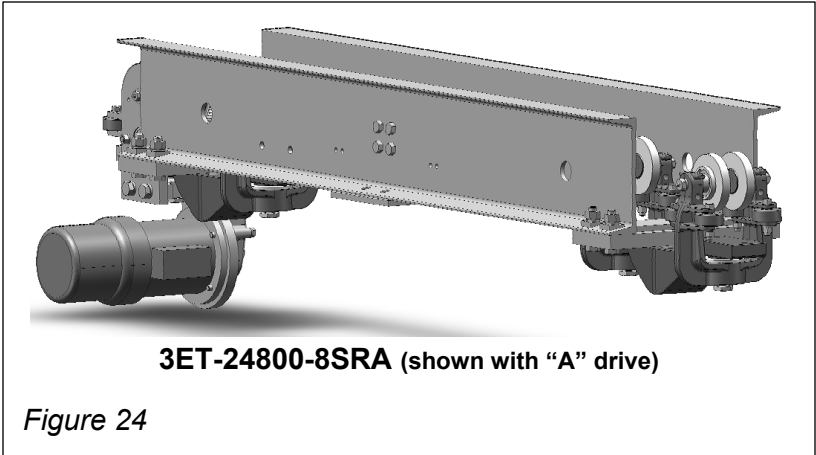

Figure 24

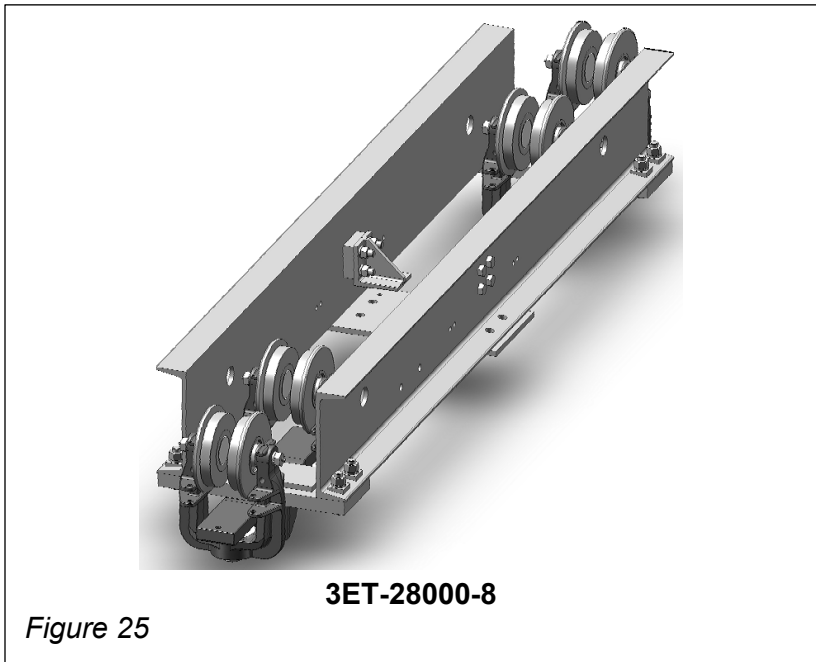

Figure 25

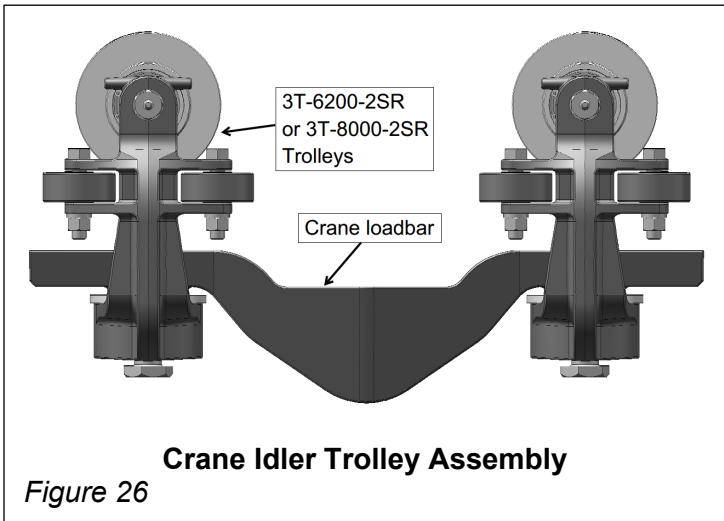

Figure 26

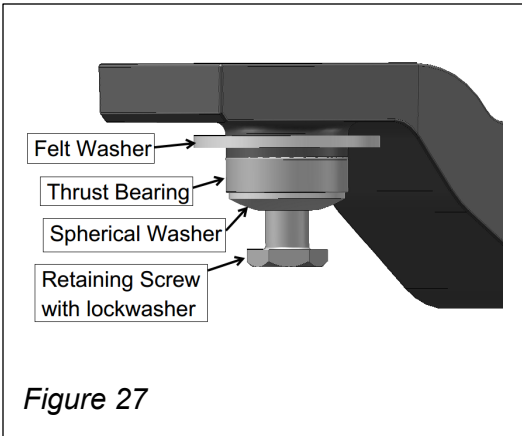
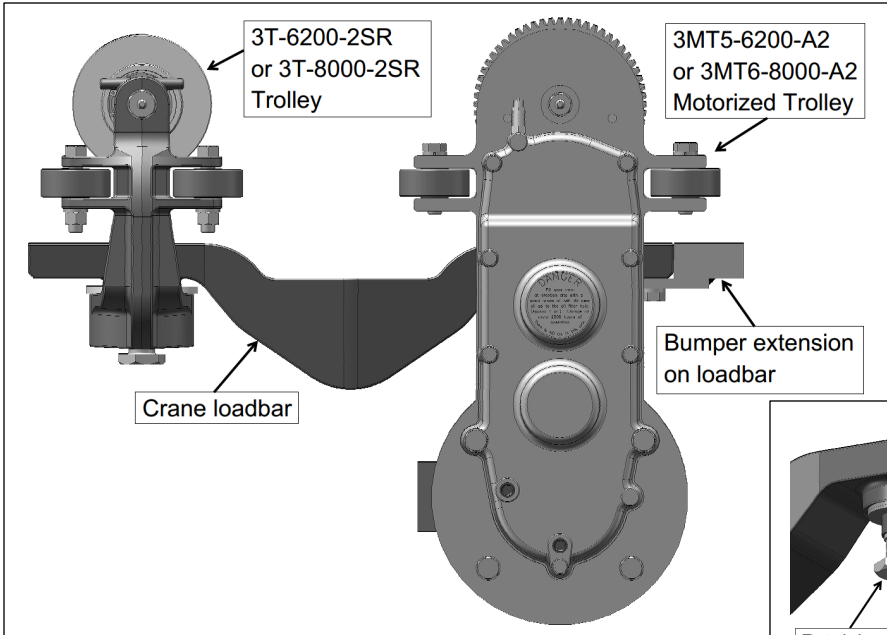

Figure 27



For more information about mounting motorized trolleys, see *Motorized Trolley Installation Instructions*.

Crane Motorized Trolley Assembly

Figure 28

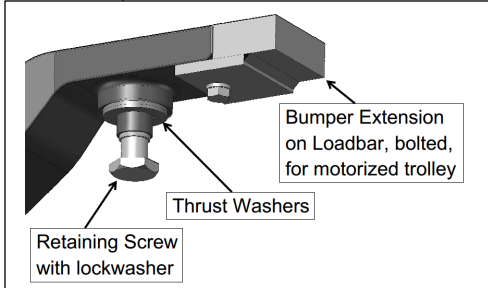
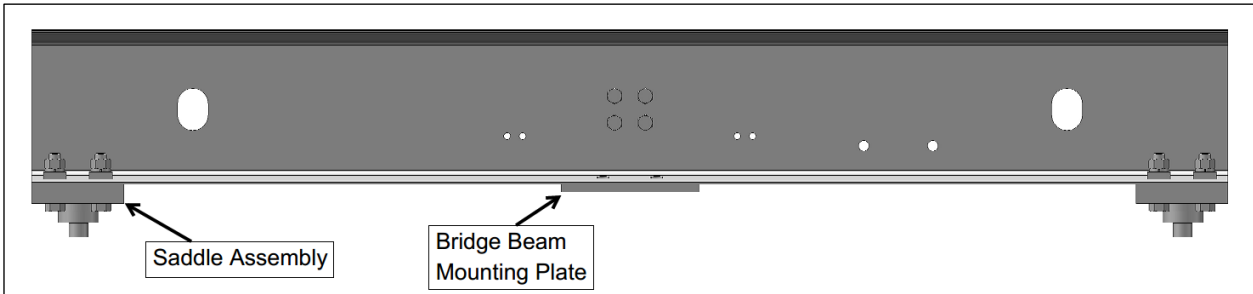

Fig. 28A



Typical End Truck Configuration, 3ET-24800 and 3ET-28000

Figure 29

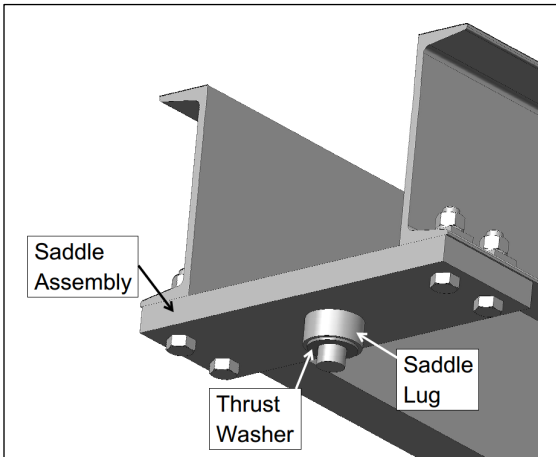

Figure 30

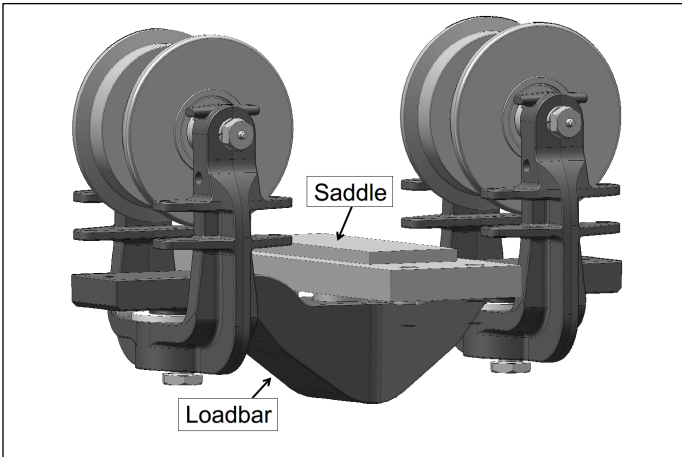

Figure 31

Procedure to install 3ET-24800 or 3ET-28000 end trucks on rail:

1. Place 4-wheel trolley assemblies on rail by threading onto rails at open end (remove end stop). If there is no open end, or no access to an open end, remove 2-wheel trolleys from crane load bar (if assembled from factory) and remove wheels from trolley yokes. Reinstall wheels when yokes have been lifted into place, straddling the riding tread of the rail. Reinstall crane load bar. Assure proper placement and orientation of assemblies with motorized trolleys. Compare to crane assembly drawing.
2. See *Motorized Trolley Installation Instructions* for directions to connect Motorized Trolley to loadbar.
3. Assure loadbar bumper extension is in place at motorized trolley.
4. Remove restraining lugs from end truck.
5. Remove saddle assemblies from end truck frames (see Figures 29 and 30).
6. Set saddle assemblies onto crane loadbars, as shown in Figure 31. Assure thrust washer is in place.
7. Lift crane into position under rail.
8. Roll 4-wheel trolley assemblies with saddle assemblies under each end of end truck.
9. Reassemble saddle assemblies to end truck frame.
10. Reassemble restraining lugs

325 Series End Trucks

8-Wheel End Trucks

3ET-38000-8SR

Figure 32

For general assembly of the 3ET-38000 end truck, see Figure 32.

Figure 33 shows a 4-wheel idler trolley assembly, and Figure 34 shows the arrangement of the spherical washer, thrust bearing and felt washer in the cavity or pocket of the 2-wheel trolley for connection to the crane loadbar.

Figures 35 and 35A show a similar 4-wheel assembly with a motorized trolley. Note the bumper extension bolted to the crane loadbar...this must be in place for proper engagement to the runway end stop.

For directions on installing Motorized Trolleys on loadbar, see *Motorized Trolley Installation Instructions*.

See Figure 36 for typical end truck frame configuration.

For installation of end truck on rail, see method described on a following page.

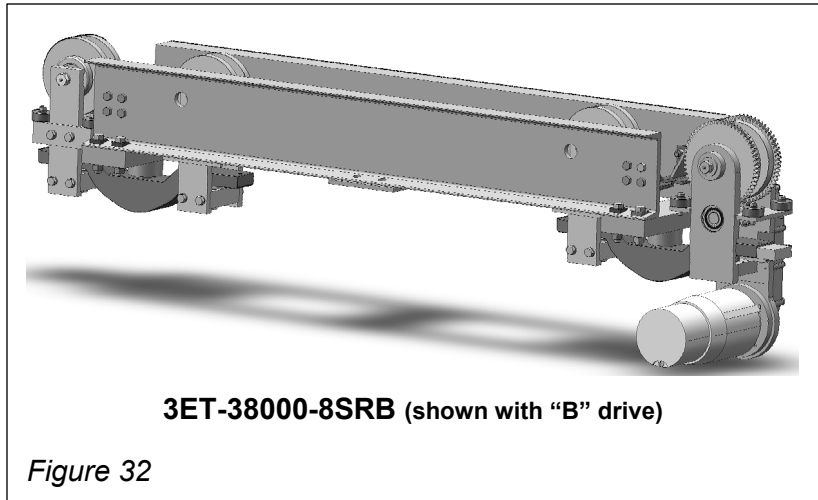

Figure 32

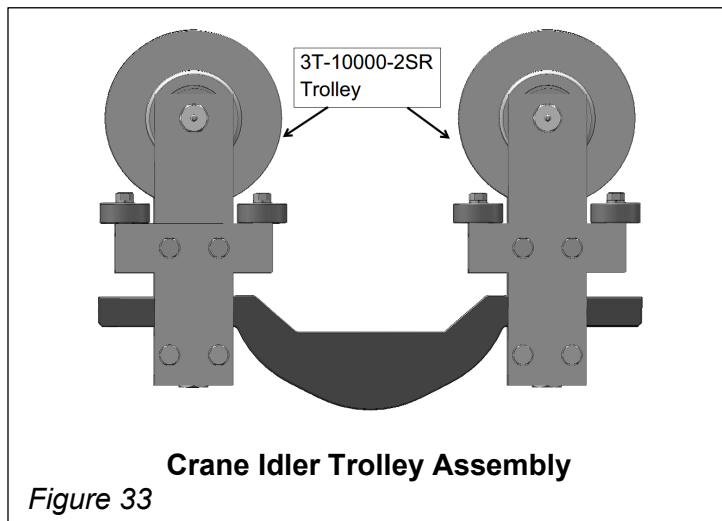

Figure 33

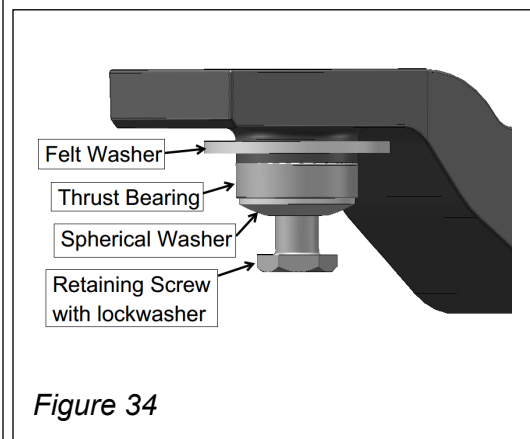
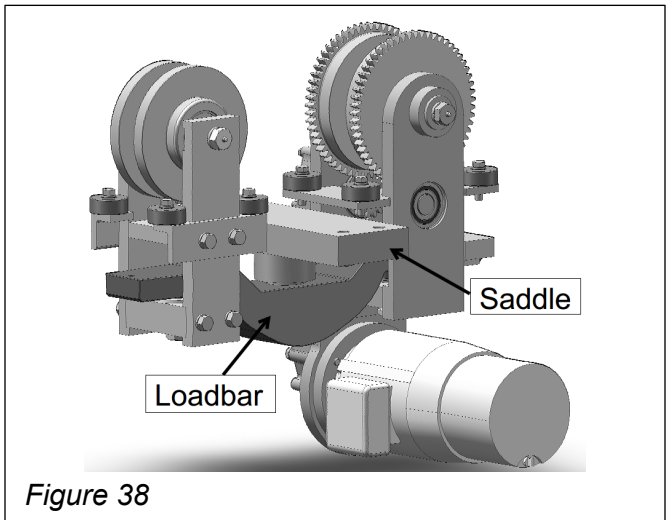
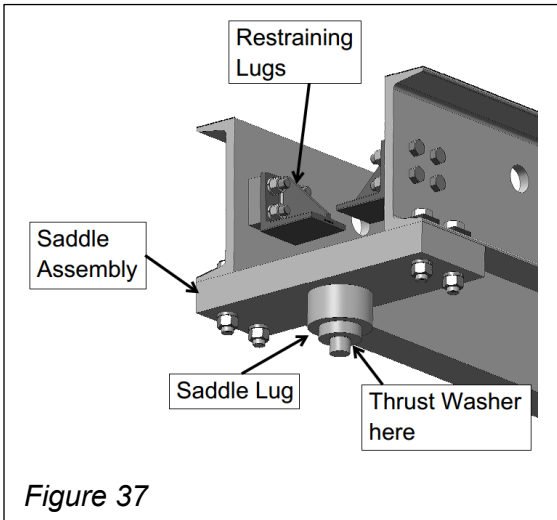
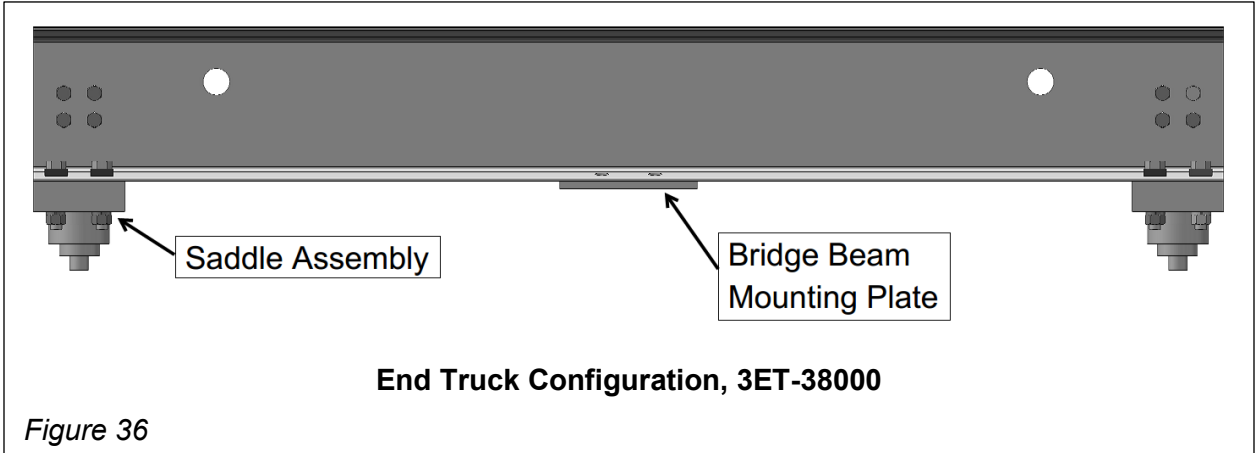
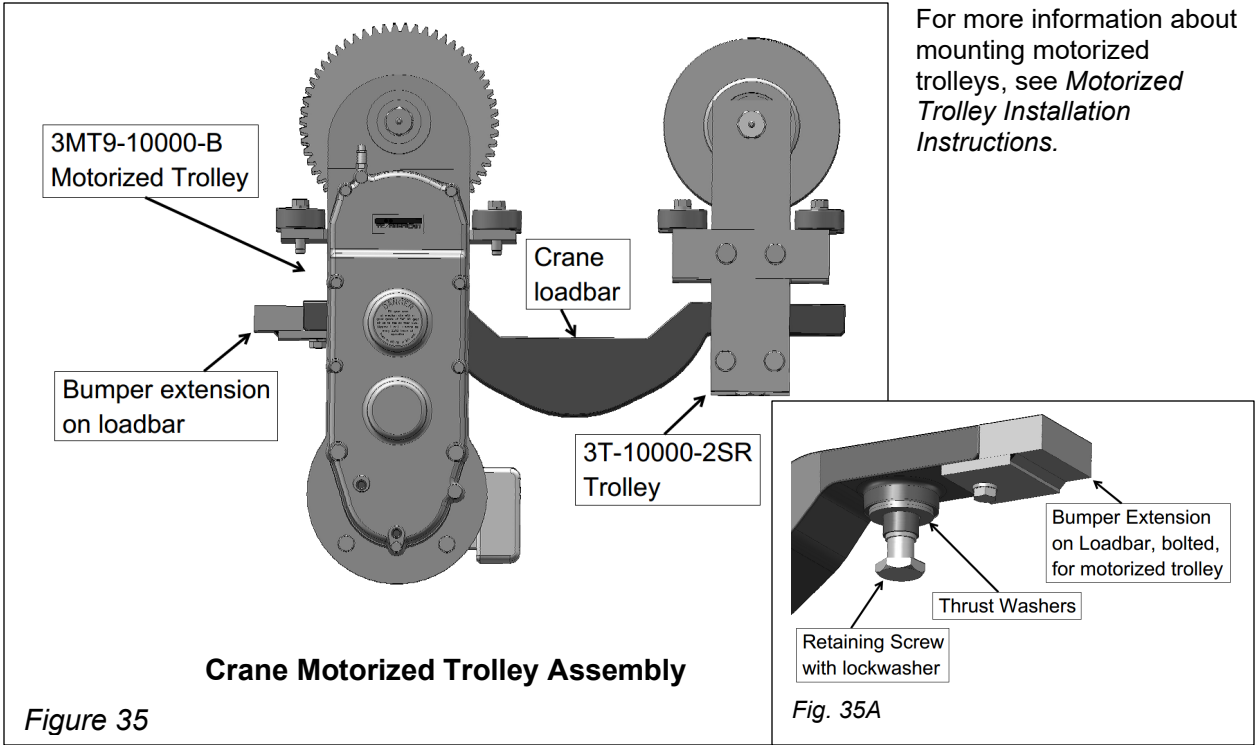

Figure 34



Procedure to install 3ET-38000 end trucks on rail:

1. Place 4-wheel trolley assemblies on rail by threading onto rails at open end (remove end stop). If there is no open end, or no access to an open end, remove 2-wheel trolleys from crane load bar (if assembled from factory) and remove wheels from trolley yokes. Reinstall wheels when yokes have been lifted into place, straddling the riding tread of the rail. Reinstall crane load bar. Assure proper placement and orientation of assemblies with motorized trolleys. Compare to crane assembly drawing.
2. See *Motorized Trolley Installation Instructions* for directions to connect Motorized Trolley to loadbar.
3. Assure loadbar bumper extension is in place at motorized trolley.
4. Remove restraining lugs from end truck.
5. Remove saddle assemblies from end truck frames (see Figures 36 and 37).
6. Set saddle assemblies onto crane loadbars, as shown in Figure 38. Assure thrust washer is in place (see Figure 37).
7. Lift crane into position under rail.
8. Roll 4-wheel trolley assemblies with saddle assemblies under each end of end truck.
9. Reassemble saddle assemblies to end truck frame.
10. Reassemble restraining lugs

Drive Tire Adjustment

Motor driven cranes with tire drives:

correct pressure of drive tire to the bottom of the patented track tee section is very important. Excessive tire pressure by over-tightening will cause tire failure and put undue stress on other components of the drive system. Inadequate tire pressure will cause the drive tire to slip, making starts and stops difficult to control.

Tire pressure adjustments should be done when the crane is fully loaded, or at the maximum typical load. This adjusting process is the same for new installations or for tires replacement on older cranes.

Start adjustment procedure with the drive tire just touching the underside of the tee section, and all pressure adjusting nuts snug (see Fig. 39, typical drive tire and bearing assembly for 325 Series end trucks). Turn the pressure nuts one full turn. Start and stop the crane. If the tires slip in either motion, adjust the pressure nuts one half turn and again start and stop the crane. If the tires slip in either direction, adjust the pressure nuts another one half turn. Continue this process until the tire does not slip at initial start or stop. Tighten the pressure nuts an additional one half turn and tighten any remaining hardware to lock in place.

Notes:

- all drive wheels must be adjusted at the same time.
- high acceleration rates may require greater tire pressure.
- bearing support assemblies may be spring loaded or direct pressure type. See drawings.
- moisture, dirt, oils from a manufacturing process, or paint on the underside of the tee section may affect the ability of a tire to resist slipping. Clean as required.

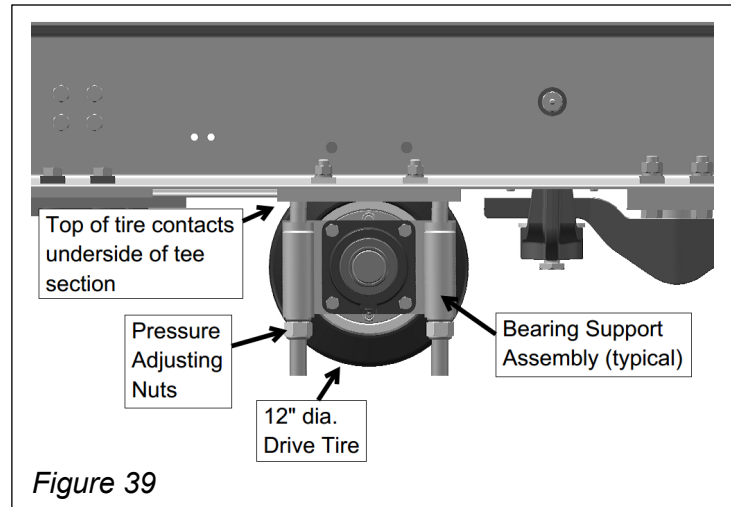

WARNING

Drive Tire Pressure Adjustment Process

Use extreme caution while performing Drive Tire Pressure adjustments. Access to the drive tire area of a crane is likely done with a manlift or similar equipment. Be sure all personnel doing the adjustments are clear of the crane before engaging the crane controls for crane movement. Persons operating the crane must have a clear view to the drive tire areas and must coordinate the method of communication between themselves and the mechanics before the process is begun.

Lubrication

General Lubrication Information

See TC/American Crane 325 Series Trolley Installation Instructions for Idler trolley lubrication and Motorized Trolley Installation Instructions for Motorized Trolley lubrication.

NOTE: before lubricating equipment that will be taken onto a customer's site, check with the customer for any preferences on brands or types (to maintain customer stock uniformity of products used and records maintenance).

NOTE: have Material Safety Data Sheet (MSDS) info available for any lubricants brought onto a work site.

NOTE: verify with customer that lubricants being used will not have an effect upon any production processes.