

Trolleys

200 Series

These instructions are for “plain” or “idler” trolleys as used on TC/American Crane 200 Series Patented Track rail.

DANGER

Lifting Operations

Installation of equipment such as TC/American Crane’s Trolleys requires performance of overhead lifting operations. Proper lifting procedures involve training, skills and experience beyond the scope of this document. Workplace supervisors are responsible to assure that all persons under their supervision are properly trained, properly equipped, and are following safety practices appropriate for the lifting operation being employed.

DANGER

Overhead Mechanical Assembly

Persons performing installation and assembly of overhead equipment must use caution while lifting, assembling and adjusting components. These operations are frequently conducted from manlifts or platforms that require specific knowledge, training and operation skills beyond the scope of this document.

Access to the floor below the work area must be restricted to reduce the potential of personnel injury due to falling objects.

Workplace supervisors are responsible to assure that all persons under their supervision are properly trained, properly equipped, and are following appropriate safety practices.

Index

Item	Page
A. General Safety Cautions	1
B. Trolley Model Numbers and Descriptions	3
C. General Installation Instructions	
D. Before Beginning Installation	4
E. Installing Trolleys on Rail	4
F. Trolleys with Electrical Collectors	4
G. Initial Start-Up	4
H. 200 Series Trolleys	
I. 2T-750-2, 2T-1150-4, 2T-750-2L, 2T-1150-4L	5
J. 2T-850-2, 2T-1200-4, 2T-850-2L, 2T-1200-4L	6
K. 2T-2000-2, 2T-2000-2L, 2T-2800-4, 2T-2000-2SR, 2T-2800-4SR, 2T-3100-4, 2T-3100-4SR, 2T-3100-4CC	7, 8,9
L. 2T-5600-8, 2T-5600-8SR, 2T-5600-8CC	10
M. 2T-3000-2, 2T-4000-4 (Crane Trolleys)	11
N. Lubrication	
O. General Lubrication Information	12
P. Lubrication Frequency	12
Q. Recommended Lubricants	12
R. Fittings	13,14

Trolleys

TC/American Crane offers several models of trolleys. Selection of the appropriate model depends upon the size of the rail on which the trolley will operate, the load to be carried on the trolley, curved or straight rail, type of fittings required, service duty class, and possibly other factors.

Trolley Model Numbers:

(general information for all trolleys)

- The first character(s) of the Model Number denotes the rail size on which the trolley operates:
 - 2 = 200 Series Rail
 - 3 = 325 Series Rail
 - 4 = 400 Series Rail
 - 45 = 450 Series Rail

- The second character, "T," identifies the product as a "Trolley."

- The intermediate numbers are the trolley capacity; i.e.:
 - 2000 = 2000 pound capacity
 - 5600 = 5600 pound capacity
 - 12400 = 12400 pound capacity
 - 16000 = 16000 pound capacity
 - etc.

- The last number, or number and letters, identify the trolley model
 - 2 = 2-wheel trolley with flanged wheels
 - 2SR = 2-wheel trolley with flangeless wheels and side rollers ("SR")
 - 4 = 4-wheel trolley with flanged wheels
 - 4SR = 4-wheel trolley with flangeless wheels and side rollers ("SR")
 - 8 = two 4-wheel trolleys connected by a secondary loadbar, with flanged wheels
 - 8SR = two 4-wheel trolleys connected by a secondary loadbar, with flangeless wheels and side rollers ("SR")
 - 2L = 2-wheel "laundry trolley" (no grease in bearings, no grease fitting)
 - 4L = 4-wheel "laundry trolley" (no grease in bearings, no grease fitting)
 - 8L = 8-wheel trolley with longer wheelbase than basic trolley
 - 4SRL = 4-wheel trolley with longer wheelbase than basic trolley
 - 8SRL = 8-wheel trolley with longer wheelbase than basic trolley
 - 2C = Crane trolley (applies only to 2T-850-2C, 3T-850-2C, 3T-2700-2C and 3T-2700-2SRC trolleys)
 - 4CC = 4-wheel, "close coupled" trolley (shorter wheelbase than basic trolley)
 - 8CC = 8-wheel, "close coupled" trolley (shorter wheelbase than basic trolley)

Trolley Part Numbers

Trolleys and Fittings are ordered and shipped by an associated computer (part) number. See the TC/American Crane Systems Catalog and Price List for part numbers.

NOTE: See the appropriate section(s) of these instructions for assembly, installation and maintenance details specific to your Trolley model.

NOTE: For a specific parts breakdown of the Trolley provided with an order, see the drawings provided with that shipment and the Trolley Section of TC/American Crane Systems Catalog.

General Installation Instructions

Before beginning the installation:

- When shipment is received, remove all shipping materials and check all parts for damage. Repair and/or replace if necessary.
- Check packing lists against materials received and identify all parts.
- Gather all TC/American Crane and other vendor equipment drawings and associated manuals (motor, reducer, brake, electrical components, etc.) as applicable and keep in a secure location for reference during installation and start-up, and to give to end user for future reference.
- Turn trolley wheels and guide rollers by hand to check for possible damage in shipment. Check for rough bearings, loose bearings and axles.
- Check electrical collectors (if provided) for condition and proper operation. Check collector wiring for routing and security.
- Store all equipment in a clean, secure area prior to final assembly.

Installing Trolleys on rail:

- Orient all components relative to their eventual position when assembled on the rail (i.e., if being used with a drivetractor, etc.).
- Trolley assemblies can be threaded onto an open end of rail (remove end stop). If there is no open end, or if obstructions or other barriers prevent access to an open end, install trolleys on the rail by removing trolley wheels from the trolley yoke (except for 2T-3000-2 and 2T-4000-4 Crane Trolleys). Reinstall wheels after the yoke is in place, straddling the riding tread of the rail.
- 2T-3000-2 and 2T-4000-4 Crane Trolleys must be installed on an open end of rail. See notes on Page 12.
- Before installing trolleys on rail, verify that appropriate fittings (stud swivels, load hooks, load eyes, etc.) are installed.
- For 2T-2000-2 or 2T-2000-2SR (plus 4-wheel or 8-wheel assemblies using these trolleys), verify that the “pocket” of the yoke (see Figure 17, Page 10) is clean and smooth, and that the head of the fittings and those on the machined load bar (see Figure 14A, Page 9) are free to pivot within the yoke. The pocket of these trolleys does not require lubrication, but a coating of good quality EP grease may be applied if desired.
- Crane end trucks or carriers may use 2T-850-2C, 2T-2000-2, 2T-2000-2SR, 2T-3000-2 or 2T-4000-4 trolleys. See *200 Series End Truck Installation Instructions*.
- Lift into position on runway or monorail and re-assemble. Use extreme caution when lifting trolleys and other equipment into place.

Trolleys with Electrical Collectors:

- For trolleys provided with electrical collectors, see *Electrical Collectors Installation Instructions*. Use extreme caution when working around electrical conductors.

Initial Start-Up:

- Operate trolleys through entire system.
- Check clearances of all portions of trolleys, fittings, load bars or other attachments or carrier structure through curves and switches.

200 Series Trolleys

2T-750-2	Figure 1
2T-1150-4	Figure 3
2T-750-2L	Figure 1A
2T-1150-4L	(not shown)

2T-750-2 and 2T-1150-4 have trolley wheel axles with grease fittings, and the bearings are greased.

2T-750-2L and 2T-1150-4L have wheels with light oil only in the bearings, and an oil port in the head of the axle bolt. Port is sealed with a plastic plug. See Fig. 1A.

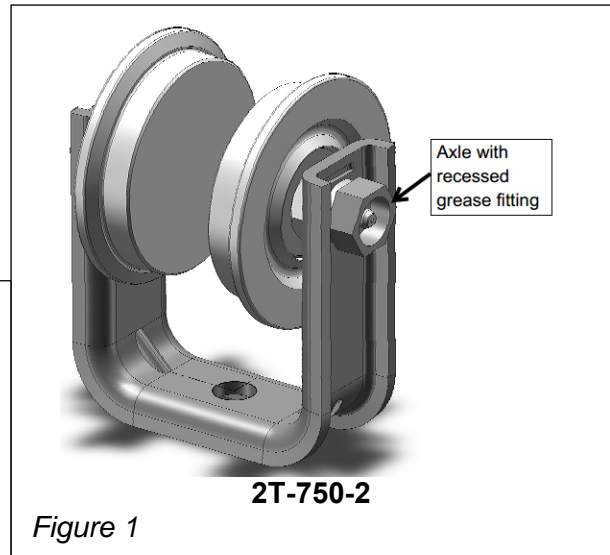
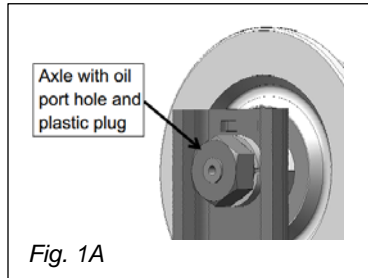

Wheel Locking Tab:

To prevent the trolley wheel hub from rotating during operation, the hex head of the wheel bushing is held by a locking tab stamped into the yoke. See Figure 2.

To mount trolley wheel to yoke, position one of the flats on the bushing against the tab as shown, then tighten wheel axle into the wheel bushing until lock washer is firmly compressed. Hold hex head of wheel bushing with 15/16" wrench, turn head of axle with 7/8" wrench (3/4" wrench for axle bolt with oil port).

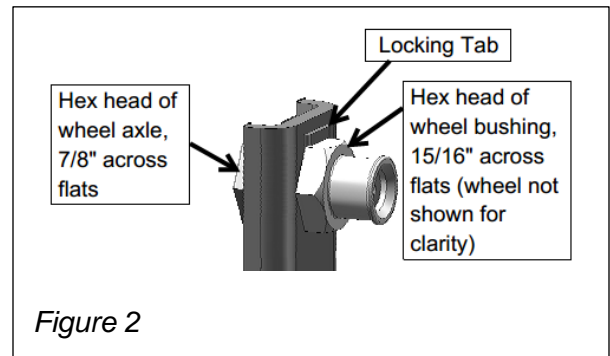

4-Wheel Trolley

The loadbar for a 2T-1150-4 or 2T-1150-4L is held in place with cotter pins, as shown in Figure 3.

For some specialized applications, the trolley loadbar may be mounted under the trolley yokes (underhung loadbar).

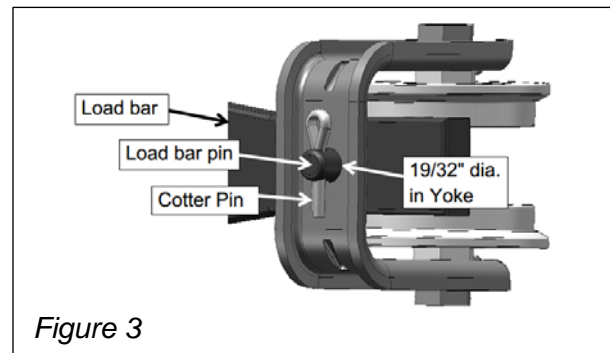

Fittings

See the Trolley Section of the TC/American Crane Systems Catalog and the Price List for fittings or load carrying devices available for these trolleys. Standard fittings include Load Eye and Load Hook. Other specialized fittings, such as laundry hooks, may also be used.

Fittings are installed either in the 19/32" hole in the bottom of the 2-wheel trolley yoke (see Fig. 3), or the 11/16" hole in the center of the loadbar of 4-wheel trolley (see Fig. 4).

See *Fittings* section of these instructions for more detail.

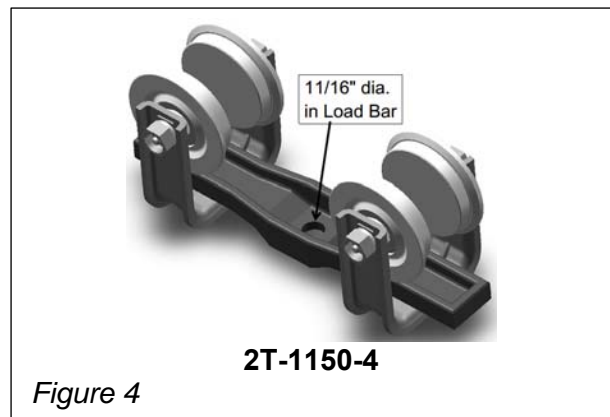

200 Series Trolleys

2T-850-2 Figure 5 **2T-850-2L** (not shown)
2T-1200-4 Figure 8 **2T-1200-4L** (not shown)

2T-850-2 and 2T-1200-4 have trolley wheel axles with grease fittings, and the bearings are greased.

2T-850-2L and 2T-1200-4L have wheels with light oil only in the bearings, and an oil port in the head of the axle bolt. Port is sealed with a plastic plug. See Fig. 5A, 2T-750-2L shown.

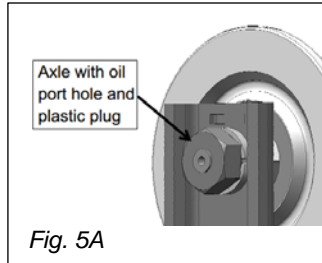

Wheel Locking Tab:

See Figure 6 (wheel hidden for clarity).

To prevent the trolley wheel hub from rotating during operation, the hex head of the wheel bushing is held by a locking tab stamped into the yoke.

To mount trolley wheel to yoke, position one flat on the bushing against the tab as shown, then tighten wheel axle into the wheel bushing until lock washer is firmly compressed. Hold hex head of wheel bushing with 15/16" wrench, turn head of axle with 7/8" wrench (3/4" wrench for axle bolt with oil port).

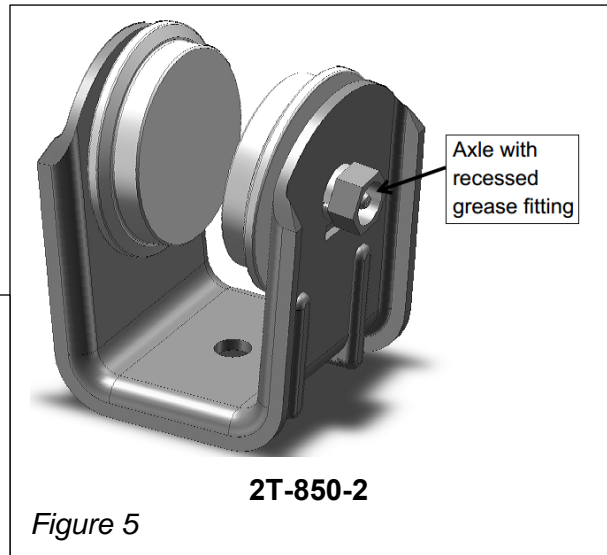

Figure 5

4-Wheel Trolley

The loadbar for a 2T-1200-4 or 2T-1200-4L is held in place with cotter pins, as shown in Figure 7. For some specialized applications, the trolley loadbar may be mounted under the trolley yokes (underhung loadbar).

Fittings

See the Trolley Section of the TC/American Crane Systems Catalog and the Price List for fittings or load carrying devices available for these trolleys. Standard fittings include Load Eye and Load Hook. Other specialized fittings, such as laundry hooks, may also be used.

Fittings are installed either in the 19/32" hole in the bottom of the 2-wheel trolley yoke (see Fig. 3), or the 11/16" hole in the center of the loadbar of 4-wheel trolley (see Fig. 8).

See *Fittings* section for more detail.

2T-850-2C Crane Trolley

Similar to 2T-850-2, as shown in Figure 5, but with an 11/16" hole in bottom of the yoke to fit load bar pin on a 2ET-1300-4 End Truck (see *End Trucks Installation Instructions*).

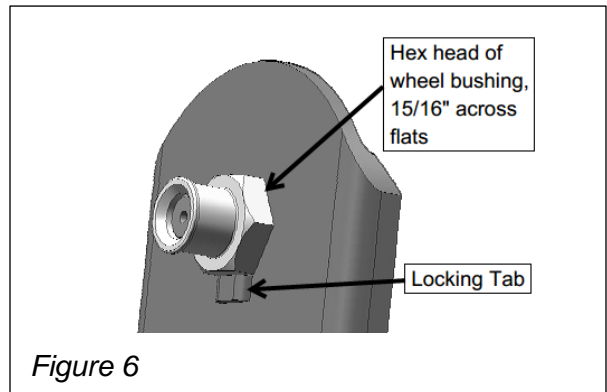

Figure 6

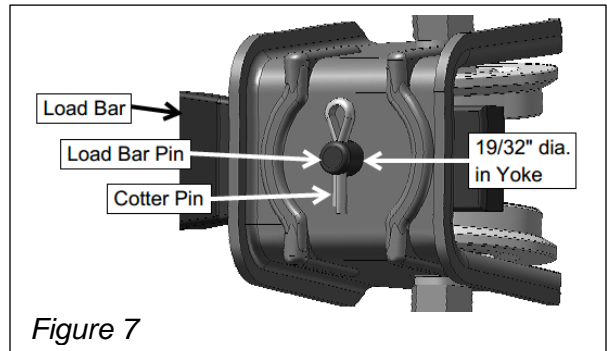

Figure 7

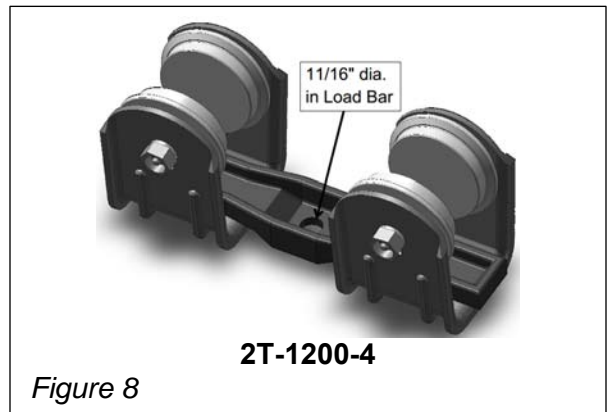

Figure 8

200 Series Trolleys

2T-2000-2	Figure 9
2T-2000-2L	(not shown)
2T-2800-4	Figure 14, Page 8
2T-2000-2SR	Figure 10
2T-2800-4SR	(not shown)
2T-3100-4	(not shown)
2T-3100-4SR	(not shown)
2T-3100-4CC	Figure 15, Page 8

The trolleys above all feature “bolt-together” yokes, as shown in Figures 9 and 10.

All trolleys except 2T-2000-2L have grease fittings recessed in end of axle as shown in Figure 11. 2T-2000-2L has wheels with light oil only in the bearings, and an oil port in the head of the axle bolt. Port is sealed with a plastic plug.

The wheel and axle is an assembly and must be replaced as a unit.

The axle is locked (prevented from turning) by the trolley yoke clamp bolts and a groove in the axle, as shown in Figure 12. This also sets the wheel-to-wheel spacing for the trolley.

Side Rollers are standard on trolleys with flangeless wheels (see Figures 10 and 13).

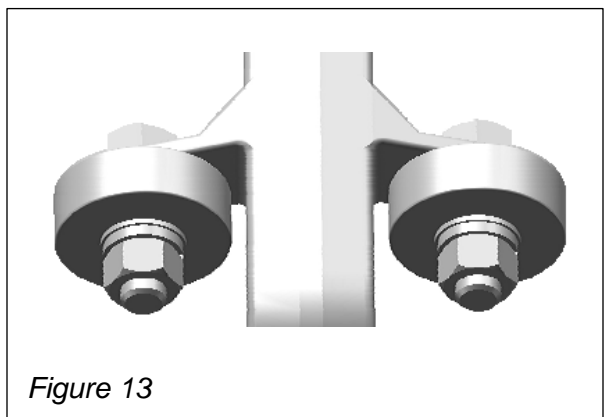
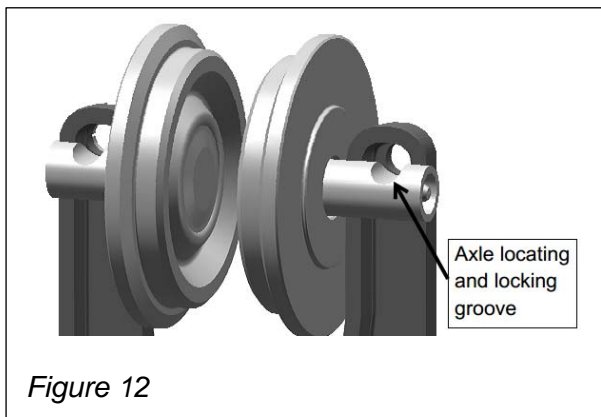
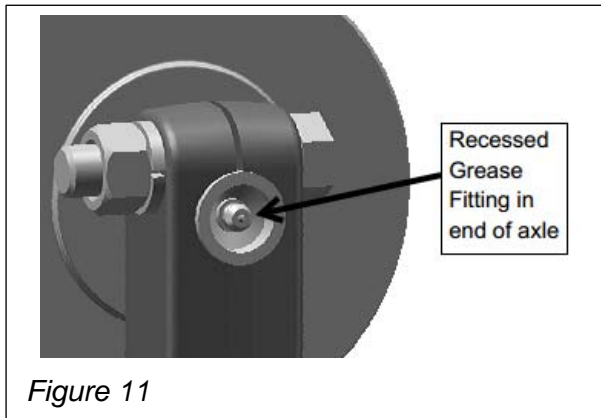

4-Wheel Trolleys

**2T-2800-4; 2T-2800-4SR;
2T-3100-; 2T-3100-4SR; 2T-3100-4CC**

Four-wheel trolleys consist of two 2-wheel trolleys, (either 2T-2000-2 or 2T-2000-2SR) coupled with a Load Bar. See example of 2T-2800-4 shown in Figure 14.

Swivel Heads on the loadbar (see Fig. 14A) are securely held in pockets of the two-wheel trolleys (see Fig. 17, Page 9).

Note: a 2T-3100-4 or 2T-3100-4SR trolley is same as a 2T-2800-4 or 2T-2800-4SR trolley, but with a 15" long loadbar in place of 11" loadbar.

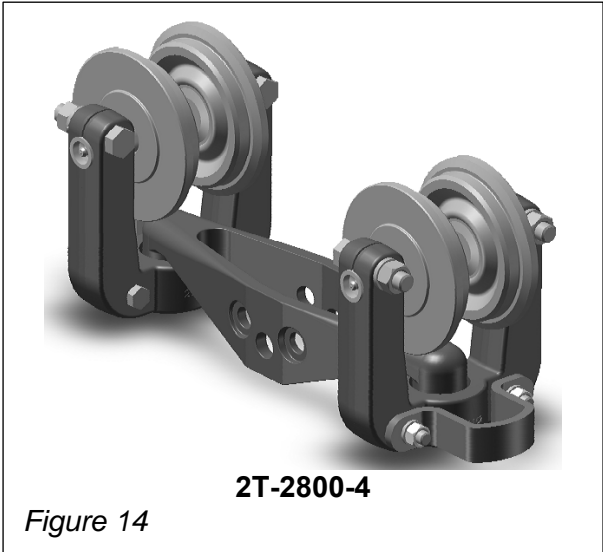

A 2T-3100-4CC trolley (see Figure 15, trolley shown with SB-213 Swivel Bushing) consists of two 2T-2000-2 trolleys coupled by a short wheelbase loadbar (6" long). This trolley is only available with the SB-123 Swivel Bushing (see Fig. 18) in the loadbar.

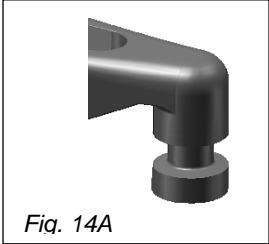

Bumpers

Four wheel trolleys only are provided from factory with bumpers at each end of the trolley (see Figure 16). Bumpers contact end stops mounted under the rail riding tread, and bumpers of other trolleys on the rail (prevents wheel-to-wheel contact).

Bumpers may also have pins for drive tractor tow bars connection welded to them (see Fig. 16A).

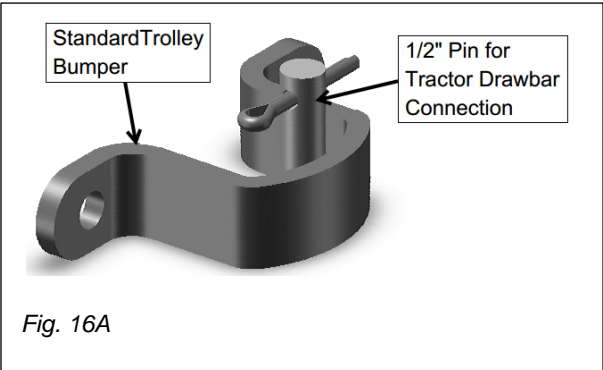
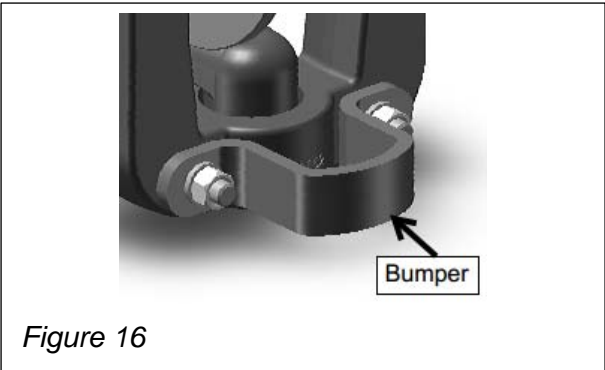
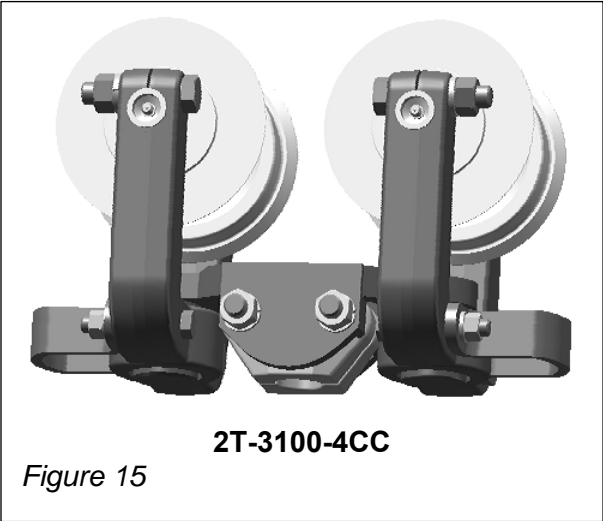

**Fittings
(for 4-wheel trolleys)**

See the Trolley Section of the TC/American Crane Systems Catalog and the Price List for all fittings (load carrying devices) available for these trolleys. Standard fittings include Load Eye, Load Hook, Stud Swivel and various other Swivels.

Other fittings, such as laundry hooks or specially designed attachments may also be used.

Fittings are mounted by containing a swivel head or a round nut on the fitting inside the machined pocket of a 2-wheel trolley yoke (see Fig. 17, yoke half), or within a similar pocket in a Swivel Bushing (see Fig. 18 and 18A, Swivel Bushing half) installed in the load bar of a 4-wheel trolley (see Fig. 19).

For hoists or other lifting devices with a top hook, a Hook Bearing (see Fig. 20) is available for the load bar (see Fig. 19). To fit the hoist hook onto the hook bearing, it may be necessary to remove the hook bearing from the load bar, sandwich the hook between the two halves, and then replace as a unit into the load bar (depends upon hook dimensions).

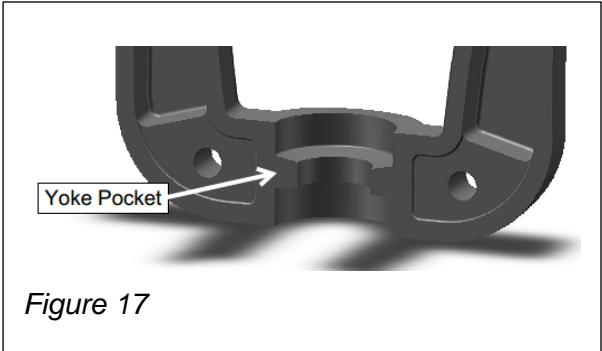

Figure 17

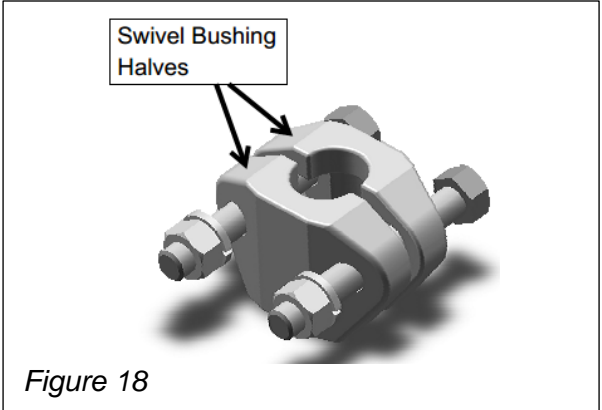

Figure 18

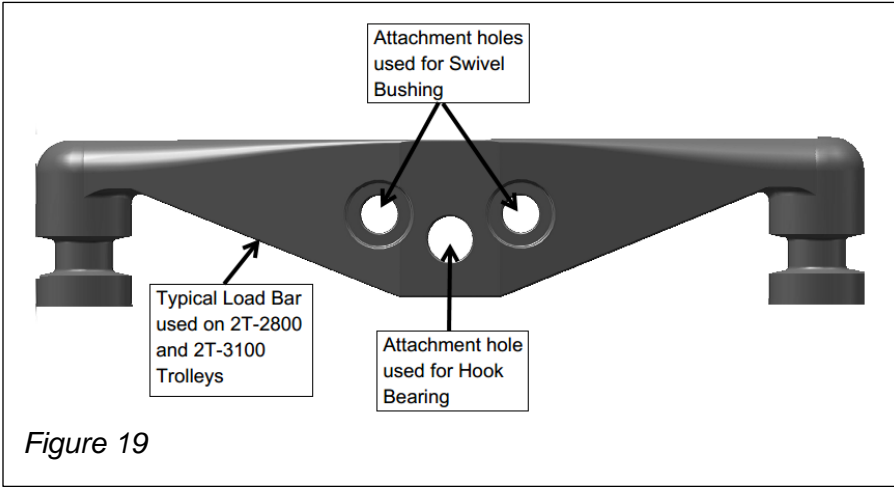
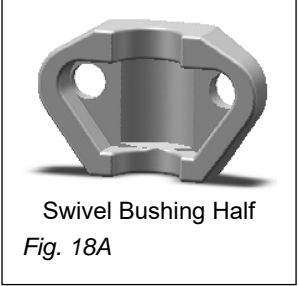

Figure 19



Swivel Bushing Half
Fig. 18A

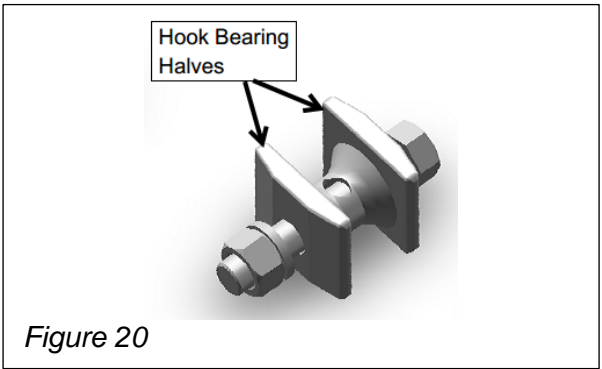

Figure 20

See *Fittings* section of these instructions for more detail.

200 Series Trolleys

8-Wheel Trolleys

2T-5600-8; 2T-5600-8SR; 2T-5600-8CC

Eight-wheel trolleys consist of two 4-wheel trolleys (either 2T-3100-4 or 2T-3100-4SR with Swivel Bushings) coupled with a Load Bar. See example of 2T-5600-8 shown in Figure 21 and a 2T-5600-8CC shown in Figure 22. These trolleys are used to distribute heavy loads on 200 Series rail.

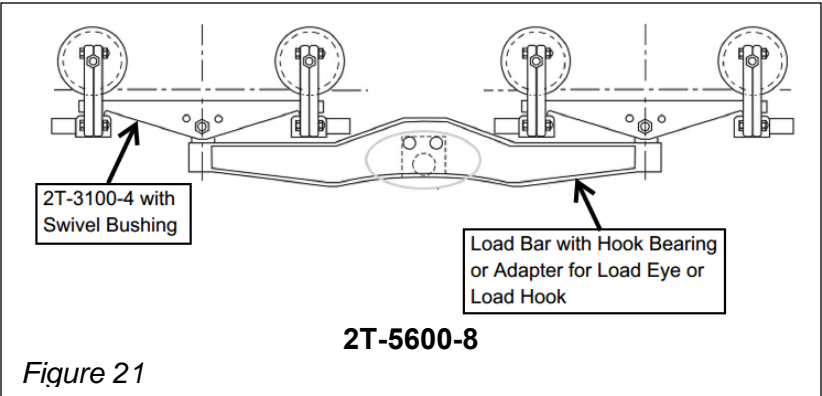

Fittings

The lower load bar on these trolleys is fitted with either a "259 Adapter" weldment for a Thrust Bearing and either an H-103 Load Hook or an E-104 Load Eye (see Figure 23), or a with a Hook Bearing (see Figure 24).

The "259 Adapter" fits over the outside of the load bar, and the Hook Bearing fits inside of the load bar weldment. To fit the hoist hook onto the hook bearing, it may be necessary to remove the hook bearing from the load bar, sandwich the hook between the two halves, and then replace as a unit into the load bar (depends upon hook dimensions).

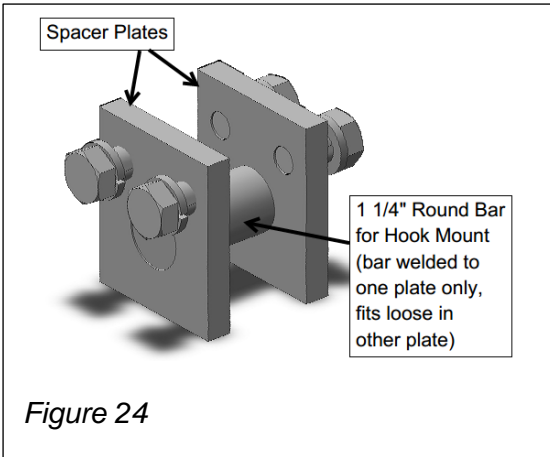
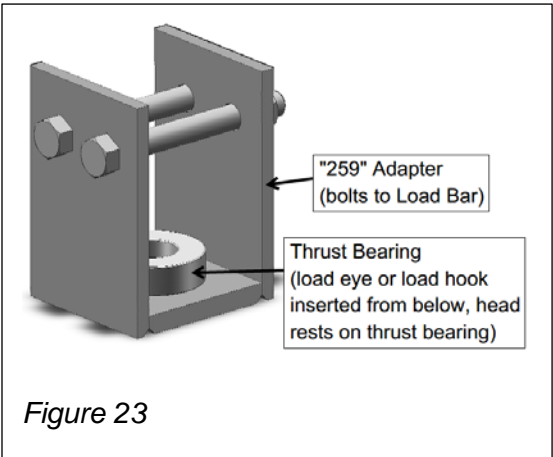
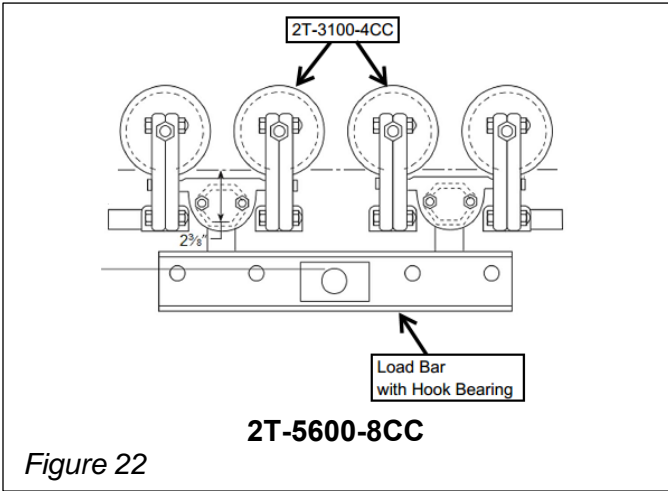

200 Series Trolleys

2T-3000-2 Figure 25

2T-4000-4 Figure 26

Note: these trolleys are crane trolleys only.

The 2T-3000-2 trolley has a single piece, cast yoke as shown in Figure 23. The wheel and axle is an assembly and must be replaced as a unit. The axle is locked (prevented from turning) by an axle clamp bolt and a groove in the axle, as shown in Figures 25 and 26. This also sets the wheel-to-wheel spacing for the trolley.

Note: because of the single piece yoke construction and the wheel/axle combination assembly, the wheel and axle assembly can only be removed from or installed in the yoke when it is off of the rail. This requires preplanning for crane handling during any crane service operations for wheel changes.

The 2T-4000-4 trolley consists of two of the 2T-3000-2 trolleys coupled by a load bar, as shown in Figure 24.

The 2T-3000-2 trolley is provided with an End Truck Pin, held in place with a cotter pin as shown in Figure 27 (trolley wheels hidden for clarity). When used in a 2T-4000-4 assembly, the End Truck Pin and Cotter Pin are not used.

For more information about mounting these trolleys on crane end trucks, see the *200 Series End Trucks Installation Instructions*.

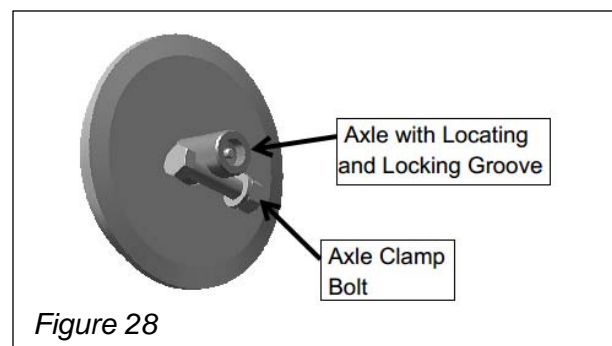
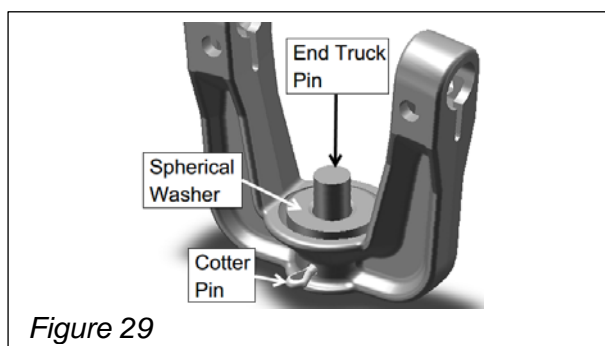
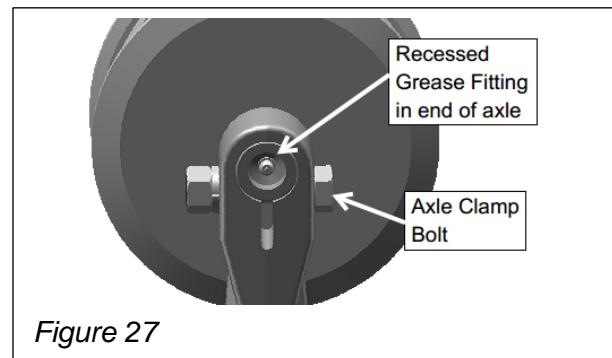
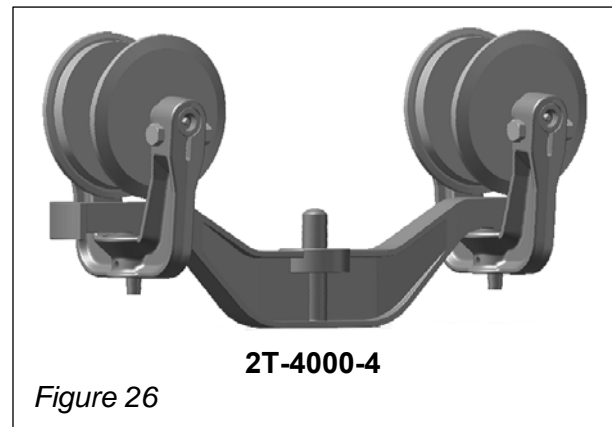
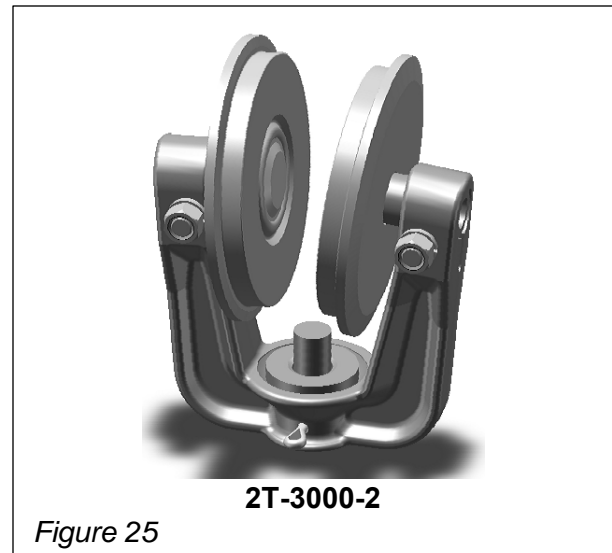

Lubrication

General Lubrication Information

1. Trolley Wheels
 - Trolley wheels with grease fittings in end of axles are packed with grease when assembled. Relubricate after use with multi-purpose lithium grease until a light film of grease appears around wheel axle. Wipe clean after greasing.
 - Trolley wheels (special order) with sealed bearings have no grease fittings and require no further lubrication.
 - Trolley wheels with oil ports instead of grease fittings have only light oil on them from our bearing supplier. Use additional light machine oil sparingly, only as required to keep the trolley wheels turning freely. Do not use excess oil that could drip onto product. Coordinate with end user regarding their preferences for oil to use.
2. Spherical Washer
 - For trolleys with a thrust washer, at installation apply a light coat of EP (Extreme Pressure) grease to the spherical washer before assembling the trolley to the load bar.
3. Yoke Pockets
 - Though not required, it is acceptable to lubricate the inside of the pocket with a light coat of EP (Extreme Pressure) grease when assembling a yoke to a load bar or a fitting.
4. Swivel Bushing
 - Though not required, it is acceptable to lubricate the inside of the swivel bushing with a light coat of EP (Extreme Pressure) grease when assembling to a fitting.
5. Side Rollers
 - Side rollers are provided with sealed bearings and require no further lubrication.

Lubrication Frequency

There is no absolute definition for periodic relubrication of TC/American Crane trolleys. Each application must be evaluated on its own merits, including: service duty, operating speed, number of operations per shift, and operating environment.

Maintenance personnel should develop and maintain a record of all monthly inspections. Frequency of lubrication may be adjusted to match operational demands, based upon inspection reports.

Recommended Trolley Lubricants

(for standard industrial operating environments)

Trolley Wheels (if regreaseable)	Good grade multi-purpose lithium grease
Trolley Wheels (with oil port in axle)	Good grade light machine oil
Spherical Washer	Good grade "EP" grease
Yoke and Swivel Bushing Pockets	Good grade "EP" grease

Note: TC/American Crane does not normally make a "brand name" recommendation for lubricants. Each customer may have a preference based upon many legitimate reasons. TC/A recommends to use a "good quality" lubricant and, when one is chosen, to not mix them.

NOTE: before applying any lubricant to equipment that will be taken onto a customer's site, check with the customer for any preferences on brands or types (to maintain customer stock uniformity of products used and records maintenance).

NOTE: have Material Safety Data Sheet (MSDS) info available for any lubricants brought onto a work site.

NOTE: verify with customer that lubricants being used will not have an effect upon any production processes.

Fittings

See Trolley Section of TC/American Crane Systems Catalog for more detail.

