

## Suspension

This is a general overview of some of TC/American Crane's suspension components. Some are used only with TC/American's 200 Series "2R3-5T" rail, but most can be used in various combinations with any of our patented track rails, as long as the load capacity of the component, or combination of components, is greater than the calculated Maximum Hanger Load (MHL).

See the Engineering Section of the TC/American Crane catalog for procedures to calculate hanger loads.

See the Suspension Section of the TC/American Crane catalog for more information and for views of components used in combinations to make a suspension assembly.

### DANGER

#### Lifting Operations

Installation of equipment such as TC/American Crane's Suspension Components requires performance of overhead lifting operations. Proper lifting procedures involve training, skills and experience beyond the scope of this document. Workplace supervisors are responsible to assure that all persons under their supervision are properly trained, properly equipped, and are following safety practices appropriate for the lifting operation being employed.

### DANGER

#### Overhead Mechanical Assembly

Persons performing installation and assembly of overhead equipment must use caution while lifting, assembling and adjusting components. These operations are frequently conducted from manlifts or platforms that require specific knowledge, training and operation skills beyond the scope of this document.

Access to the floor below the work area must be restricted to reduce the potential of personnel injury due to falling objects.

Workplace supervisors are responsible to assure that all persons under their supervision are properly trained, properly equipped, and are following appropriate safety practices.

**Index**

<b>Item</b>	<b>Page</b>
A. General Safety Alerts .....	1
B. Suspension – Catalog or Model Numbers.....	3
C. General Installation Instructions	
D.     Before Beginning Installation .....	4
E.     Installing Suspension Components in a Crane or Monorail System.....	4
F.     Terminology Notes, Rigid and Flexible Suspension .....	4
G. 200 Series Hangers.....	5
H.     2H-407, 2H-407C, 2H-470.....	5
I. Rigid Rod Hangers	
J.     H-4600, H-4600-S, H-6900, H-6900-S, .....	6
K. Rigid Rod Clamps	
L.     C-479, C-480, C-482, C-4600, C-6900.....	6
M. Flexible Suspension Hangers	
N.     H-8000, H-12000, H-20000.....	7
O. Flexible Suspension Beam Clamps	
P.     C-8000, C-12000.....	8
Q. Single Hanger Rod Assemblies.....	8
R. Double Hanger Rod Assemblies .....	9
S. Double Hanger Rod Components .....	9
T. 33,000 Pound Flexible Hanger Rod Components.....	10, 11
U. Special Hangers and Clamps.....	12

## Suspension

TC/American Crane offers several standard suspension components. Each is designed for a specific function and load capacity. Components may be combined to provide a composite assembly suitable for the load condition, the support structure and the rail on which it will be used.

### Suspension Catalog or Model Numbers:

(Note: the model numbers are a compilation of assignments over many years and by different companies, sales and engineering groups. Thus, there is a lack of full standardization.)

- The first character(s) of the Catalog or Model Number generally identifies the component by its use or function:
  - 2H = Hanger for 2R3-5T rail
  - H = Hanger
  - C = Clamp (except for the C-550, Ceiling Cleat)
  - R = Rigid Hanger Rod
  - FR = Flexible Hanger Rod
  - B = Various brackets
  - FSB = Spreader Bracket for Flexible Hanger Rods
  - SCP = Splice Cover Plate
- The second or intermediate set of characters (usually numbers):
  - Two or three digit numbers = generally arbitrary numbers without significance
  - Four or five digit numbers = load capacity
- The last character(s), if present:
  - C = For use on curve rail
  - 2 = For use with 2 hanger rods
  - A or B = Modification of standard component
  - F1 = Intermediate Hanger, Flexible Rod, two bolt attachment to rail or structure
  - F2 = Intermediate Hanger, Flexible Rod, four bolt attachment to rail or structure
  - FS = Splice Hanger, Flexible Rod, four bolt attachment to rail or structure
  - 8F = Clamp for use on 4" to 8" flange width
  - 11F = Clamp for use on 8" to 11" flange width
  - 12F = Clamp for use on 8" to 12" flange width
  - UF = Upper Hanger (used on overhead support structure)
  - LF = Intermediate Hanger (used on rail)
  - LFS = Splice Hanger (used on rail)

**NOTE: These are general installation instructions and may not address custom built components, options or modifications that may have been ordered as part of the factory built equipment.**

## General Installation Instructions

### Before beginning the installation:

- When shipment is received, remove all shipping materials and visually inspect all parts for damage. Repair and/or replace if necessary.
- Check packing lists against materials received and identify all parts.
- Gather all TC/American Crane drawings, plus any vendor equipment drawings, and keep in a secure location for reference during installation and start-up, and to give to end user for future reference.
- Store all equipment in a clean, secure area prior to final assembly.

### Installing Suspension Components in a Crane or Monorail System:

- Check layout drawings for any notes.
- Be familiar with all hanger types used for suspension.
- Each hanger is designed to handle the listed maximum capacity and is utilized in the system to the designated maximum hanger load.
- Be certain that each hanger is used at its designated point. Some systems use more than one hanger variety.
- Four types of suspension methods are: rigid stools, flexible rod, direct bolt, and direct bolt to brackets.
- High-strength rods are used on all flexible rod suspension systems.
- Do not, under any circumstances, weld or apply heat to any load carrying rod.
- All load carrying fasteners are minimum grade 5 or A325 grade. Any fasteners of a lesser grade will change the hanger or clamp capacity.
- A flat washer must be used if the diameter of the hole is greater than 1/16" above the fastener diameter or has a slotted hole.
- Each fastener must have a lock washer under its nut.
- Shimming at hanger points may be necessary to assure that the rail is installed level.
- After final leveling, at all flexible hanger rod suspension points check that spherical washers are seated properly. Tighten the set screw on each lock nut, then insert the spring pins.
- Be certain that all hanger rods are plumb (within 1°)..
- Recheck fasteners to be certain that all are secured and washers are properly placed.
- Tighten all suspension components.
- Rod suspended systems must be rigidly sway braced for stability. Sway brace materials are by others.

Note: refer also to *Patented Track Rail Installation Instructions: 200 Series, 325 Series, 400 Series and 450 Series* for additional information and instructions.

Terminology Note: these instructions, plus the TC/American Crane Systems Catalog and the Price List, refer to "rigid" and "flexible" hanger rods.

- Rigid Hanger Rods: hangers and clamps must be installed directly in line with each other and must be shimmed to be level. Rods must be plumb, to within 1° of vertical, and square to the hangers or clamps to avoid bending stress in the rod.
- Flexible Hanger Rods: these components allow the installer some latitude in locating hangers and clamps relative to the runway rail and support steel. Components may be bolted or clamped to runway top flange and support steel flanges without shimming for "out-of-level" conditions, within some limitations.

*Flexible Suspension components are not intended to provide a "free-swinging" system.*

Though a spherical seat, washer and nut system can accommodate conditions of up to 5° from plumb, this should not be used to compensate for an inaccurate installation of a crane or monorail system.

See Suspension Systems in the General Engineering section of the TC/American Crane catalog for a more detailed discussion.

## 200 Series Hangers

**Figure 1:** 2H-407 Hanger, a single piece cast hanger to be mounted into the head of 2R3-5T rail, as shown in Figure 2. Hole in top of hanger is for 5/8" rigid hangar rod.

Not Shown: 2H407C, Curve Hanger, a 2H-407 hanger modified by forming the lower flange to a 3 foot radius.

**Figure 2:** 2H-407 Hanger clamped into head of 2R3-5T rail. Rail may be ordered with hangers mounted into each piece of rail, but they will need to be repositioned to align with hanger locations. To reposition, loosen the bolts that hold the two halves of rail together and slide the hanger to the correct location. Retighten bolts when hangers are correctly located.

**Figure 3:** assembly of 2R3-5T Rail, 2H-407 Hanger, and 5/8" rigid rod.

**Figure 4:** typical suspension assembly using a C-479 or C-480 Beam Clamp, a 5/8" diameter Rigid Hanger Rod, and a 2H-407 Hanger mounted in 2R3-5T rail.

**Figure 5:** 2H-470 Hanger. Mounts in 2R3-5T rail the same as 2H-407 hangers. Top flange of hanger allows for direct bolt to overhead support steel.

**Figure 6:** typical assembly of 2R3-5T Rail and 2H-470 Hanger to support steel.

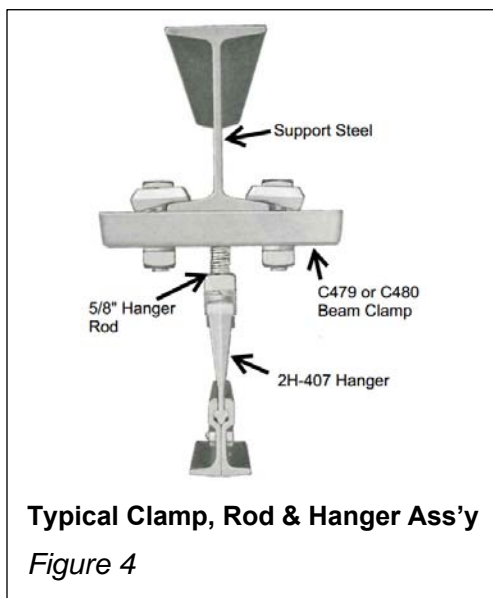
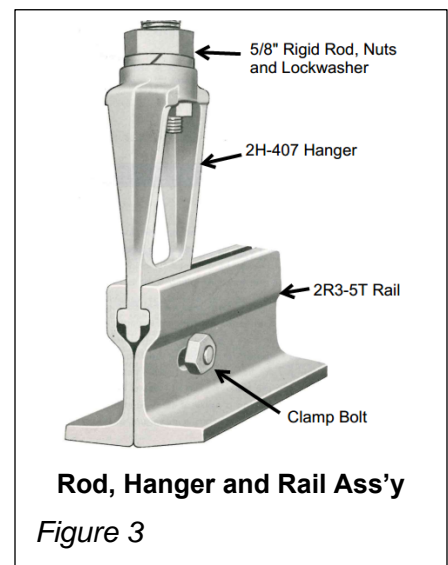

### Rigid Rod Hangers

See TC/American Crane Systems Catalog for dimensions and capacities.

**Figure 7:** “intermediate” 2-bolt hanger, used on rail at other than splice locations. Shown is H-4600, with hole for 5/8” hanger rod. H-6900 is the same hanger, but drilled to accept 3/4” rod. Hanger is mounted to rail on a “diagonal” with one bolt on each side of web.

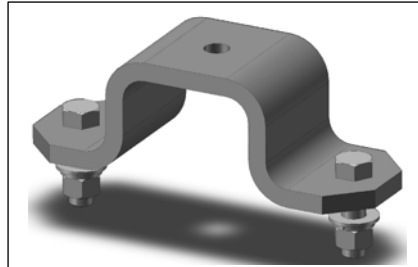

**H-4600 Hanger**

*Figure 7*

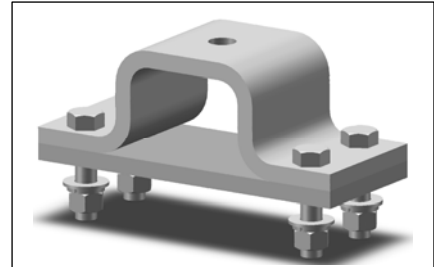

**H-6900-S Splice Hanger**

*Figure 8*

**Figure 8:** “splice” hanger, with typical 4-bolt design and splice plate. Used with 3/4” rigid hanger rod where two rails are joined together with a splice assembly. Hanger spans the joint, with two bolts in each end of each rail. Must be used with splice cover plate, included with hanger. H-4600-S is the same hanger assembly, but drilled to accept 5/8” hanger rod.



**C-479 or C-480 Beam Clamp**

*Figure 9*

Rod Dia.	Capacity
5/8”	4600 pounds
3/4”	6900 pounds

### Rigid Rod Clamps

See TC/American Crane Systems Catalog for dimensions and capacities.

**Figure 9:** typical C-479 or C-480 Beam Clamp, choice depends upon support beam flange width. Used with either 5/8” or 3/4” rigid hanger rod. Rod connected at hole in center of clamp body.

**Figure 10:** similar to other beam clamps, but higher capacity. Used with either 5/8” or 3/4” rigid hanger rods.

**Figure 11:** adjustable beam clamp for use with either 5/8” or 3/4” rigid hanger rods. Fabricated construction. Fits from 4” to 9½” flange widths (8” flange width maximum without removing one of the toes).

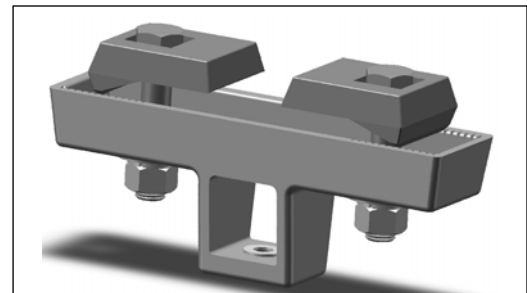

**C-482 Beam Clamp**

*Figure 10*

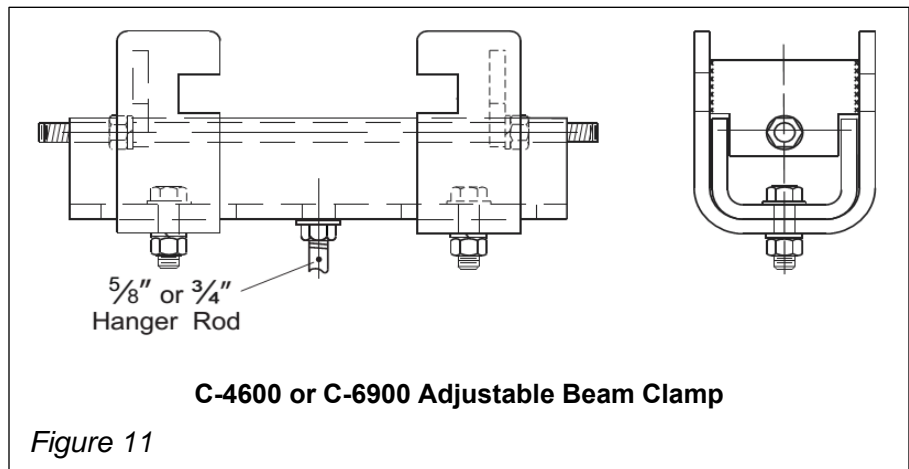

**C-4600 or C-6900 Adjustable Beam Clamp**

*Figure 11*

**Flexible Suspension Hangers**

See the TC/American Crane Systems Catalog for dimensions and capacities.

**Figure 12:** “intermediate” 4-bolt hanger, used on rail at other than splice locations. Shown is H-8000-F2, with hole for 3/4” hanger flexible rod. See TC/A catalog and select hanger model provided with bolt length appropriate for the flange thickness.

Not Shown: H-8000-F1 which is a 2-bolt hanger. See Figure 7 for a similar hanger used with rigid rod.

**Figure 13:** “splice” hanger, with typical 4-bolt design and splice plate. Used with 3/4” flexible hanger rod where two rails are joined together with a splice assembly. Hanger spans the joint, with two bolts in each end of each rail. Must be used with splice cover plate, included with hanger. See TC/A catalog and select hanger model provided with bolt length appropriate for the flange thickness.

**Figure 14:** detail of a typical spherical seat inside of a flexible rod hanger. Seats are pressed into hole in hanger and tack welded.

**Figure 15:** view of a typical assembled hanger rod, provided with two nuts and two spherical washers. Spherical washer sets into the mating surface of a spherical seat.

Dia.	Capacity
3/4”	8000 pounds
1”	12,000 pounds
1¼”	20,000 pounds

Note: standard hanger rods are provided with 6” of thread on each end, to provide for adjustment.

**Figure 16:** after system is completely aligned, leveled and braced, tighten set screw on each spherical nut and install roll pins in hole in each end of hanger rod.

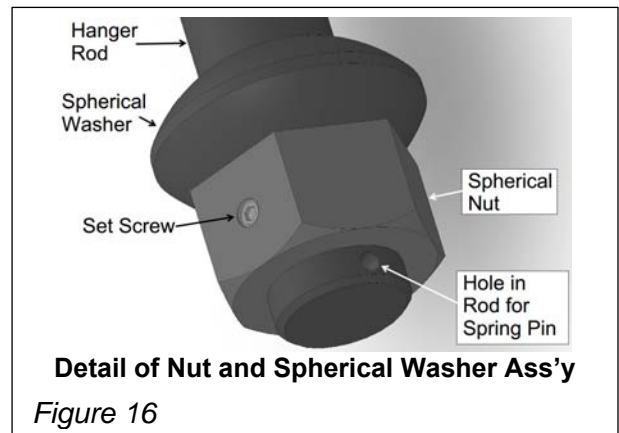
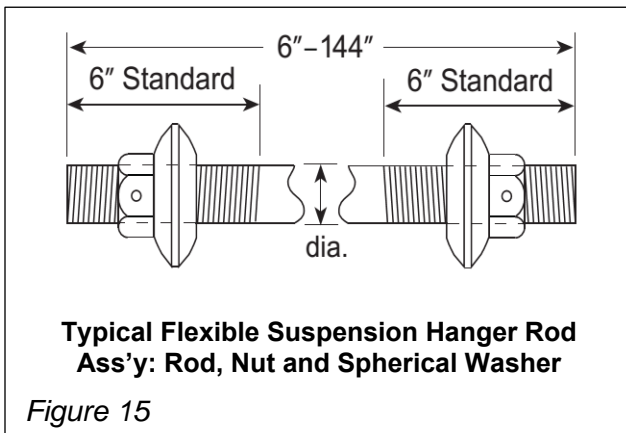
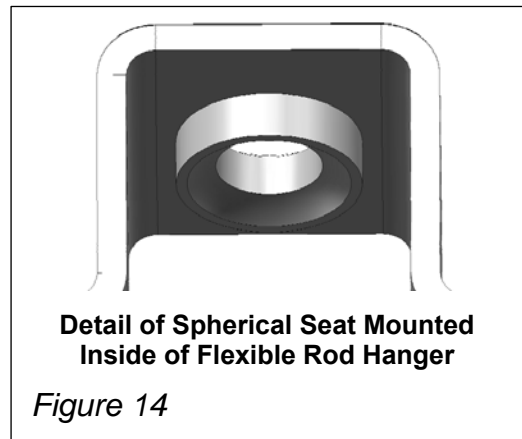
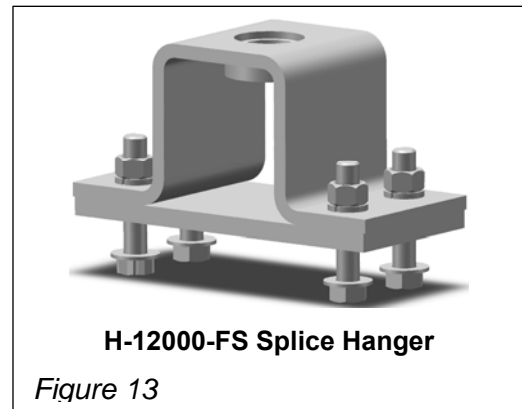
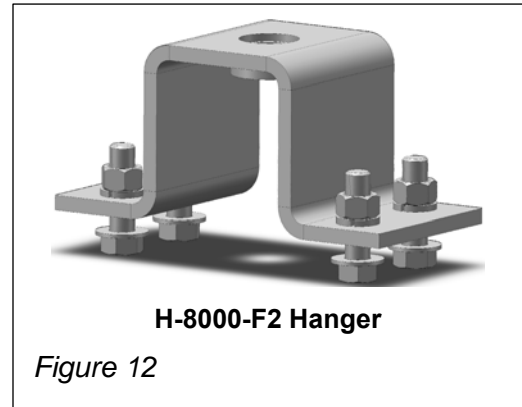

### Flexible Suspension Clamps

See the TC/American Crane Systems Catalog for models, dimensions and capacities.

**Figure 17:** adjustable beam clamp for use with either 3/4" or 1" flexible hanger rods. Fabricated construction. Models available to fit from 4" to 12" flange widths.

Not available in capacities greater than 12,000 pounds.

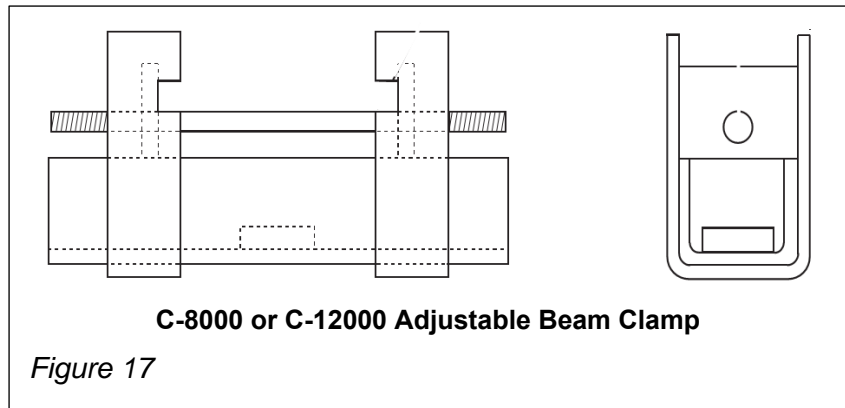

### Single Hanger Rod Assemblies

See the TC/American Crane Systems Catalog for additional information.

**Figure 18:** typical arrangement of flexible hanger rod suspension components.

Note: hangers on rail shown at a splice.

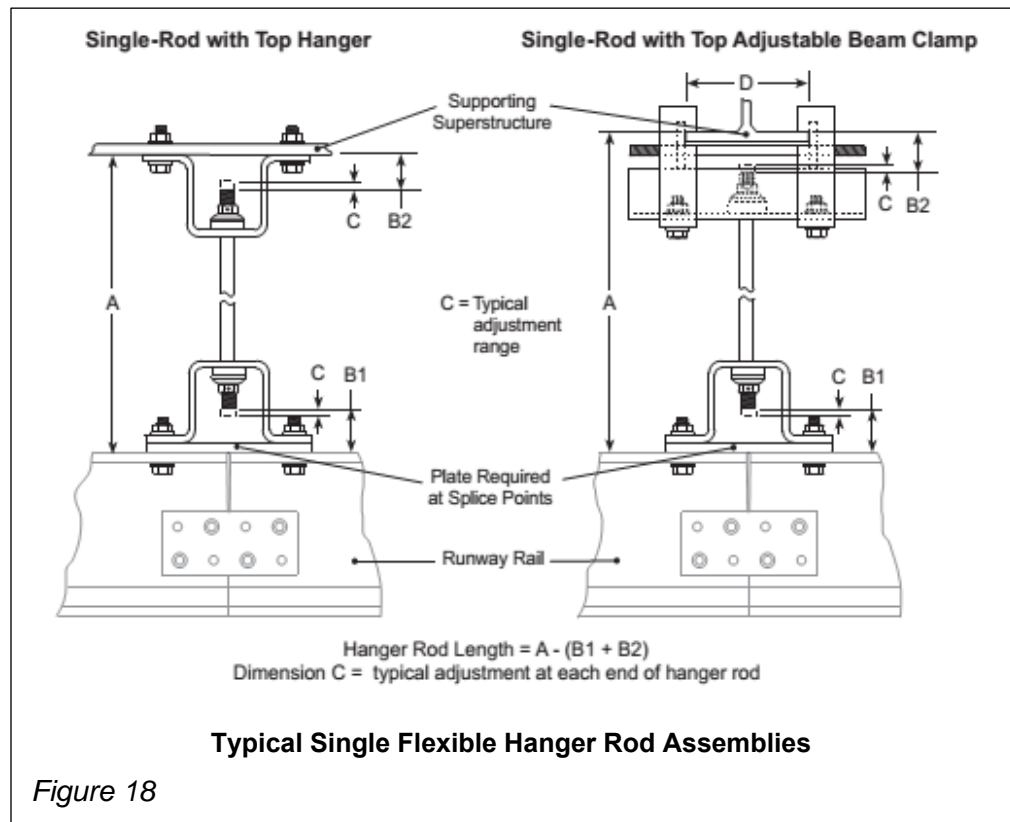



### Double Hanger Rod Assemblies

See the TC/American Crane Systems Catalog for additional information.

**Figure 19:** typical arrangement of double flexible hanger rod suspension components.

Note: hangers on rail shown at a splice. Must have splice cover plate, as shown.

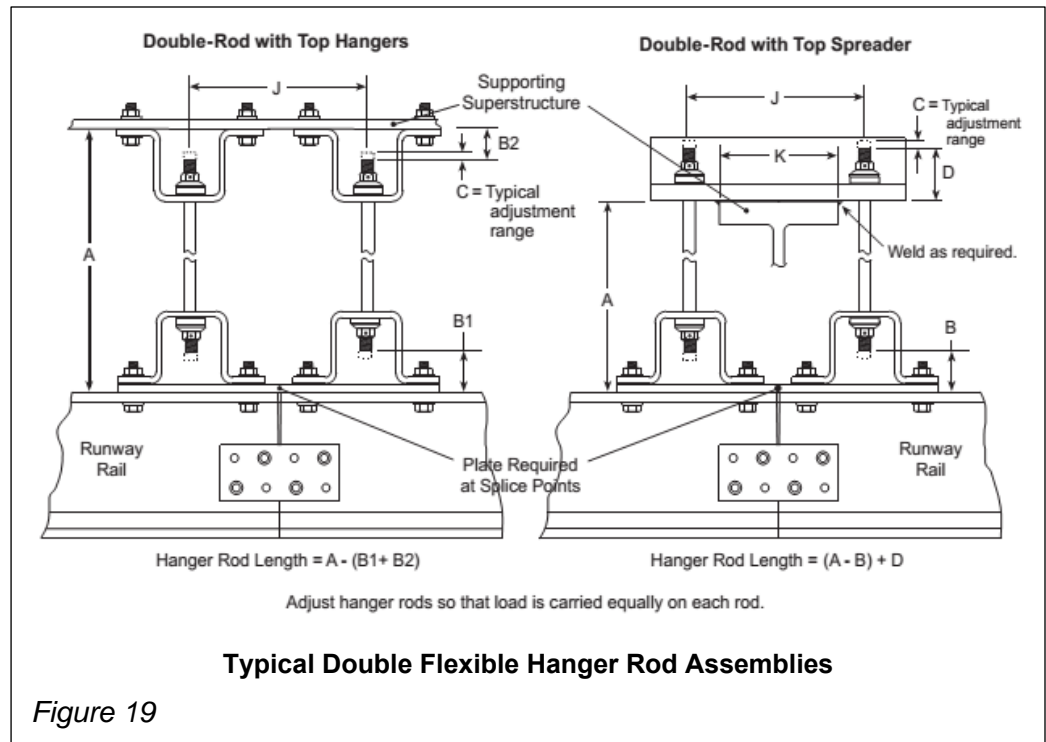

### Double Hanger Rod Components

See the TC/American Crane Systems Catalog for additional information.

**Figures 20 and 21:** examples of typical Top Spreader Brackets (see Figure 18 for application). Brackets are designed for the application and will vary, depending upon support structure dimensions and loads.

**Figure 22:** splice cover plate used with double rod suspensions. Must be used at each rail joint, as shown in Figure 18.

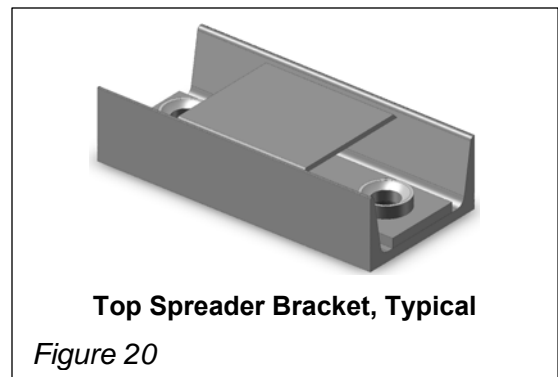

### 33,000 Pound Flexible Hanger Rod Components

See the TC/American Crane Systems Catalog for additional information. These 1½" hanger rods use a rocker nut, rocker washer and hardened seat instead of the nut, spherical washer and spherical seat of the lower capacity flexible hanger rod assemblies.

**Figure 23:** 33,000 pound hanger to be used in the "upper" position (see Figure 27). Note the Hardened Seat inside the body of the hanger.

**Figure 24:** an "intermediate" 4-bolt hanger, used on rail at other than splice locations. See TC/A catalog and select hanger model provided with bolt length appropriate for the flange thickness.

**Figure 25:** a "splice" hanger, with typical 4-bolt design and splice plate. Used where two rails are joined together with a splice assembly. Hanger spans the joint, with two bolts in each end of each rail. Must be used with splice cover plate, included with hanger. See TC/A catalog and select hanger model provided with bolt length appropriate for the flange thickness. Splice hanger assembly is the same unit as an intermediate hanger, but with the addition of the cover plate.

**Figure 26:** 33,000 pound hanger rod assembly, with rod, rocker washer and hanger nut. Note that one end has 7" of thread. Adjustments are made at this end only, at the upper hanger (see Figure 27).

**Figure 27:** typical arrangement of 33,000# flexible hanger rod suspension components.

Note: hangers on rail shown at a splice.

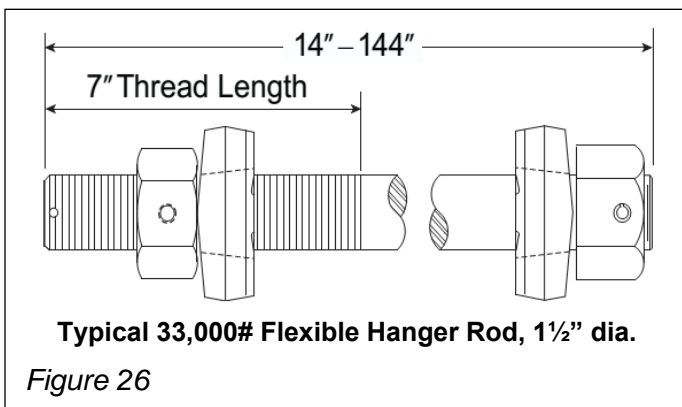
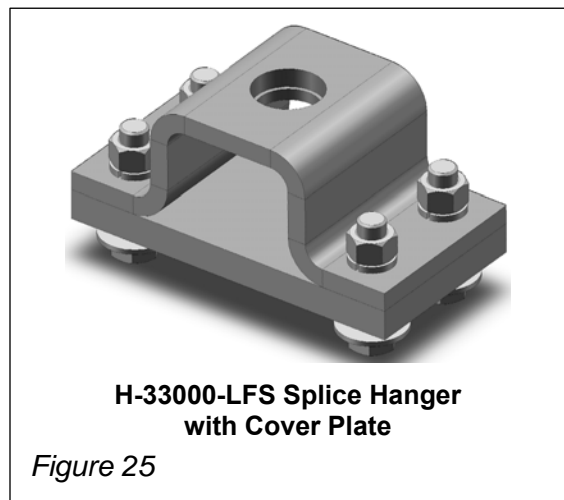
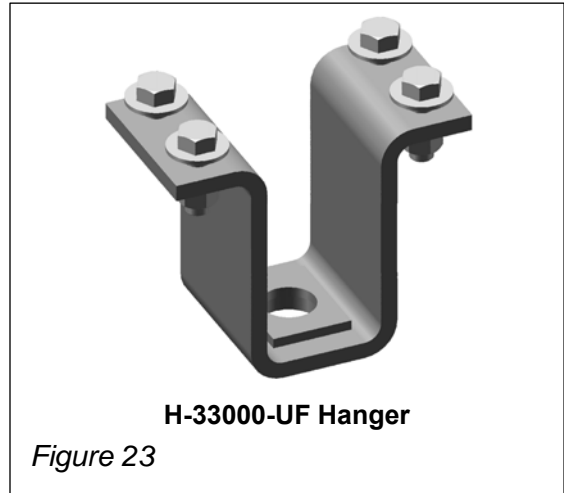

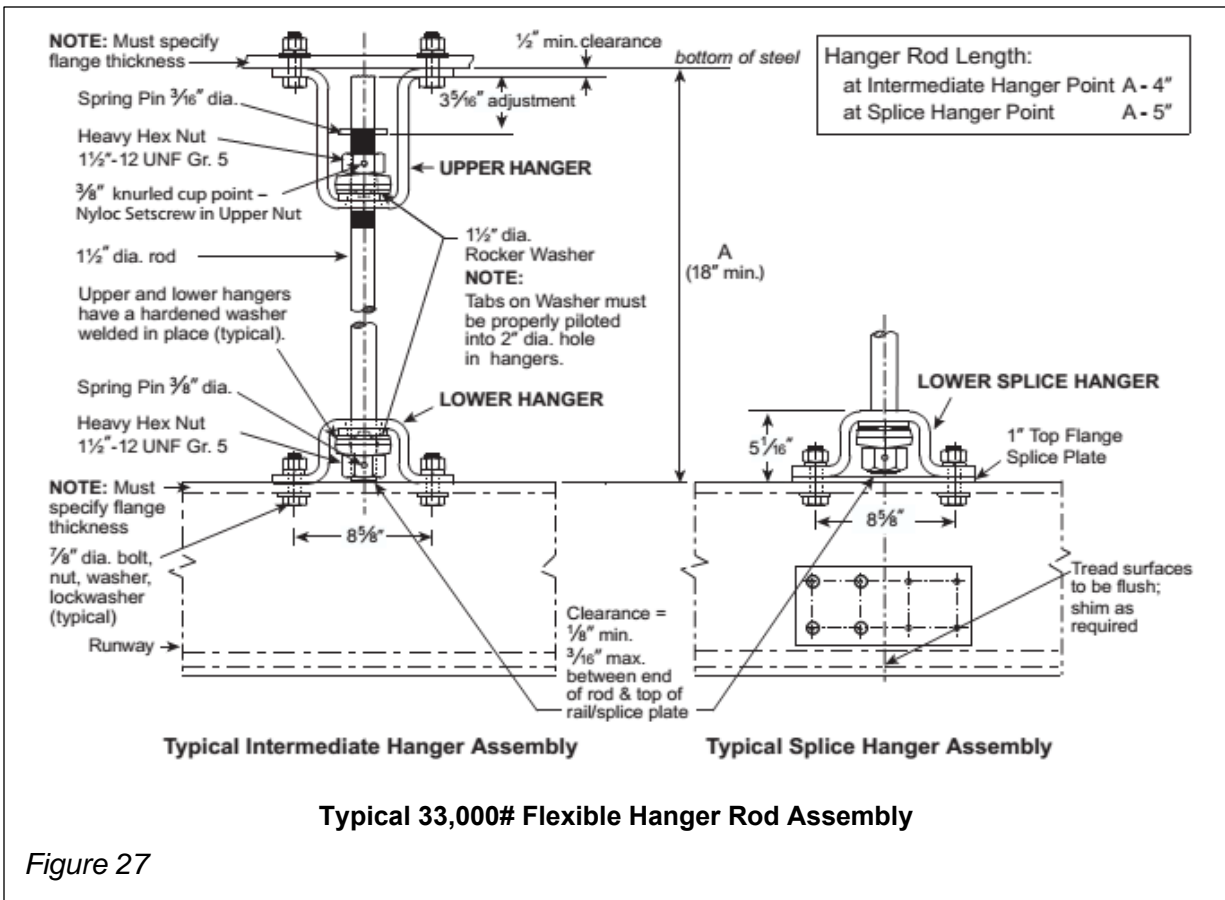

Figure 27

**Special Hangers and Clamps**

There are many TC/American Crane solutions to the problems of suspending crane runways and monorails from a building or support structure, including situations where the installer cannot drill holes in the support structure, or where structure attachment brackets were not provided.

**Figure 28:** a “C-40 Clamp” which is used to clamp a runway or monorail beam at right angle to an overhead support member. No holes are required in either the support steel or the rail top flange.

**Figure 29:** a typical “Half-Clamp” assembly. This design uses bolts through the rail top flange, and a clamp bar onto the flange of the support rail.

**Figures 30 – 33:** examples of special hanger assemblies designed to meet unique suspension requirements. Contact the sales department for assistance.

