

Interlocks – 200 Series

2I-515; 2I-930 Crane Interlock and Operating Mechanism
2I-513; 2I-850 Connecting Interlock

These instructions are for 200 Series Interlocks, Models 2I-613, 2I-615, 2I-430 and 2I -450, as used with TC/American Crane's 200 Series rail only.

An interlocking system consists of a least one crane with a Crane Interlock and Operating Mechanism and at least one spur rail with a Connecting Interlock. For some applications, the “connecting interlock” might be installed on a crane and the “crane interlock” might be installed on a spur rail.

DANGER

Lifting Operations

Installation of equipment such as TC/American Cranes and Monorails with Interlocks requires performance of overhead lifting operations. Proper lifting procedures involve training, skills and experience beyond the scope of this document. Workplace supervisors are responsible to assure that all persons under their supervision are properly trained, properly equipped, and are following safety practices appropriate for the lifting operation being employed.

DANGER

Electrical Equipment Installation, Service and Maintenance

Persons performing installation, service or maintenance activities on, near, or with equipment that is electrically powered are exposed to electrical hazards that could result in serious injury or death if proper precautions are not followed. Before performing such work, disconnect the electrical power source for the system at the disconnect device and lock it out, following appropriate Lockout/Tagout (LOTO) procedures, to prevent electric power from being applied while work is being performed.

All persons must use safe work practices appropriate to the electrical system, and follow all workplace procedures and policies. This requires specific knowledge, equipment and training beyond the scope of this document. Workplace supervisors are responsible to assure that all persons under their supervision are properly trained, properly equipped, and are following appropriate safety practices.

Index

<u>Item</u>	<u>Page</u>
A. General Safety Alerts	1
B. Interlocks – Model Numbers and Descriptions.....	3
C. General Installation Instructions	
D. Terminology	4
E. Overview	5
F. Before Beginning Installation	5
G. Installing Cranes and Spur Rails in an Interlocking System	5
H. Initial Start-Up	5
I. 200 Series Interlocks	
J. General Views: Crane-to-Spur; Crane-to-Crossover-to-Crane.....	6
K. 2I-515; 2I-930, Crane Interlock with Manual Operating Mechanism.....	7, 8
L. Interlock Operating Mechanism.....	9
M. 2I-513; 2I-850, Connecting Interlock	10
N. 2I-515 Crane Interlock and 2I-513 Connecting Interlock Internal Components and Operation	11
O. 2I-930 Crane Interlock and 2I-850 Connecting Interlock Internal Components and Operation	12
P. Views of Interlock Bolts, Auxiliary Bolts, and Interlock Shafts.....	13
Q. Interlock Operation	14
R. Interlock Adjustments	14
S. Procedure for Interlock Butterfly and Interlock Shaft Replacement	15
T. Lubrication	16

Interlocks

TC/American Crane offers several models of interlocks, for all sizes of our rail. Selection of the appropriate model depends upon the rail being used, load capacity of the crane and monorail, service duty class, and other factors.

Interlock Model Numbers:

(general information for all interlocks)

- The first character(s) of the Model Number identifies the rail size used with this interlock:
 - 2 = 200 Series Rail
 - 3 = 325 Series Rail
 - 45 = 450 Series Rail

Note: for 400 Series Rail, contact the factory
- The second character:
 - I = Interlock
- The number, or number and letter pair, identify a model series:
 - 513 = 200 Series, Connecting Interlock
(for 7" deep rail, for non-electrified or Bottom Contact electrification)
 - 515 = 200 Series, Crane Interlock and Operating Mechanism
(for 7" deep rail, for non-electrified or Bottom Contact electrification)
 - 850 = 200 Series, Connecting Interlock
(for 11" deep rail, for non-electrified and either Side or Bottom Contact electrification)
 - 930 = 200 Series, Crane Interlock and Operating Mechanism
(for 11" deep rail, for non-electrified and either Side or Bottom Contact electrification)
 - 613 = 325 Series, Connecting Interlock
(for 3RL8-18 rail, for non-electrified or Bottom Contact electrification)
 - 615 = 325 Series, Crane Interlock and Operating Mechanism
(for 3RL8-18 rail, for non-electrified or Bottom Contact electrification)
 - 450 = 325 Series, Connecting Interlock
(for 3RL13-27 or 3RL14-35 rail, for non-electrified or with either Side or Bottom Contact electrification)
 - 430 = 325 Series, Crane Interlock and Operating Mechanism
(for 3RL13-27 or 3RL14-35 rail, for non-electrified or with either Side or Bottom Contact electrification)
 - 9A = 325 Series, Crane Interlock and Operating Mechanism
(for mounting in 3RH14-41 rail, for non-electrified or with either Side or Bottom Contact electrification)
 - 9B = 325 Series, Crane Interlock and Operating Mechanism
(for mounting in 3RH16-47 rail, for non-electrified or with either Side or Bottom Contact electrification)
 - 9C = 450 Series, Crane Interlock and Operating Mechanism
(for mounting in 45R20-79 rail, for non-electrified or with either Side or Bottom Contact electrification)
 - 10A = 325 Series, Connecting Interlock
(for mounting in 3RH14-41 rail, for non-electrified or with either Side or Bottom Contact electrification)
 - 10B = 325 Series, Connecting Interlock
(for mounting in 3RH16-47 rail, for non-electrified or with either Side or Bottom Contact electrification)
 - 10C = 450 Series, Connecting Interlock
(for mounting in 45R20-79 rail, for non-electrified or with either Side or Bottom Contact electrification)

NOTE: See the appropriate section(s) of these instructions for assembly, installation and maintenance details specific to your Interlock model.

NOTE: For a specific parts breakdown of the Interlock provided with an order, see the drawings provided with that shipment.

General Installation Instructions

Terminology

The following instructions may use the following terms. For more information, please see the Crane Interlocks section of the TC/American Crane Catalog.

- “Crane Interlock” – components of an interlock system typically installed on an end of a crane bridge beam, including a manually operated mechanism to engage or disengage the Crane Interlock to a Connecting Interlock on a Spur Rail or the bridge beam of an adjacent crane. May be installed on one or both ends of a crane bridge. Some interlocks may be provided with an optional motorized operating mechanism. For some applications, the “crane interlock” might be installed on a spur rail, and the “connecting interlock” might be installed on a crane. Double girder cranes must have interlock components installed on each crane bridge, and on each mating bridge or spur rail.
- “Connecting Interlock” – components of an interlock system typically installed on an end of a spur rail or an adjacent crane, and designed to mechanically engage or disengage with the Crane Interlock as desired. For some applications, the “connecting interlock” might be installed on a crane, and the “crane interlock” might be installed on a spur rail.
- “Spur Rail” – a length of monorail perpendicular to the crane runway and aligned with the bridge beam. The end of the monorail adjacent to the runway is supported by the runway with a Spur Support Bracket; other monorail supports are typical suspension components. Spur rails may be extended to include curves and switches as required for the system layout.
- “Spur Support Bracket” – a unique support bracket for the end of a spur rail; also known as a “gooseneck” bracket. One end of the bracket is bolted to the top flange of the runway rail, the other end to the top flange of the spur rail. Spur support brackets assure that alignment of the crane bridge treadline is maintained relative to the spur rail, even when the runway or spur rail deflects from loading.
- “Crossover Section” – a short section of monorail (or double rails for double girder cranes) located between and perpendicular to adjacent crane runway systems. Each end of the crossover monorail is supported by a bracket similar to a spur support bracket. Each end of the monorail is typically provided with a connecting interlock. Crossover sections are used when crane-to-crane interlocking is not possible or desired.
- “Runway Deflection” – vertical movement of the runway rail between support points. See the Engineering Section of the TC/American Crane Systems Catalog for methods of calculation and selection of appropriate rails. Runway rail at spans where interlocking will take place are generally sized for less deflection than the rail in other spans, therefore the rail in these spans may be deeper than those in other spans.
- “Manual Operation” – the mechanism that engages or disengages the interlock device is operated by pulling on a rope or chain connected to the operating mechanism. Alignment of crane to spur rail is judged by visual observation.

Interlock Overview

Interlocks allow a crane to mechanically connect to one or more spur rails, to a crossover rail section between parallel runways, or directly from one crane to another on parallel runways. Loads may then be transferred directly from crane to spur rail, or crane to crane, without re-handling the load.

Interlocks are factory mounted into monorail and crane bridges, and are shipped complete. Attention to field alignment and adjustment procedures (similar to typical crane and monorail alignment and adjustments) will provide years of trouble free operation.

For more information, please see the Crane Interlocks section of the TC/American Crane Systems Catalog.

Before beginning the installation:

- When shipment is received, remove all shipping materials and visually inspect all parts for damage. Repair and/or replace if necessary.
- Check packing lists against materials received and identify all parts.
- Gather all TC/American Crane drawings, plus any vendor equipment drawings, and keep in a secure location for reference during installation and start-up, and to give to end user for future reference.
- See the TC/American MCrane Systems Catalog and drawings provided with the shipment for details, part number information and electrical schematics.
- Store all equipment in a clean, secure area prior to installation.

Installing Cranes and Spur Rails in an Interlocking System:

- Check layout drawings for any notes.
- TC/American crane interlocks mounted in crane bridges and monorails are shipped fully assembled.
- Installation of a runway, crane and monorail system with interlocks should begin at the point where a spur rail or crossover section is located and work out from there, adding runway rail and monorail pieces sequentially. For systems with multiple spur rails or crossovers, begin with the groupings and proceed from there. For more information, see *Monorail and Runway Rail Installation Instructions*. If the monorail portion of the system includes switches, see the appropriate *Switch Installation Instructions*. For electrification systems, see the appropriate *Conductor Bar Installation Instructions*. For suspension of the runway and monorail, see *Suspension Installation Instructions*.
- Verify treadline alignment at all interlock locations.

Initial Start-Up:

- After installation of runway, crane and spur rail components, operate all interlocks several times.
- Verify proper alignment at each interlock location.
- Verify proper engagement of each Crane Interlock to a corresponding Connecting Interlock.
- Run hoist carriers or trolleys through the interlocks to check clearances and smooth transition.
- Verify that safety stops on the interlocks properly contact the hoist carrier or trolley to prevent it from falling off when an interlocking rail end is not aligned to a corresponding rail end.

200 Series Interlocks

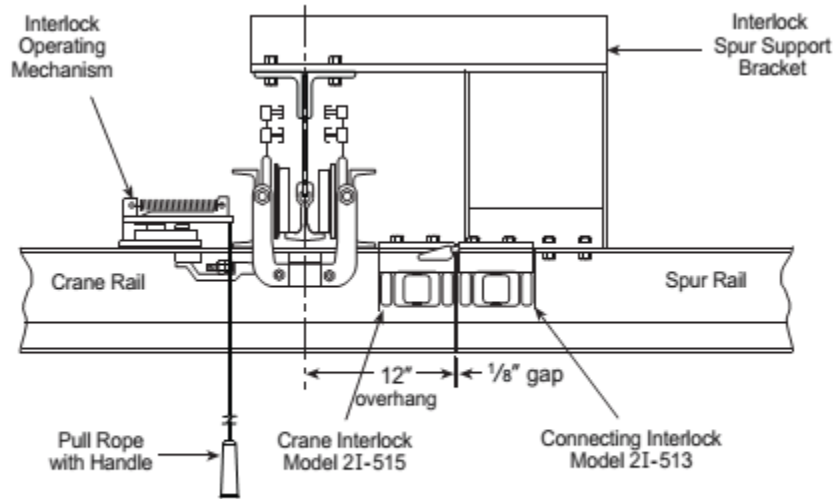

**Interlocking Cranes to Spur Rail
(Typical)**
Non-electrified crane and spur rail shown.

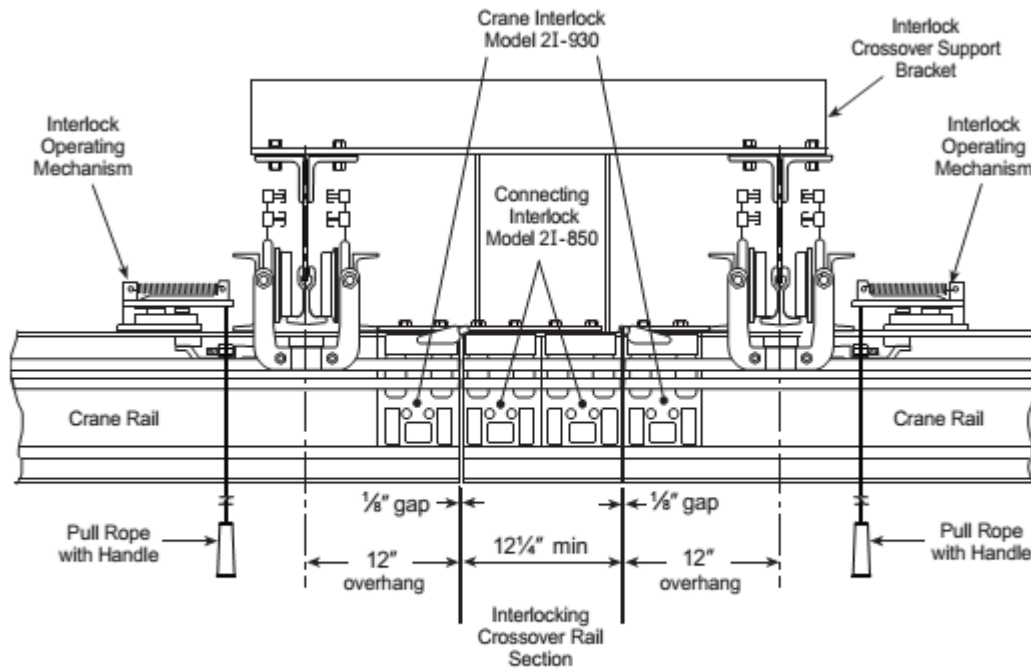

**Interlocking Cranes to Crossover
(Typical)**

200 Series Interlocks

Crane Interlock with Manual Operating Mechanism

Model	Part Number	Figure
2I-515	10-1649-00	Figures 1,3 and 4

For installation in 2GR7-15 or 2GR7-17 rail.
See Step Cut or Notch Note below. See Electrification Note below. See Trolley Note.

2I-930	10-1909-00	Figure 5
--------	------------	----------

For installation in 2GR11-16, 2GR11-23 and 2GR11-26 rail.
See Step Cut or Notch note below. See Electrification Note. See Trolley Note.

Step Cut or Notch Note:

- 2I-515: installed in 7" rail, no step cut required;
- 2I-515: step cut if installed in rail deeper than 7";
- 2I-930: installed in 11" rail, no step cut required;
- 2I-930: step cut if installed in rail deeper than 11".

Electrification Note:

- 2I-515: installed in 7" or deeper rail, bottom contact only;
- 2I-930: installed in 11" or deeper rail, either bottom contact or side contact conductors (minimum 2GR11-26 for side contact).

Trolley Note: 2I-515 and 2I-930 interlocks – use only with trolleys with 4" diameter wheels.

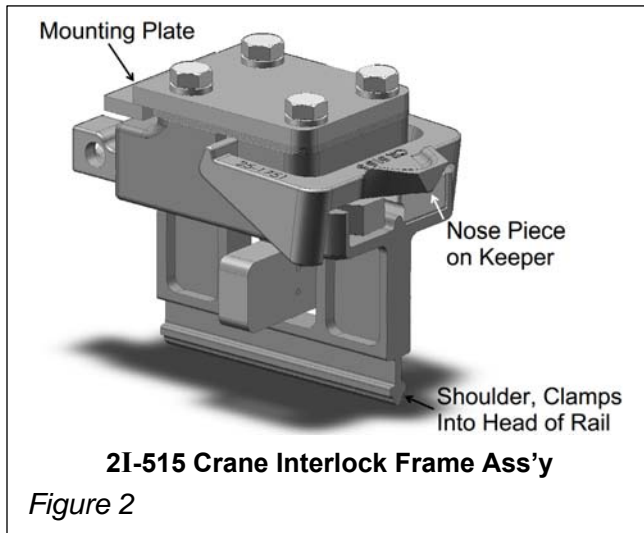
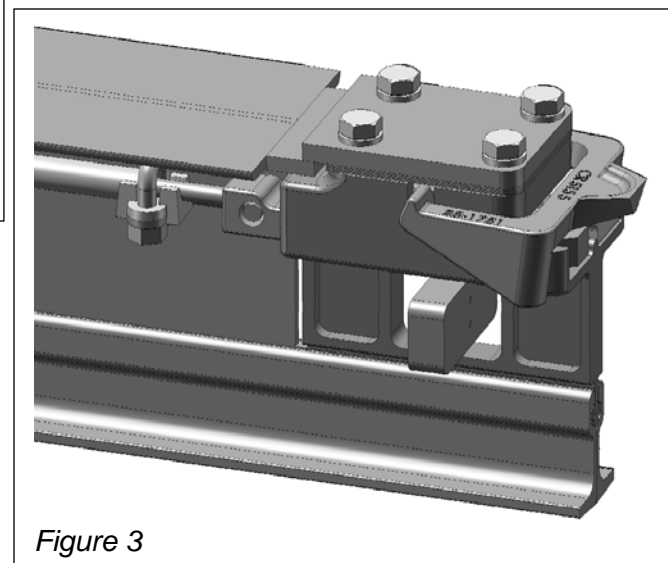
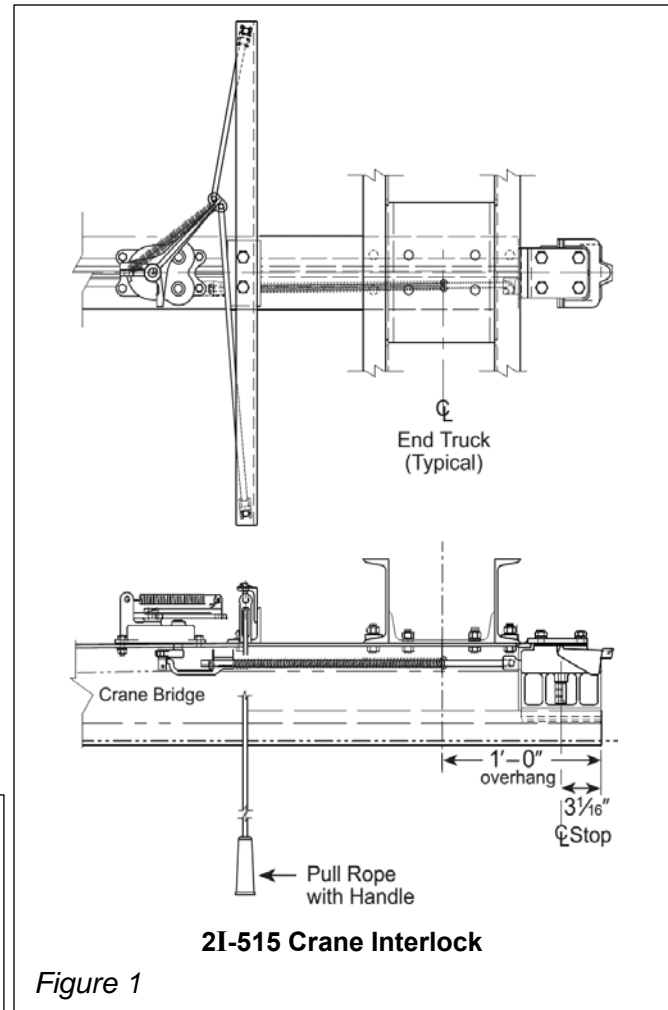

Figure 2: Crane Interlock frame assembly, with mounting plate.

Nose piece of keeper rides over corresponding nose on the connecting interlock to allow the keeper to raise and allow interlock operation.

Figure 3: Interlock mounted in bridge beam. Mounting plate is welded to rail top flange, as shown. (Clamping bolts in 2R3-5T rail not shown).

Butterfly (trolley stop) shown in stop position (not interlocked).



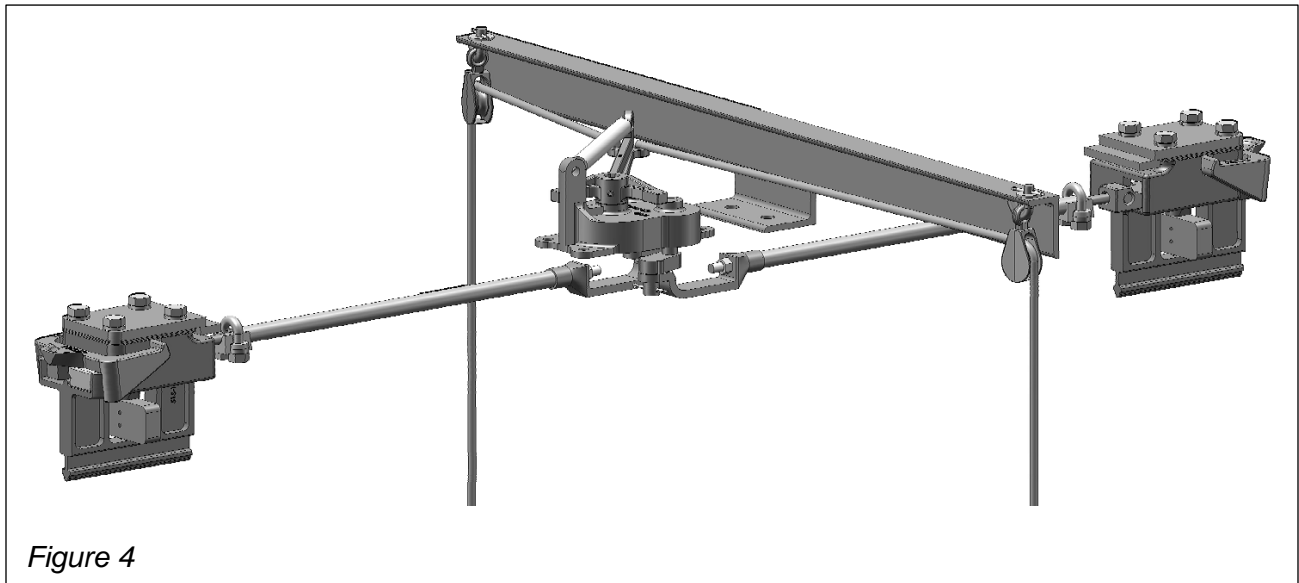

Figure 4

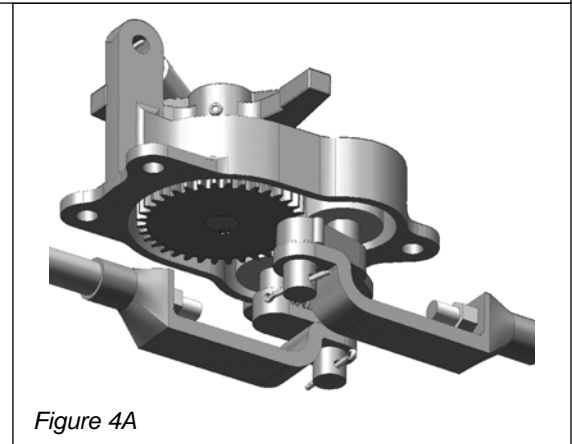
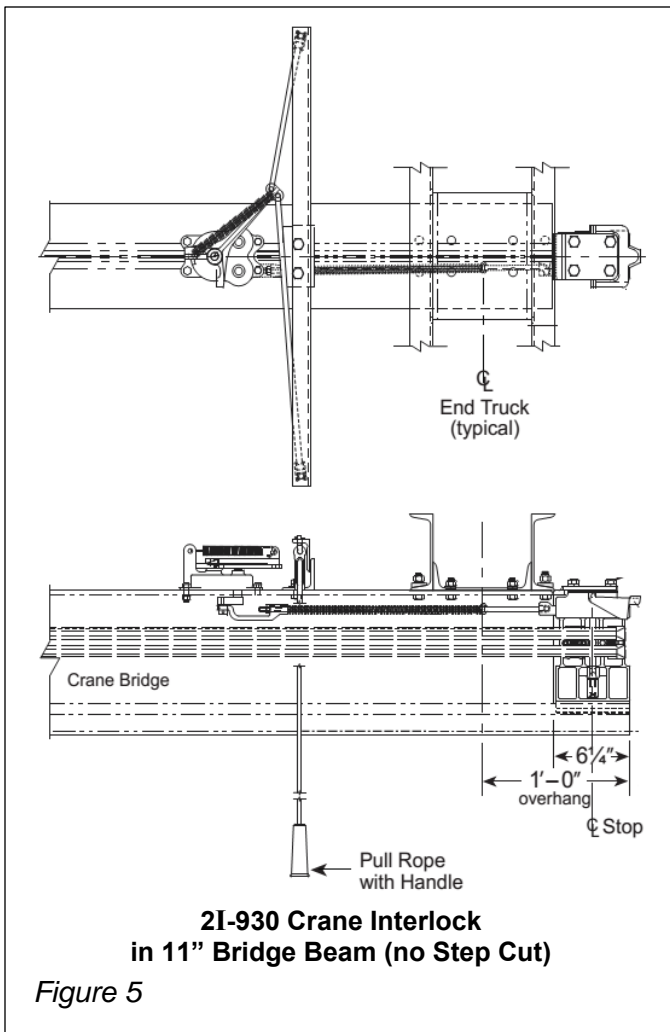

Figure 4A



**2I-930 Crane Interlock
in 11" Bridge Beam (no Step Cut)**

Figure 5

Figure 4: Two 2I-515 Crane Interlocks mounted on a single crane bridge, with one operating mechanism (rail not shown for clarity). Butterflies (trolley stops) shown in stop position (not interlocked).

Butterflies (trolley stops) shown in stop position (not interlocked).

Figure 4A: Detail of Operating Mechanism, configured to operate two interlocks.

NOTE: cranes configured with dual interlocks and one operating mechanism are limited to 22' span and less.

Figure 5: Crane with 11" deep bridge, side contact electrical conductors, and 2I-930 crane interlock.

Crane Interlock Operating Mechanism

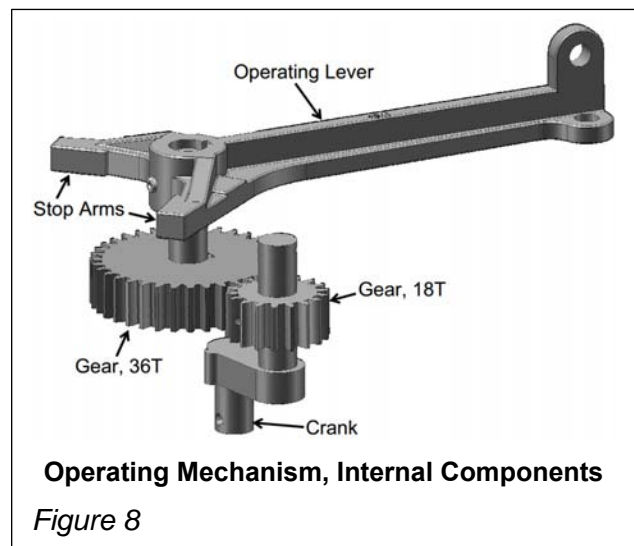
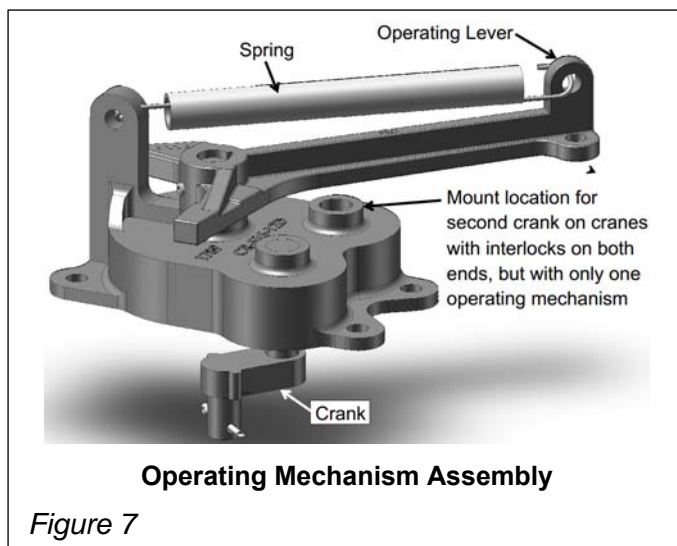
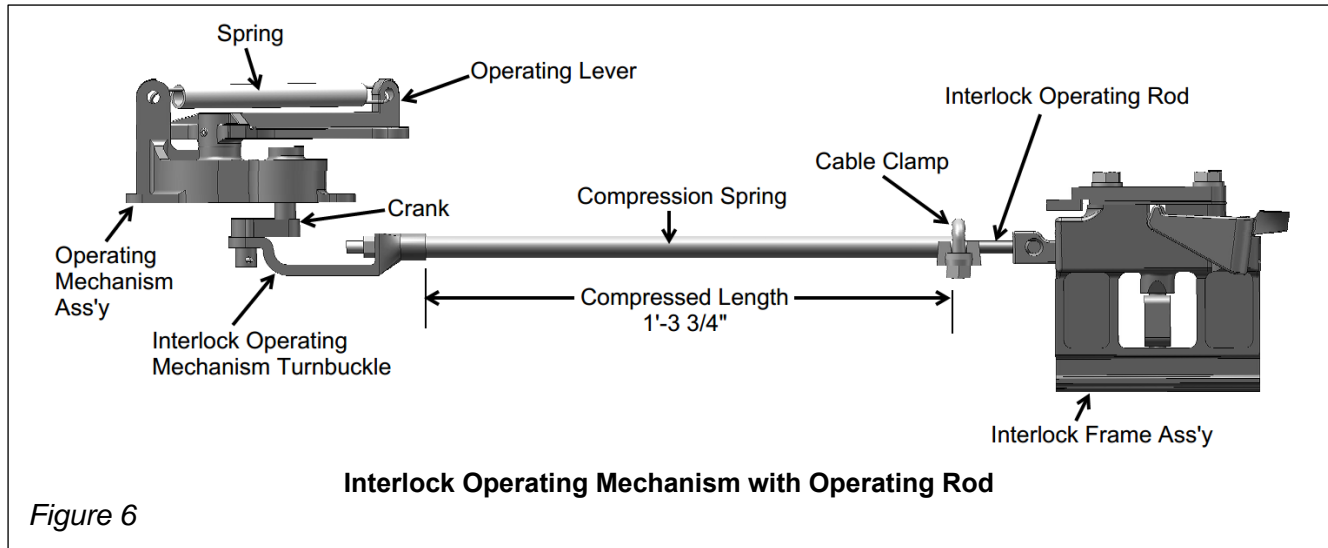

Figure 6: view of typical crane interlock assembly. Shown is 2I-515 Crane Interlock, Operating Mechanism and Interlock Operating Rod for one interlock. Note compression spring length (interlock operating rod is installed inside the compression spring).

Figure 7: details of operating mechanism, lever and crank.

Figure 8: internal details of operating mechanism.

NOTE: Motorized operation not available for these interlocks.

200 Series Interlocks

Connecting Interlock

Model	Part Number	Figure
2I-513	10-1732-00	Figure 9, 10 and 11

For installation in 2GR7-15 or 2GR7-17 rail. See Step Cut or Notch Note below. See Electrification Note below. See Trolley Note.

2I-850	10-1734-00	Figure 12
--------	------------	-----------

For installation in 2GR11-16, 2GR11-23 and 2GR11-26 rail. See Step Cut or Notch note below. See Electrification Note. See Trolley Note.

Step Cut or Notch Note:

- 2I-513: installed in 7" rail, no step cut required;
- 2I-513: step cut if installed in rail deeper than 7";
- 2I-850: installed in 11" rail, no step cut required;
- 2I-850: step cut if installed in rail deeper than 11".

Electrification Note:

- 2I -513: installed in 7" or deeper rail, bottom contact only;
- 2I -850: installed in 11" or deeper rail, either bottom contact or side contact conductors (minimum 2GR11-26 for side contact).

Trolley Note: 2I-513 and 2I-850 connecting interlocks – use only with trolleys with 4" diameter wheels.

Figure 9: 2I -513 Connecting Interlock. Butterfly (trolley stop) shown in "interlock" position (parallel with rail) with interlock bolt extended.

Figure 10: typical example of how a connecting interlock is installed in 2R3-5T rail. Note: clamping bolts in 2R3-5T rail not shown. Butterfly (trolley stop) shown in "interlock" position (parallel with rail).

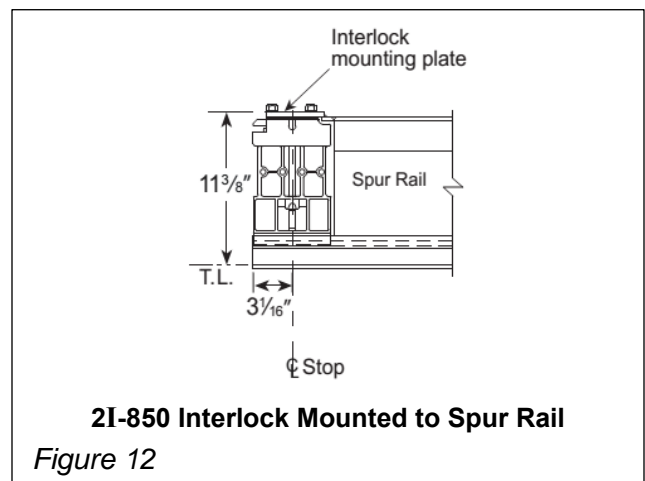
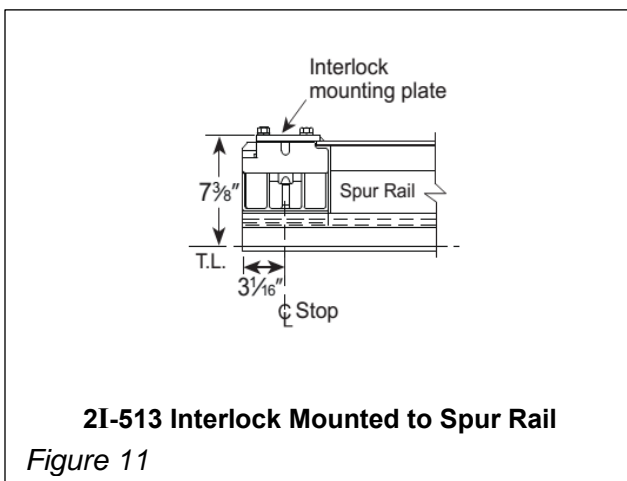
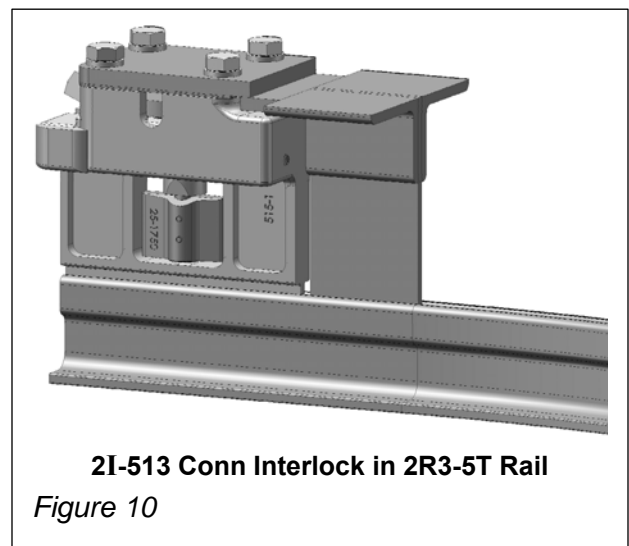
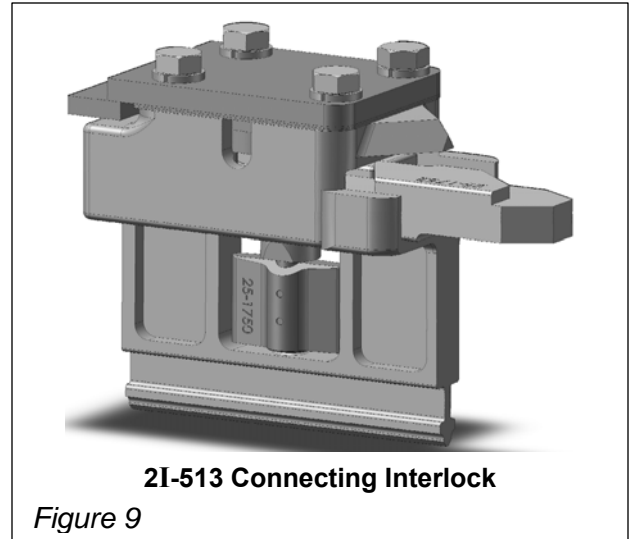

2I-515 Crane Interlock and 2I-513 Connecting Interlock Internal Components and Operation

Figures 13, 14, 15 and 16: Two views each of the internal components of Crane and Connecting Interlocks. Note the relationships of the 2I-515 Interlock and Auxiliary Bolts to the 2I-513 Interlock and Auxiliary Bolts.

When the Crane Interlock Keeper is raised (crane is aligned with a spur rail or another crane with a connecting interlock) and the rope connected to the Operating Mechanism is pulled, the Interlock Bolt of the Crane Interlock extends, contacts the Auxiliary Bolt of the Connecting Interlock and pushes it back. Actuating Pins under the round head of the Interlock Shaft engage either a slot or a lip on the Interlock and Auxiliary Interlock Bolts (see Figures 21, 22 and 23 for more detail).

When the Auxiliary Bolt is pushed back, the Interlock Shaft rotates. This causes the Interlock Bolt of the Connecting Interlock to move forward and push the Auxiliary Bolt of the Crane Interlock, and to rotate that Interlock Shaft. As the Interlock Shafts rotate, the Butterfly (trolley stop) turns from perpendicular to the rail ("stop" position) to parallel with the rail ("interlocked" position).

When the Crane Interlock is fully engaged to the Connecting Interlock, the butterflies are positioned parallel to the rail, and the crane bridge is mechanically connected to the spur rail by the interlock and auxiliary bolts.

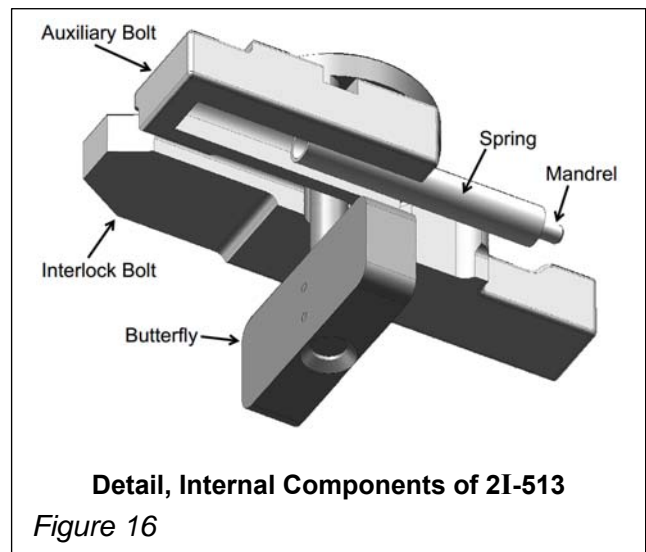
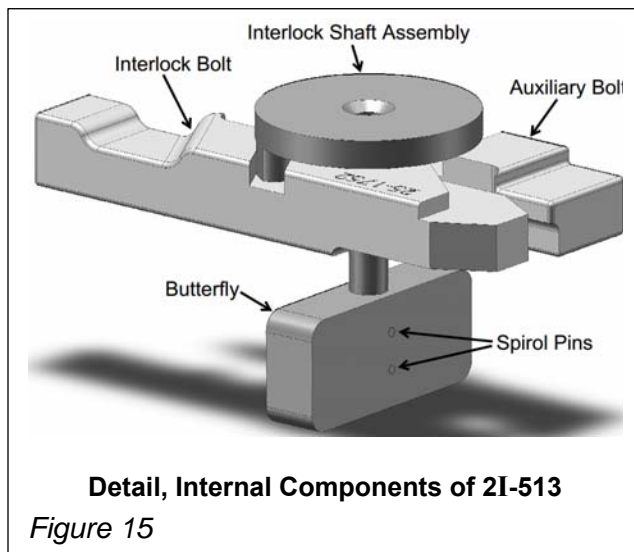
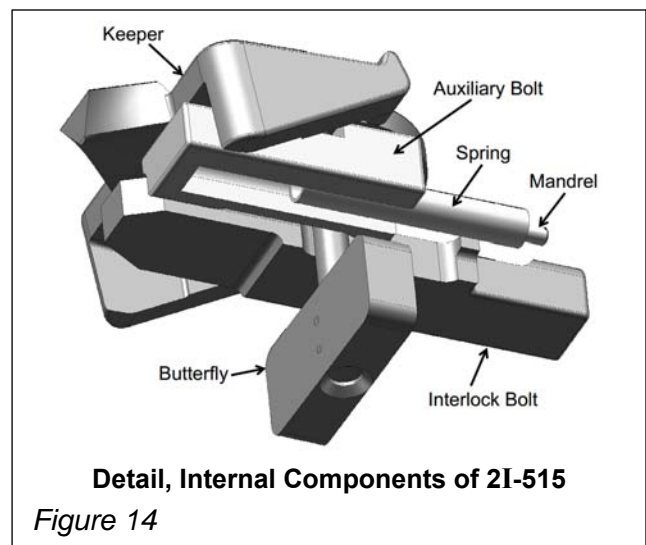
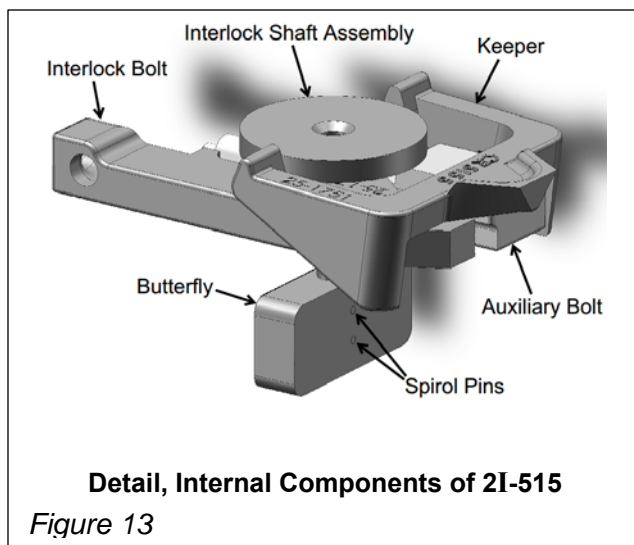

2I-930 Crane Interlock and 2I-850 Connecting Interlock Internal Components and Operation

Figures 17, 18, 19 and 20: Two views each of the internal components of these Crane and Connecting Interlocks.

The function of these components is the same as for the 2I-515 Crane Interlock and 2I-513 Connecting Interlock as described on the previous page. The difference is that the 2I-930 and 2I-850 are designed to be mounted in deeper rail, thus the interlock shaft is longer.

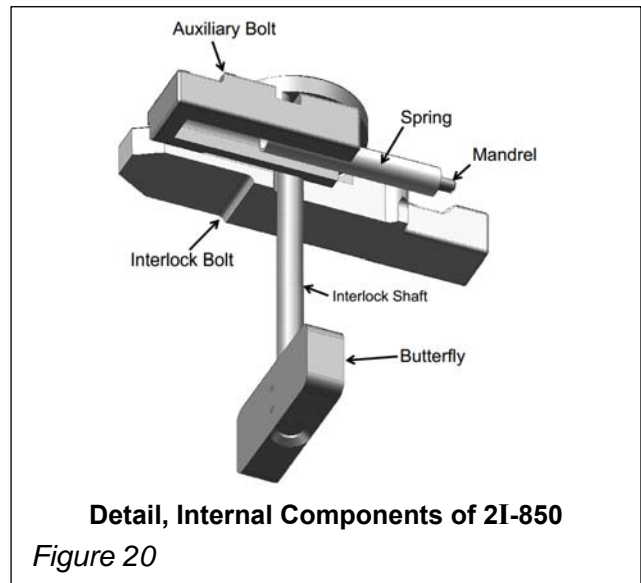
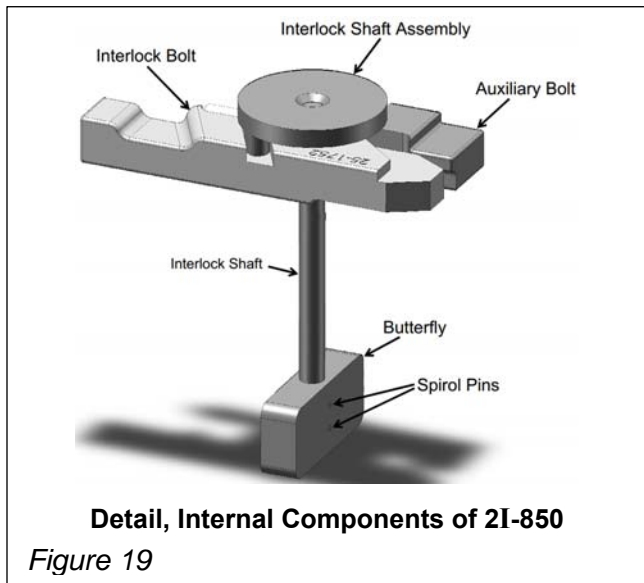
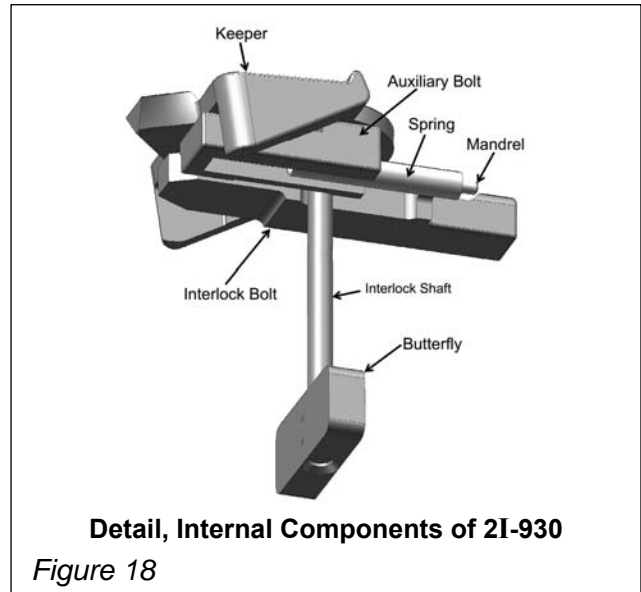
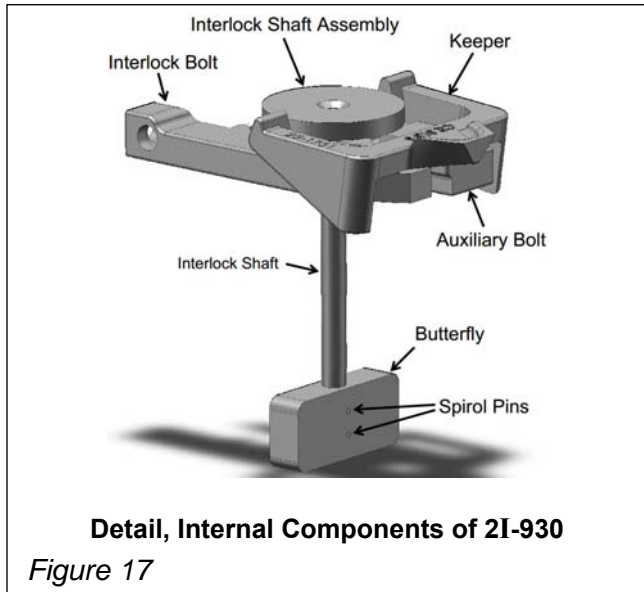

Views of Interlock Bolts, Auxiliary Bolts, and Interlock Shafts

Figure 21: Interlock Bolt and Auxiliary Bolt for 2I-515 or 2I-930 Crane Interlocks

Figure 22: Interlock Bolt and Auxiliary Bolt for 2I-513 or 2I-850 Connecting Interlocks

Figure 23: Interlock Shaft assembly (shown for 2I-515 or 2I-513; shaft is longer for 2I-930 2I-850)

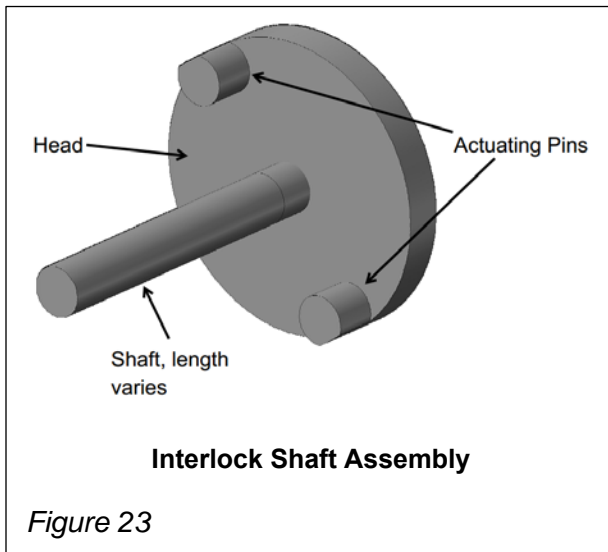
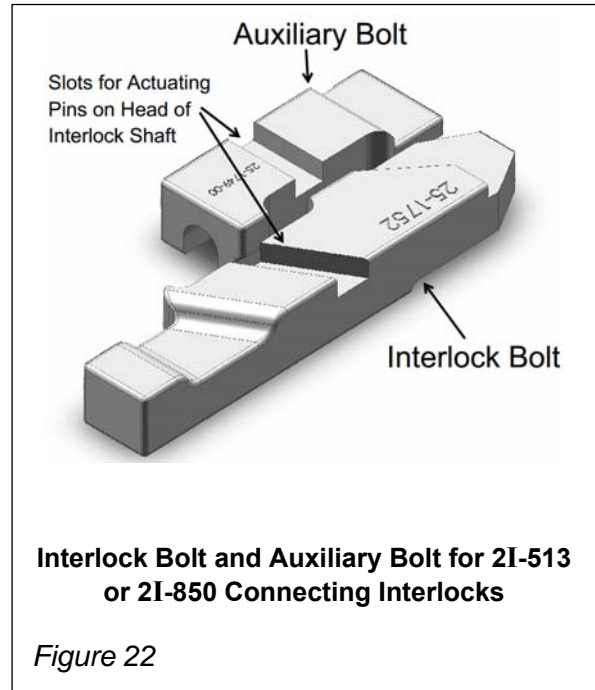
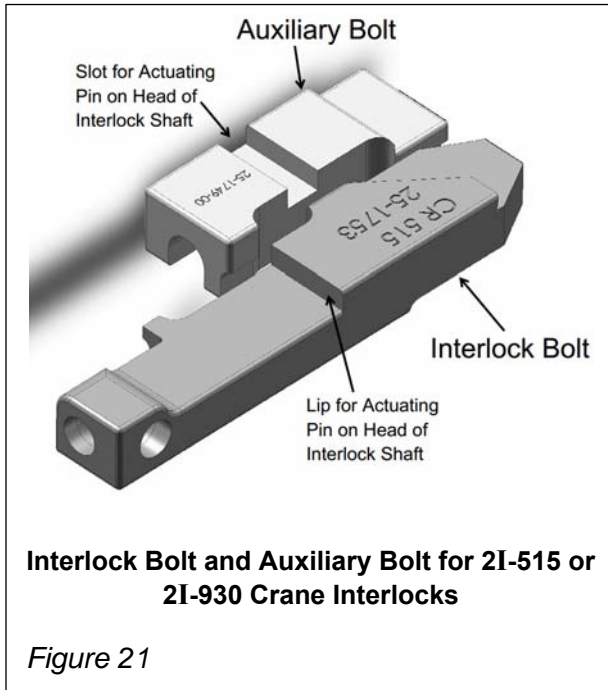

Interlock Operation

For a description of the mechanical operation of the interlock parts, see pages 11, 12 and 13.

Standard shop operation:

- Crane operator personnel move the crane into alignment with a spur rail, crossover section, or adjacent bridge beam. Alignment must be judged visually and will be easier as experience is gained.
- When the crane interlock is aligned to a connecting interlock, the “keeper” on the crane interlock raises to expose the interlock bolt. NOTE: if the crane is just “passing by” a spur rail, crossover or another crane with a connecting interlock, the keeper will still rise up at each passage, but interlocking is not accomplished unless the operating mechanism rope is pulled.
- Pull the rope attached to operating mechanism lever (see Figures 1, 4 and 5).
- Interlocking is completed...transfer the load.
- After assuring the load carrier is clear of the area, pull the other operating mechanism rope to disengage the interlock. Move crane to next assignment.

Optional operation:

- Before the crane is aligned to a connecting interlock, pull the rope of the operating mechanism to “pre-set” the interlock. A spring on the interlock operating rod is compressed which “loads” the interlock.
- Until the crane aligns with a connecting interlock, the keeper prevents the interlock bolt from extending.
- When the crane aligns with a connecting interlock, the keeper raises and the spring pressure is released to make the interlock connection.
- Complete load transfer and disengage of interlock as described in standard operation.
- **CAUTION:** this procedure must be done only at a slow crane travel speed and light loads. High speeds and high loads will cause stress on the interlock components, the crane and the rail.

Interlock Adjustments

Crane and Connecting Interlocks are factory installed and should be properly adjusted as received. However, prior to initial operation and after any maintenance or repair, check the following items and adjust as noted. Before making any adjustments, verify that all parts are installed correctly and are not worn.

A. Treadline to Treadline Alignment

See Page 6 for illustrations of Crane-to-Crossover-to-Crane and Spur Rail-to-Crane Bridge installations.

Gap: adjust crane runway suspension or interlock spur support position to achieve the desired 1/8” gap (3/16” max.) between ends of rail.

Vertical: add or remove shims as required to bring crane and crossover or spur rail treadlines into alignment.

Side-to-Side: the interlock assemblies will control this alignment as they are engaged.

Check alignment at all interlock locations. There may be a slight variation at each point, depending upon manufacturing tolerances of the rail and components. A very light feather grinding may be used to provide a smooth trolley transfer.

Also see a separate document, *Monorail and Runway Rail Installation Instructions*.

B. Interlock Operating Rod

Ref: Figure 6. Position the Operating Mechanism handle so the arm of the Crank is parallel to the rail web and pointed away from the interlock end of the rail, and the stop arm on the operating lever (see Figure 8) is tight against the vertical post of the operating mechanism housing (where the spring is attached).. Loosely assemble the Operating Rod, Spring and Buckle. Hook the end of the Operating Rod into the Interlock Bolt (see Figures 3, 6 and 22) and secure the Buckle to the Crank. Tighten nut on operating rod until the interlock bolt is fully retracted (do not over tighten, all parts must be able to move freely and not be under tension). Slide the Cable Clamp to adjust the compressed length of the Spring as shown. Pull Operating Lever through several throws to verify smooth operation.

Procedure for Interlock Butterfly and Interlock Shaft Replacement

After many years of service, it may be necessary to replace the interlock butterfly. The Butterfly and an Interlock Shaft assembly must be installed as a pair, and the following procedure must be followed for proper positioning.

1. Remove bolts from the top flange mounting plate and loosen the clamping bolts in the head of the 2R3-5T rail (see Figures 24 and 24A).
2. Remove the interlock frame assembly from the crane or spur rail and disassemble to remove the old butterfly and interlock shaft assembly

(Reference Figures 13 thru 20, 24 and 25).

3. Check all parts for condition; clean and/or replace as needed.
4. Position the new butterfly in the frame, insert interlock shaft into the frame and through the hole in the butterfly. Mate the actuating pins of the head of the interlock shaft into the interlock and auxiliary bolts, with the interlock and auxiliary bolts in the stop position (noses of bolts flush with end of rail).
5. Reposition the interlock and auxiliary bolts to align the butterfly parallel to the rail (see Figure 25).
6. Clamp in place and drill butterfly and shaft as shown in Figure 25 for spirol pins. Install pins. Reinstall interlock assembly onto crane or spur rail.
7. For crane interlock, adjust compression spring on interlock operating rod as shown in Figure 6.

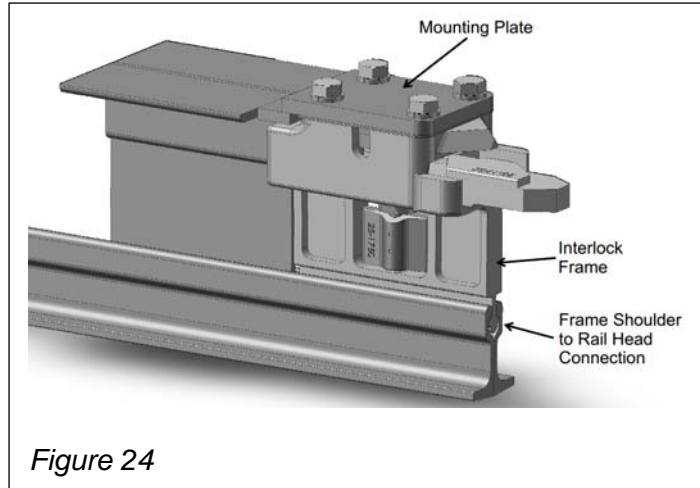

Figure 24

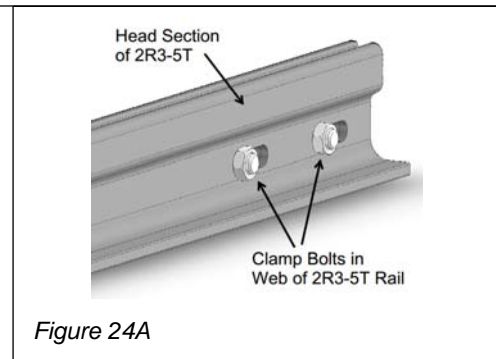

Figure 24A

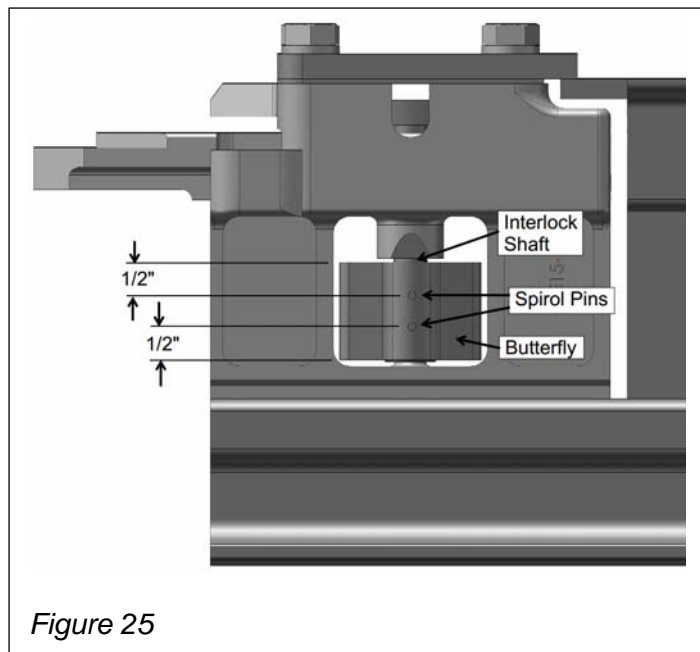

Figure 25

Lubrication

General Lubrication Information

The 2I-513, 2I-515, 2I-930 and 2I-850 interlock assemblies are designed to function with little or no lubrication. Before applying lubricants, consider the crane usage, shop environmental conditions, customer needs or restrictions, etc. Keeping the components clean, but unlubricated, may be the most beneficial. If lubrication is desired, use the following as a guide:

1. Interlock Bolt and Auxiliary Bolt
 - a) maintain the interlock frame, where these bolts slide, clean and clear of dust and dirt. Verify components slide freely (no burrs). Lubricate inside of frame with a lubricant that will not harden under the conditions, or use a dry lubricant such as graphite.
 - b) Slots in Interlock Bolt and Auxiliary Bolts. Lubricate with a lubricant that will not harden under the conditions, or use a dry lubricant such as graphite
2. Interlock Shaft. Light machine oil where shaft extends through the interlock frame casting
3. Operating Mechanism
 - a) light oil where the shaft for the operating lever extends through the housing
 - b) light oil where the interlock crank arm extends through the housing
 - c) the gears within the housing are not accessible for lubrication or inspection without complete disassembly. The gears are not lubricated during factory assembly or installation. If the operating mechanism is removed for any reason, a light coating of a multi-purpose grease or some other lubricant compatible with the customer's facility and operations may be applied.

Lubrication Frequency

Recommended approximately each 6 months for normal operation, more frequently for heavy usage. Each application must be evaluated on its own merits, including: service duty, number of operations per shift, and operating environment.

Maintenance personnel should develop and maintain a record of all monthly inspections. Frequency of lubrication may be adjusted to match operational demands, based upon inspection reports.

Recommended Interlock Lubricants

(for standard industrial operating environments)

Interlock Operating Mechanism	Good grade light oil or multi-purpose lithium grease
Interlock Bolt and Auxiliary Bolt	Good grade multi-purpose lithium grease
Pivot Points	Good grade light machine oil

Note: TC/American Crane does not normally make a "brand name" recommendation for lubricants. Each customer may have a preference based upon many legitimate reasons. TC/A recommends to use a "good quality" lubricant and, when one is chosen, not to mix them.

Adjust lubrication type and frequency based upon the operating environment and customer requirements.

NOTE: before lubricating equipment that will be taken onto a customer's site, check with the customer for any preferences on brands or types (to maintain customer stock uniformity of products used and records maintenance).

NOTE: have Material Safety Data Sheet (MSDS) info available for any lubricants brought onto a work site.

NOTE: verify with customer that lubricants being used will not have an effect upon any production processes.